

## Metal Shower Bracket Assembly

### FEATURES:

- Hand Shower Holder
- Wall mounted metal hand held shower head holder
- Compatible with all Speakman hand held shower heads
- Includes mounting hardware

### STOCK FINISH:



PC BN ORB

### WARRANTY:

Visit [www.speakman.com](http://www.speakman.com) for full product warranty information

- Limited Lifetime Warranty (consumer)
- 1 Year Limited Warranty (commercial)

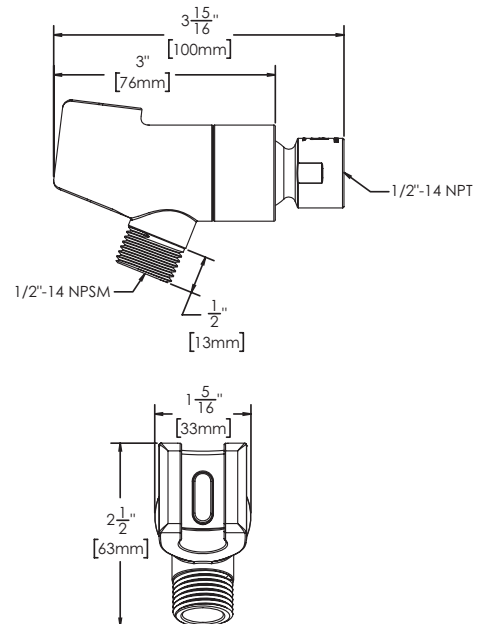
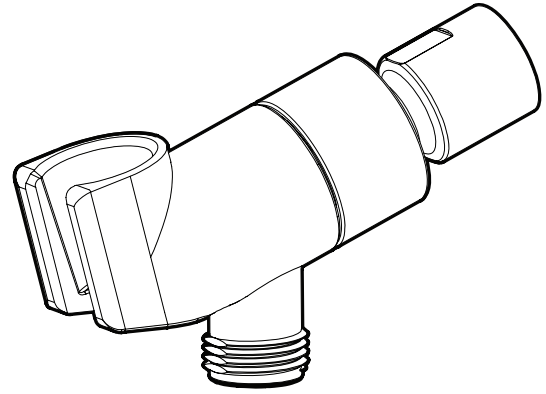

All dimensions are in inches (millimeters) unless otherwise specified and are subject to change without notice.

Architect/Engineer Approval Space:

P: 800-537-2107  
 F: 800-977-2747  
 W: WWW.SPEAKMAN.COM  
 R: 01-SEPTEMBER 2021