

Type \_\_\_\_\_

-09 -74

P4003

**Finish**

Catalog No.	Finish			Dimensions (Inches)			
	Brushed Nickel	Venetian Bronze	Lamping	A	B	C	D
P4003	-09	-74	6 (m) 100w	27-1/4	14-1/4	22-5/8	98

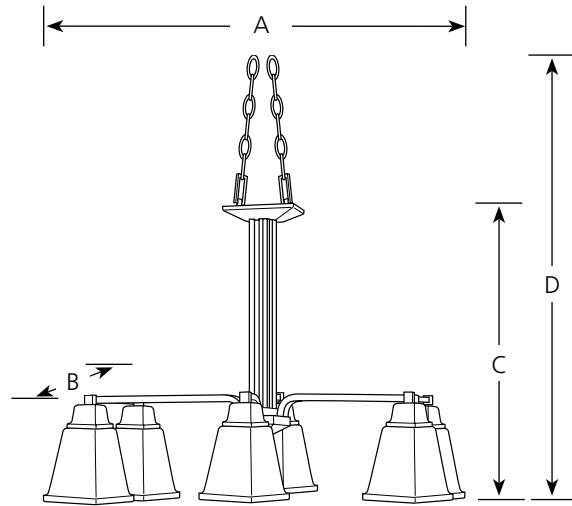

**Specifications:**

General

- This is a linear style chandelier
- Square etched glass shades: 5-1/2" dia. x 5" ht., 1-5/8" center hole
- Twin square arms support shades
- Center column is a cluster of four square rods
- Six feet of 9 gauge matching chain supplied
- Plated Brushed Nickel (-09) or painted Venetian Bronze (-74) finish
- Steel construction
- Companion foyer, chandelier, pendant, close to ceiling, and bath & vanity units

Mounting

- Ceiling chain mounted
- Canopy covers a standard 4" recessed octagonal outlet box
- Canopy is 4-1/4" W x 8" T x 1" deep
- Mounting strap for outlet box included

Electrical

- Medium based ceramic socket
- 15 feet of wired
- Pre-wired

Labeling

- UL-CUL listed