

Type \_\_\_\_\_  
 -31 -38  
 P5204

Catalog No.	Finish		Lamping	Dimensions (Inches)	
	Black	Green		A	B
P5204	-31	-38	1 (m) 100w	6	7

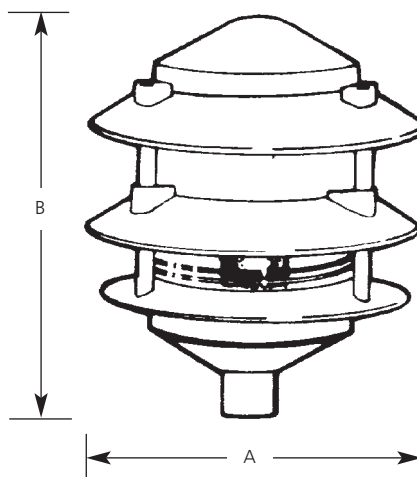

**Specifications:**

General

- Pagoda three tier style
- Clear glass liner: 3-3/8" dia. 5-1/8" ht., 3-1/4" overall width at threads
- Painted Black (-31) or Green (-38) finish
- Aluminum construction

Mounting

- Mounts on landscape post (P8562-31), stake (P5233-31), or approved weatherproof box (order separately)
- 1/2" NPS thread

Electrical

- Medium based ceramic socket.
- 24" long leads
- Pre-wired

Labeling

- UL-CUL wet location listed