

Type \_\_\_\_\_  
 -09 -20  
 P3290

Catalog No.	Finish		Lamping	Dimensions (Inches)	
	Brushed Nickel	Antique Bronze		A	B
P3290	-09	-20	2 (m) 100w	14	7

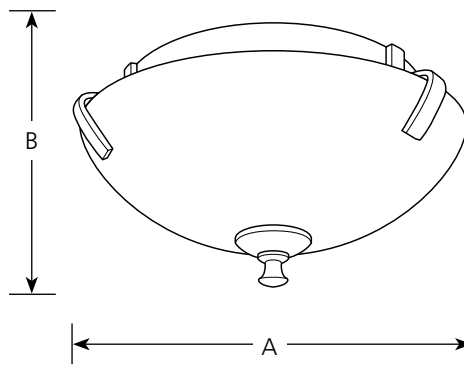

**Specifications:**

General

- Etched glass shade (13" dia., 3-7/8" ht.) with flat steel accents
- Semi-flush style
- Brushed Nickel (-09) is plated
- Antique Bronze (-20) is hand painted
- Steel construction
- Companion chandelier, hall and foyer, wall bracket, close to ceiling, pendant, and bath and vanity units

Mounting

- Ceiling mounted
- Canopy covers a standard 4" hexagonal outlet box
- Mounting strap for outlet box included

Electrical

- Ceramic medium based sockets
- Pre-wired

Labeling

-  US damp location listed



Compact Fluorescent

Wisten CFL

Close-to-Ceiling

Energy Star compliant

Type \_\_\_\_\_  
 -09EBWB -20EBWB  
 P3290

Catalog No.	Finish		Lamping	Dimensions (Inches)	
	Brushed Nickel	Antique Bronze		A	B
P3290	-09EBWB	-20EBWB	2 13w CFL Included	14	7

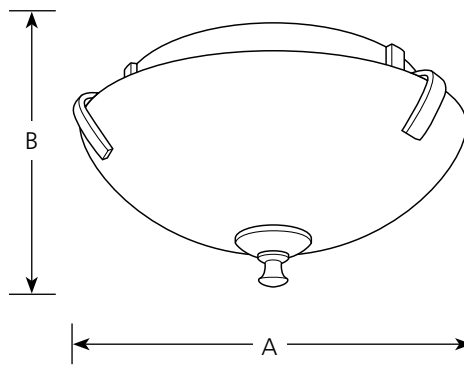

**Specifications:**

General

- Etched glass shade with curved support accents: 13" dia., 3-7/8" ht., 1/2" center hole
- Two 13 watt Compact Fluorescent lamps included
- Semi-flush style
- Brushed Nickel (-09) is plated
- Antique Bronze (-20) is hand painted
- Steel construction
- Energy Star Certified
- Companion chandelier, hall and foyer, wall bracket, close to ceiling, pendant, and bath and vanity units

Mounting

- Ceiling mounted
- Canopy covers a standard 4" hexagonal outlet box
- Canopy is 10" dia. x 1-1/2" ht.
- Mounting strap for outlet box included

Electrical

- GU24 based sockets
- Pre-wired

Labeling

-  US damp location listed



Progress Lighting  
 701 Millennium Blvd.  
 Greenville, South Carolina  
 29607

www.progresslighting.com

Rev. 05/13