

NOTES:

1. TO INSPECT ASSEMBLY, FOLLOW FIRST ARTICLE AND IN PROCESS INSPECTION SHEET.
2. APPLY LOCTITE 680.
3. CUT AND SHORTEN O-RING BY .13" TO .20" IN LENGTH BEFORE INSTALLING.
4. SLIT O-RING BEFORE INSTALLING.
5. APPLY LOCTITE 242.
6. WATER TEST WHOLE UNIT.
7. BAG 5-007 IN A SEPARATE BAG.
8. INSTALLATION TORQUE: 8-14 LB-FT.
9. APPLY LIGHT FILM OF DOW CORNING 111 SILICONE COMPOUND.
10. INSTALLATION TORQUE: 10-14 LB-IN.

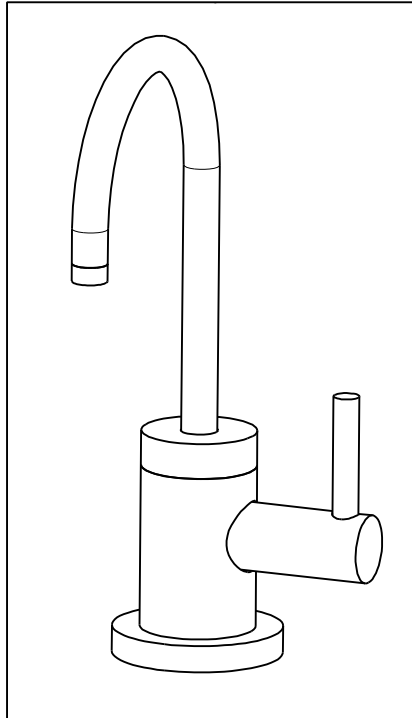

BILL OF MATERIAL (CURRENT LEVEL)

ITEM	PT/ASSY	DESCRIPTION	TYPE	QTY.
1	1-134	CARTR 3/8 HOT 1/4 TR	PART	1
2	5-007	1/4 COMP KIT	ASSEMBLY	1
3	5-052	SPOUT ASM	ASSEMBLY	1
4	10514	MOUNTING CRESCENT	PART	1
5	10516	MOUNTING NUT	PART	1
6	10661	MOUNTING STUD	PART	1
7	10831	ESCUTCHEON (DECK SPOUT)	PART	1
8	11833	ADAPTER	PART	1
9	12657	WATER DISP HANDLE (CONT.)	PART	1
10	50714	WATER DISP. CAR.T HOLDER	PART	1
11	50715	WATER DISP BODY (CONT.)	PART	1
12	50716	WATER DISP BODY CAP (CONT.)	PART	1
13	50717	WATER DISP SPOUT RETAINER	PART	1
14	50721	WATER DISP LEVER (CONT.)	PART	1
15	50760	NIPPLE WATER DISP	PART	1
16	91017	O-RING, #2- 012, EPDM, 65-75 DURO, NSF 61	PART	2
17	91023	O-RING, #2- 019, EPDM, 65-75 DURO, NSF 61	PART	1
18	91063	MOUNTING CRESCENT GASKET	PART	1
19	91382	O-RING, #2- 012, TEFLON,	PART	1
20	91383	O-RING, #2- 014, TEFLON, NSF 61	PART	1
21	91424	WSHR, .81 ID X .93 OD X .045 THK, FLT, PLST	PART	1
22	91753	O-RING, # 2-136, EP, 50 DURO - GREY	PART	1
23	92000	SCREW 8 - 32 X 1/8 SS	PART	1
24	92192	SCRW, 10-32 X 5/8 SKT HD CUP PT SS	PART	1
25	92477	SCRW, M4 X 16 SKT FLT HD SS	PART	1

-	K	EN-4300jj	07/22/21	R.S.
-	J	EN-3941	08/28/19	C.G.
-	H	EN-3311	05/11/17	J.A
-	G	EN-2601	09/16/13	-
-	F	EN-2528	05/08/13	-
-	E	EN-1300	10/26/09	-
-	D	EN-1146	11/17/08	-
-	C	EO-0936	01/29/08	-
-	B	EO-0478	02/16/05	-
-	A	EO-0461	12/14/04	-
-	-	EO-0441	11/19/04	-
ZONE	REV	DESCRIPTION	DATE	APPROVED

COPYRIGHT 2005 BRASSTECH, INC. THESE DRAWINGS AND THE DESIGNS DEPICTED HEREIN ARE THE PROPRIETARY PROPERTY OF BRASSTECH. ANY USE OR REPRODUCTION IS SUBJECT TO THE EXPRESS APPROVAL OF BRASSTECH. UNAUTHORIZED USE IS STRICTLY PROHIBITED. ALL RIGHTS RESERVED.

TESTING	-	-	-
ASSEMBLY	-	-	-
PLATING	-	-	-
POLISHING	-	NEXT ASSY	USED ON
MACHINING	-	APPLICATION	
TOOLING FIXTURE #		REMOVE ALL BURRS AND SHARP EDGES	

UNITS ARE: INCHES [MM]
TOLERANCES ARE:
FRACTIONS DECIMALS ANGLES
±1/16" .X ±.1 [2.5] ±1°
.XX ±.06 [1.5]

(X.XXX) DENOTES CRITICAL DIMS.
ALL THREADS ARE CRITICAL

DRAWN	JINSON	07/22/21
CHECKED	R.S.	07/22/21
APPROVED	R.S.	07/22/21

BRASSTECH 2001 CARNEGIE AVE.
INCORPORATED SANTA ANA, CA 92705
(949) 417-5207

COLD WATER DISP COMP

DWG NO.	106C	REV	K
SCALE	.375	REF.	-
SHEET	1	OF	3

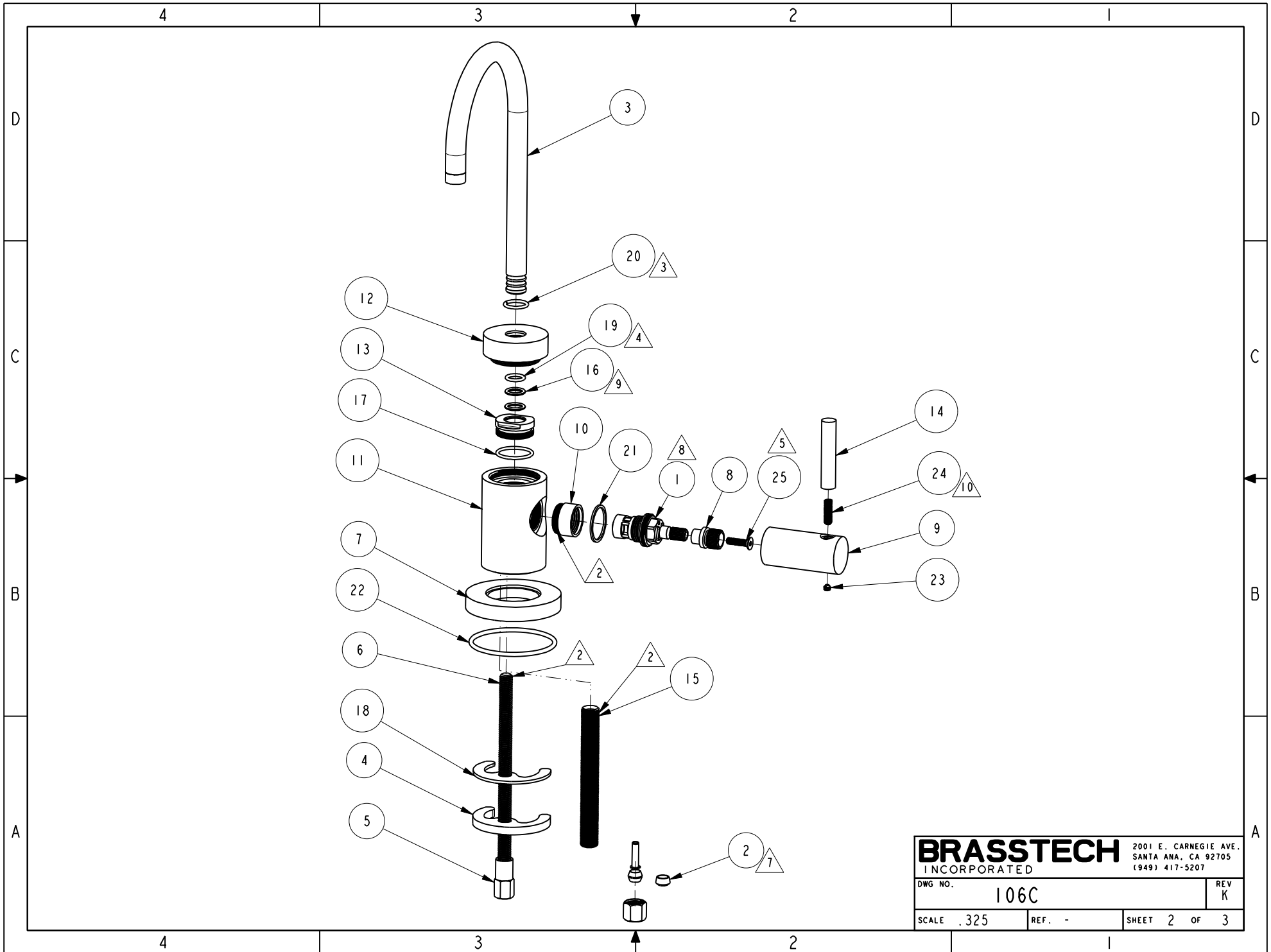

BRASSTECH		2001 E. CARNEGIE AVE. SANTA ANA, CA 92705 (949) 417-5207	
DWG NO.	106C	REV	K
SCALE	.325	REF.	-
		SHEET	2 OF 3

