

4

3

2

1

D

D

C

C

B

B

A

A

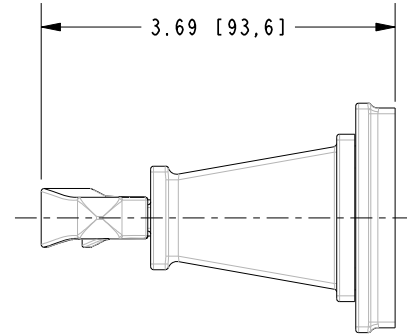
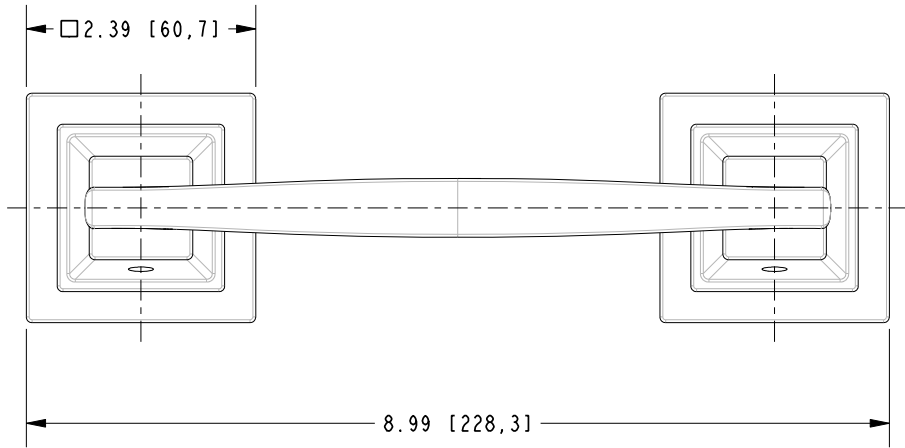
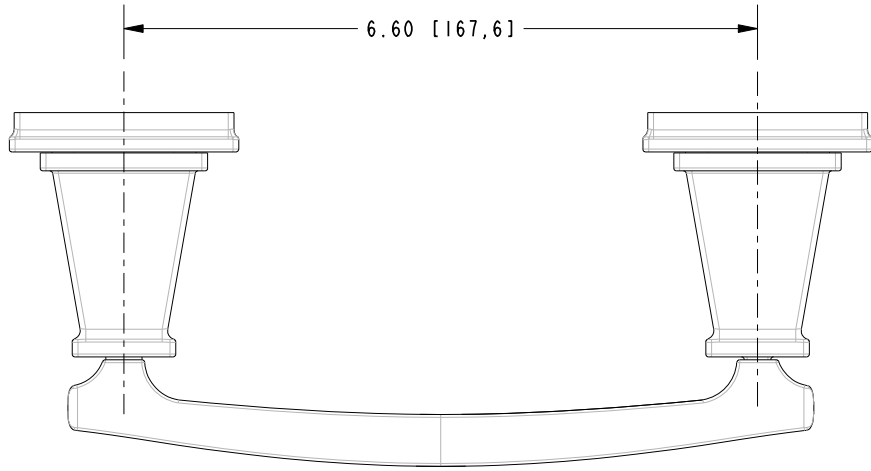

BRASSTECH		2001 E. CARNEGIE AVE.	
INCORPORATED		SANTA ANA, CA 92705	
		(949) 417-5207	
DWG NO.	43-28	REV	A
SCALE	.500	REF.	-
		SHEET	2 OF 2