

4

3

2

1

BILL OF MATERIAL (CURRENT LEVEL)

ITEM	PT/ASSY	DESCRIPTION	TYPE	QTY.
1	3-887	3-887 TRIM KIT - R/T W/HNDSHWR	ASSEMBLY	1
2	1-507	R/T 3-VALVE/QUICK CONNECT	ASSEMBLY	1

D

D

C

C

B

B

A

A

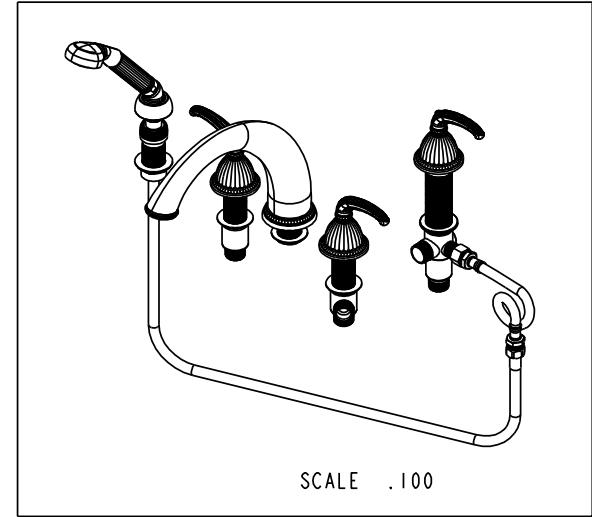
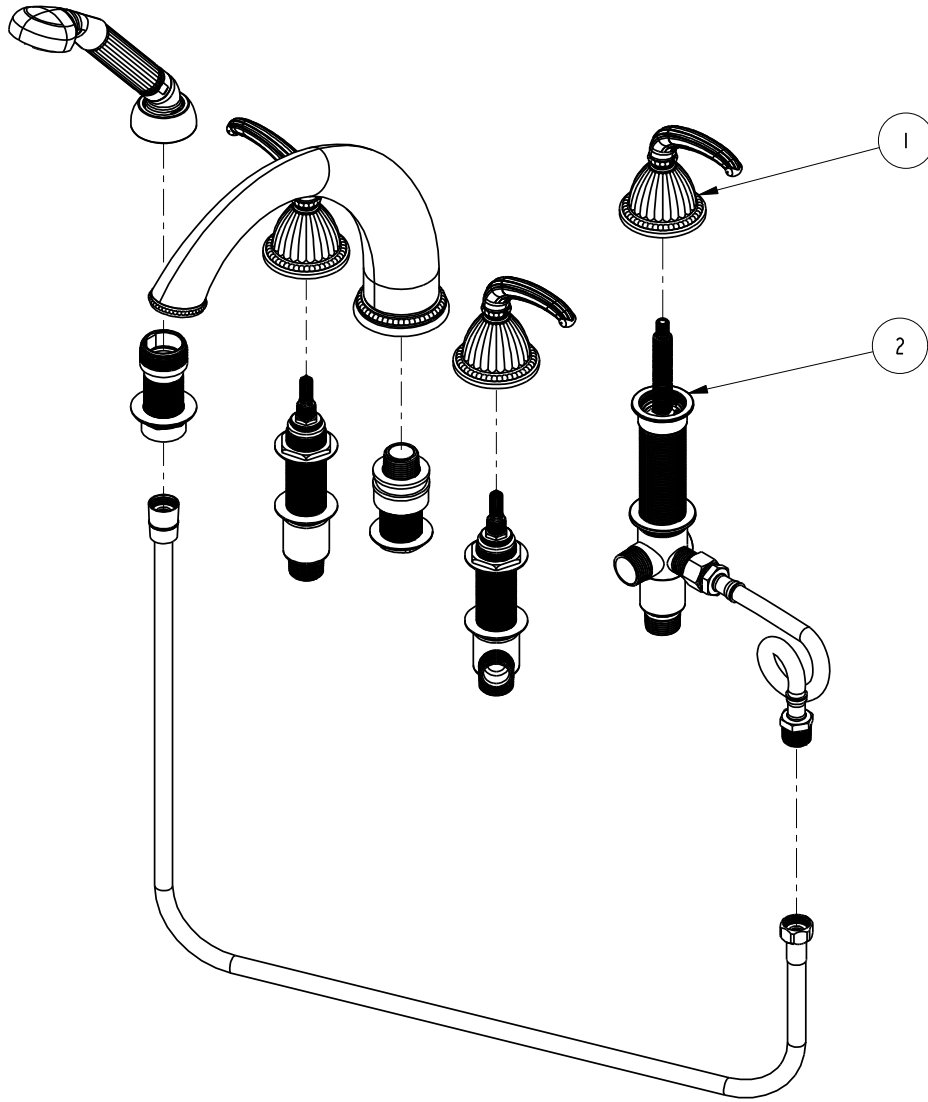

COPYRIGHT 2005 BRASSTECH, INC. THESE DRAWINGS AND THE DESIGNS DEPICTED HEREIN ARE THE PROPRIETARY PROPERTY OF BRASSTECH. ANY USE OR REPRODUCTION IS SUBJECT TO THE EXPRESS APPROVAL OF BRASSTECH. UNAUTHORIZED USE IS STRICTLY PROHIBITED. ALL RIGHTS RESERVED.

BRASSTECH
INCORPORATED

2001 E. CARNEGIE AVE.
SANTA ANA, CA 92705
(949) 417-5207

ROMAN TUB WITH HANDSHOWER

ASSY. NO.	887		
SCALE	REF.	SHEET	OF
.175	-	1	3
REV	REV	DESC	DATE
B	EN-1257	05/29/09	
A	EO-0904	10/30/07	

4

3

2

1

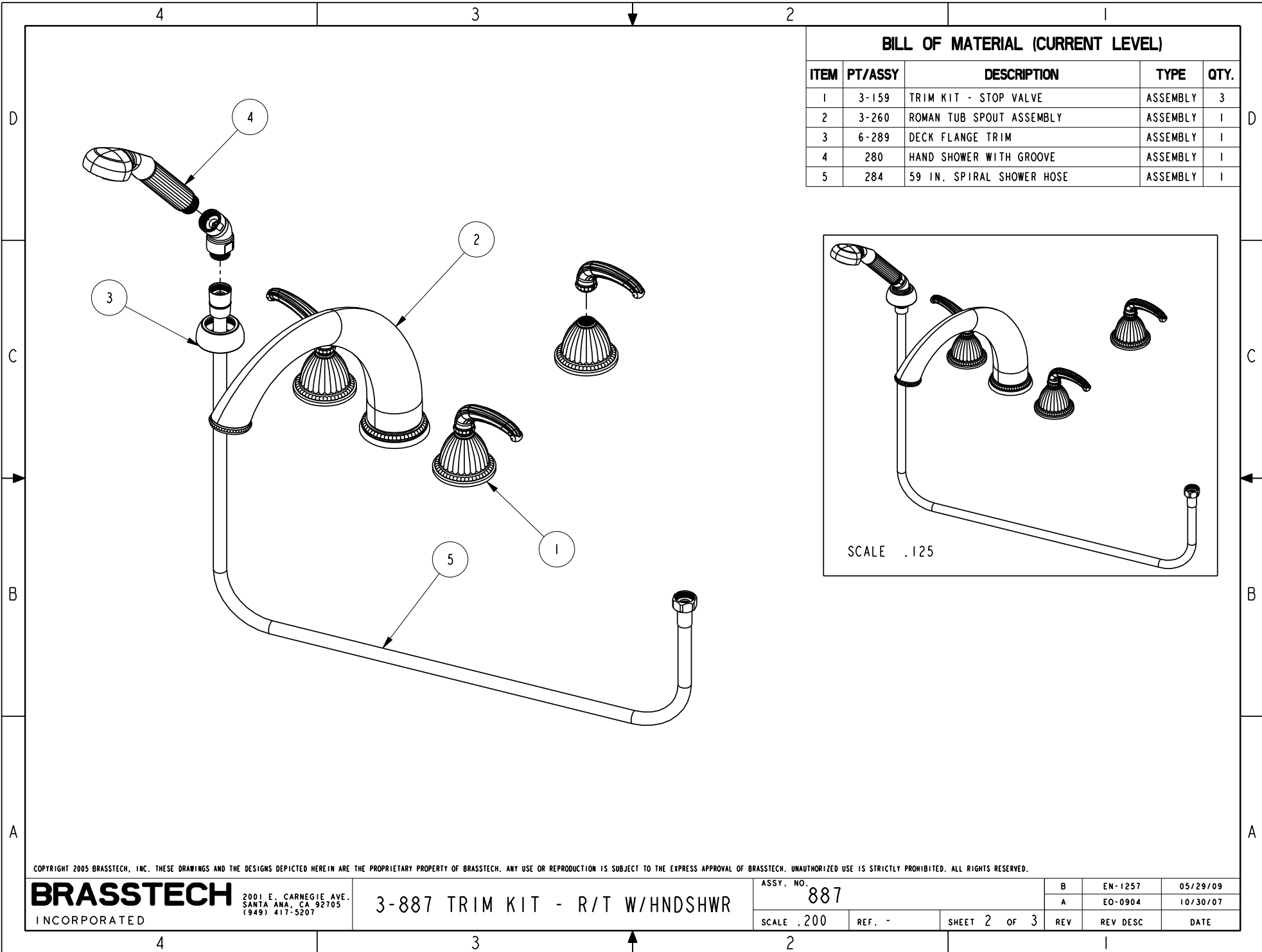

BILL OF MATERIAL (CURRENT LEVEL)

ITEM	PT/ASSY	DESCRIPTION	TYPE	QTY.
1	3-159	TRIM KIT - STOP VALVE	ASSEMBLY	3
2	3-260	ROMAN TUB SPOUT ASSEMBLY	ASSEMBLY	1
3	6-289	DECK FLANGE TRIM	ASSEMBLY	1
4	280	HAND SHOWER WITH GROOVE	ASSEMBLY	1
5	284	59 IN. SPIRAL SHOWER HOSE	ASSEMBLY	1

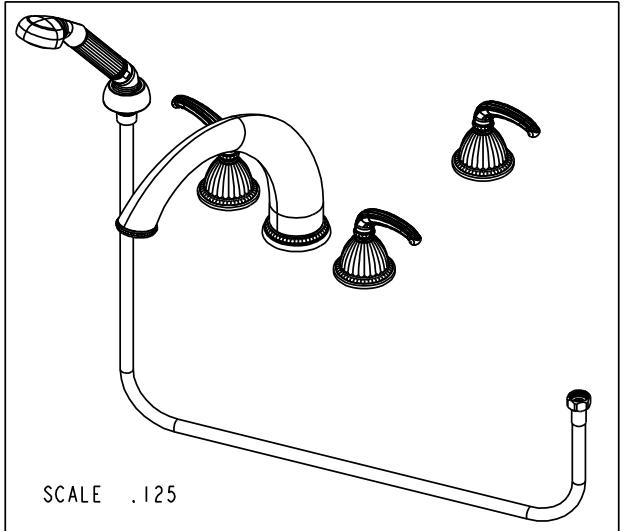

COPYRIGHT 2005 BRASSTECH, INC. THESE DRAWINGS AND THE DESIGNS DEPICTED HEREIN ARE THE PROPRIETARY PROPERTY OF BRASSTECH. ANY USE OR REPRODUCTION IS SUBJECT TO THE EXPRESS APPROVAL OF BRASSTECH. UNAUTHORIZED USE IS STRICTLY PROHIBITED. ALL RIGHTS RESERVED.

BRASSTECH
INCORPORATED
2001 E. CARNEGIE AVE.
SANTA ANA, CA 92705
(949) 417-5207

3-887 TRIM KIT - R/T W/HNDSHWR

ASSY. NO.	887		
SCALE	REF.	SHEET	REV
.200	-	2 OF 3	REV
			REV DESC
			DATE

B	EN-1257	05/29/09
A	EO-0904	10/30/07

SPECIFICATION DWG

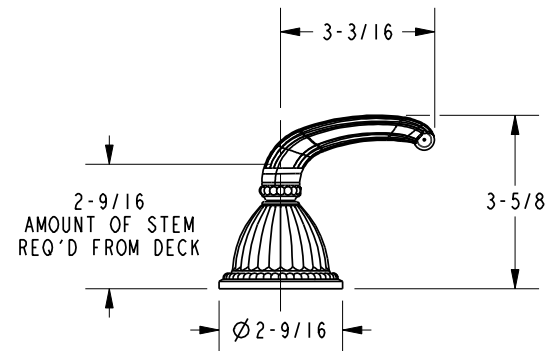
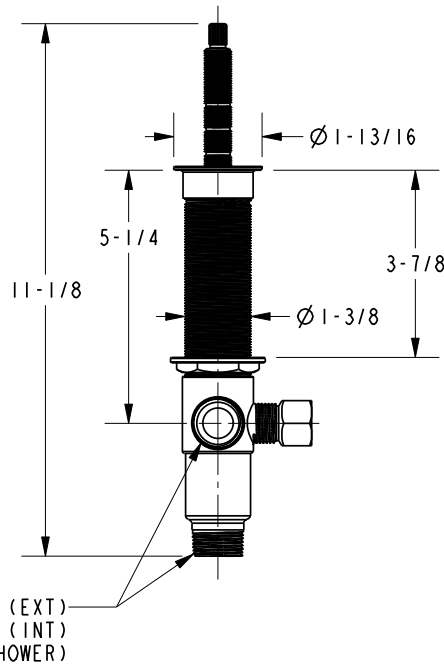
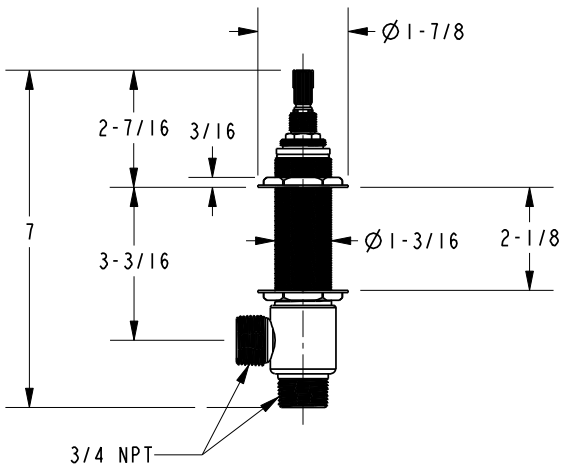
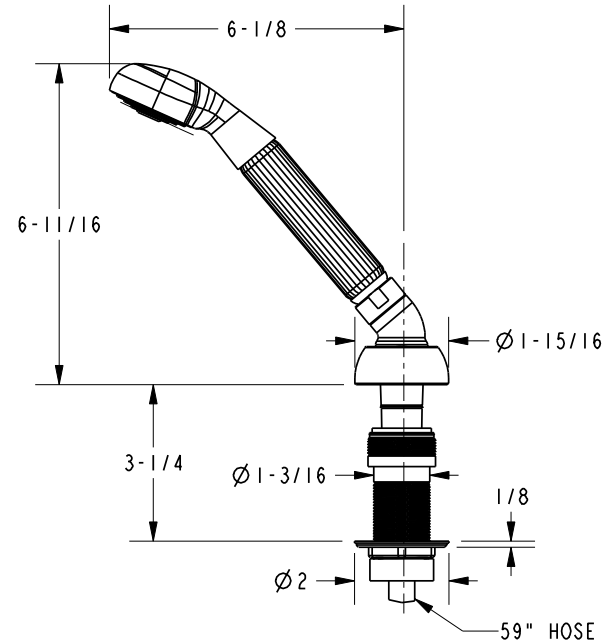
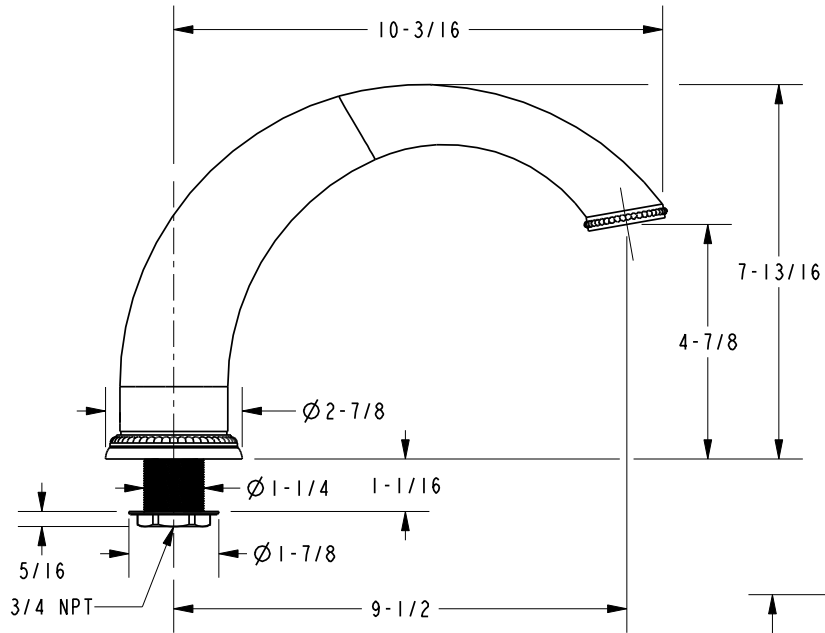

DIMENSIONS ARE IN INCHES AND AN APPROXIMATION OF A TYPICAL INSTALLATION

COPYRIGHT 2005 BRASSTECH, INC. THESE DRAWINGS AND THE DESIGNS DEPICTED HEREIN ARE THE PROPRIETARY PROPERTY OF BRASSTECH. ANY USE OR REPRODUCTION IS SUBJECT TO THE EXPRESS APPROVAL OF BRASSTECH. UNAUTHORIZED USE IS STRICTLY PROHIBITED. ALL RIGHTS RESERVED.

BRASSTECH		2001 E. CARNEGIE AVE. SANTA ANA, CA 92705 (949) 417-5207	
DWG NO.	887	REV	B
SCALE	.250	REF.	-
		SHEET	3 OF 3