

NOTES:

(NI) 1. FIT / FORM / FUNCTION SHALL FOLLOW PS-E.008.

BILL OF MATERIAL (CURRENT LEVEL)

ITEM	PT/ASSY	DESCRIPTION	TYPE	QTY.
1	2-990	TUB AND SHOWER PLATE ASM	ASSEMBLY	1
2	2-989	COLLAR ASM	ASSEMBLY	1
3	91308	TEMP LIMIT STOP - THERMO	PART	1
4	12344	HANDLE BONNET	PART	1
5	12345	SLEEVE - THERMO	PART	1
6	2-991	THERMO BONNET ASM	ASSEMBLY	1
7	92113	SCRW, M4 X .7 X 40 PHL FLT HD SS	PART	2
8	2-147	870 HANDLE	ASSEMBLY	2

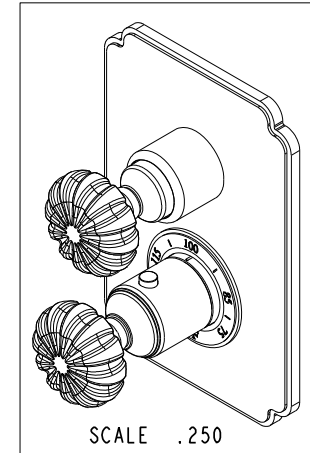
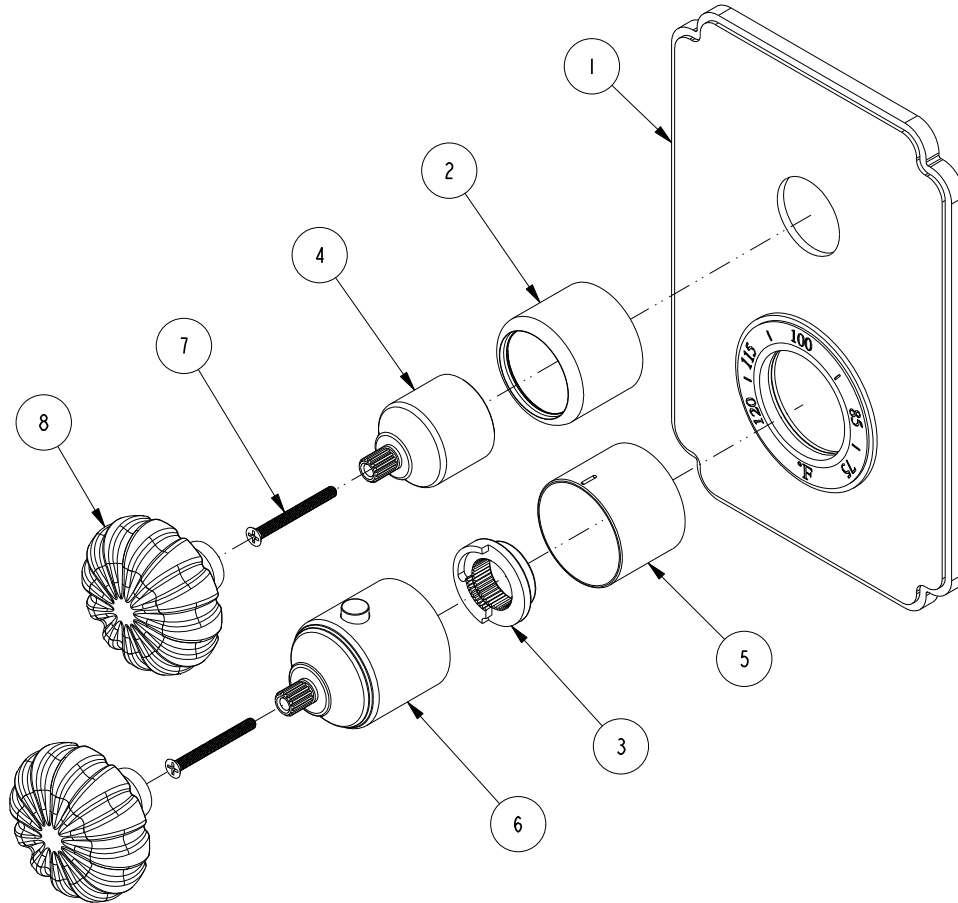

ZONE	REV	DESCRIPTION	DATE	APPROVED
-	A	EN-3236	01/17/17	J.M.
-	-	EN-2775h	11/20/15	J.M.

COPYRIGHT 2005 BRASSTECH, INC. THESE DRAWINGS AND THE DESIGNS DEPICTED HEREIN ARE THE PROPRIETARY PROPERTY OF BRASSTECH. ANY USE OR REPRODUCTION IS SUBJECT TO THE EXPRESS APPROVAL OF BRASSTECH. UNAUTHORIZED USE IS STRICTLY PROHIBITED. ALL RIGHTS RESERVED.

TESTING	ASSEMBLY	PLATING	POLISHING	MACHINING	TOOLING	FIXTURE #	APPLICATION
-	-	-	-	-	-	-	REMOVE ALL BURRS AND SHARP EDGES
-	-	-	-	-	-	-	REMOVE ALL BURRS AND SHARP EDGES

UNITS ARE: INCHES [MM]
 TOLERANCES ARE:
 FRACTIONS DECIMALS ANGLES
 $\pm 1/16"$.X $\pm .1$ [2.5] $\pm 1^\circ$
 .XX $\pm .06$ [1.5]
 (X.XXX) DENOTES CRITICAL DIMS.
 ALL THREADS ARE CRITICAL

DRAWN JINSON 01/17/17
 CHECKED RAVINDRA 01/17/17
 APPROVED R.S. 01/17/17

BRASSTECH 2001 CARNEGIE AVE.
 INCORPORATED SANTA ANA, CA 92705
 (949) 417-5207

THERMO TUB / SHOWER

DWG NO. **3-873TS** REV A

SCALE .375 REF. - SHEET 1 OF 2

