

NOTES:

(N1) 1. FIT / FORM / FUNCTION SHALL FOLLOW PS-E.008.

BILL OF MATERIAL (CURRENT LEVEL)

ITEM	PT/ASSY	DESCRIPTION	TYPE	QTY.
1	3-234	WALL TUB SPOUT ASM	ASSEMBLY	1
2	3-575	HANDLE AND ESCUTCHEON ASSEMBLY	ASSEMBLY	2

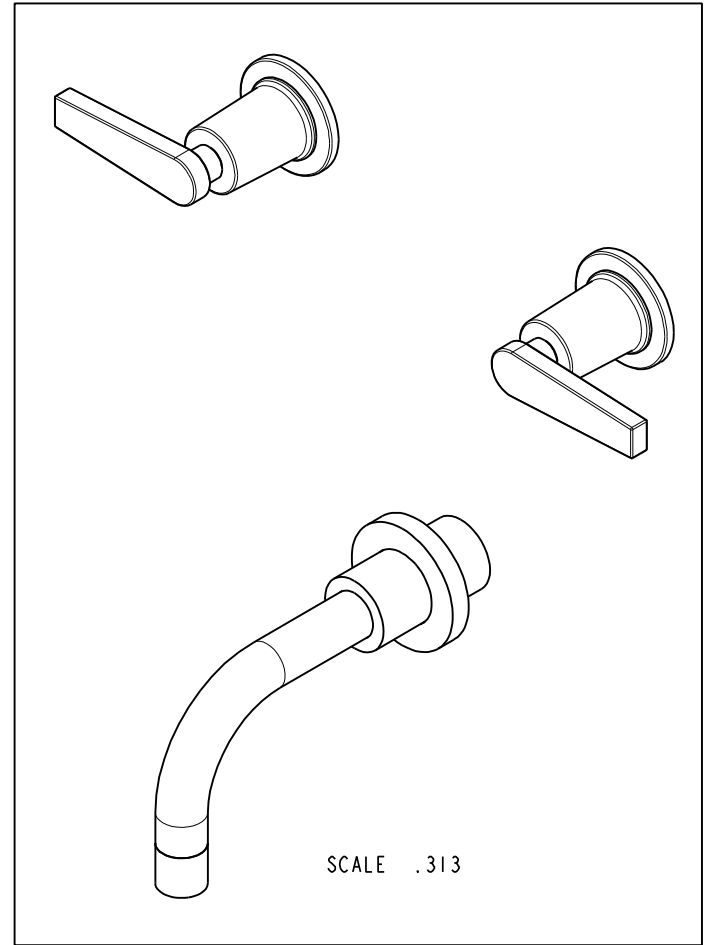
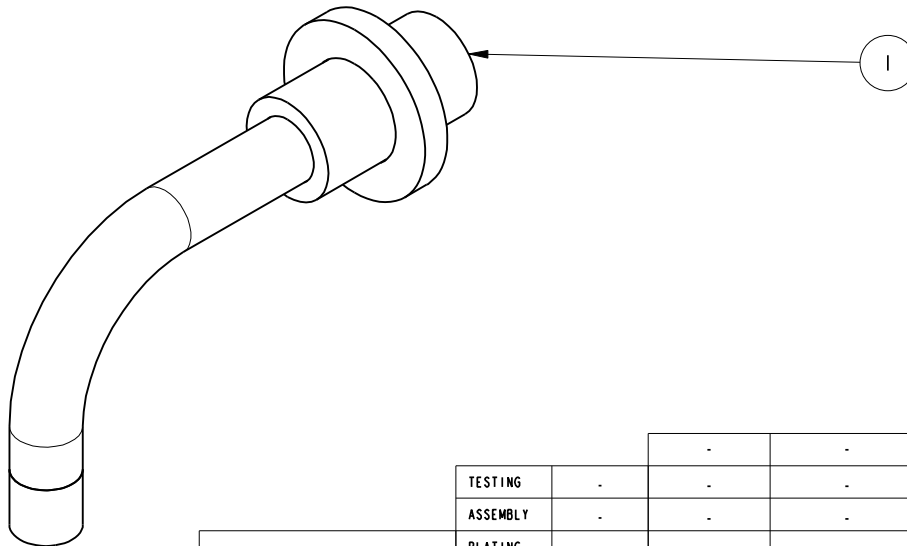
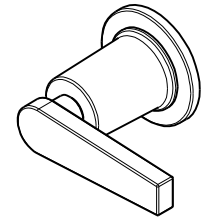
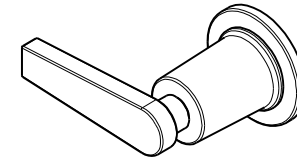
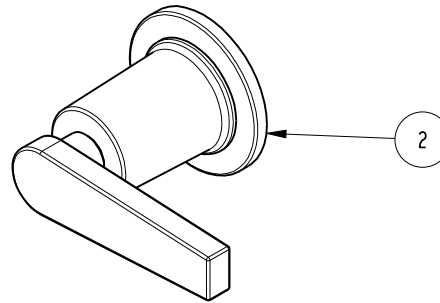
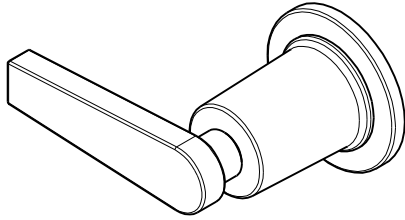

SCALE .313

COPYRIGHT 2005 BRASSTECH, INC.
THESE DRAWINGS AND THE DESIGNS
DEPICTED HEREIN ARE THE PROPRIETARY
PROPERTY OF BRASSTECH. ANY USE
OR REPRODUCTION IS SUBJECT TO
THE EXPRESS APPROVAL OF BRASSTECH.
UNAUTHORIZED USE IS STRICTLY
PROHIBITED. ALL RIGHTS RESERVED.

UNITS ARE: INCHES [MM]
TOLERANCES ARE:
FRACTIONS DECIMALS ANGLES
 $\pm 1/16"$ $.X \pm .1$ [2.5] $\pm 1^\circ$
 $.XX \pm .06$ [1.5]

(X.XXX) DENOTES CRITICAL DIMS.
ALL THREADS ARE CRITICAL

DRAWN JINSON 07/27/16
CHECKED RAVINDRA 07/27/16
APPROVED J.M. 07/27/16

BRASSTECH 2001 CARNEGIE AVE.
INCORPORATED SANTA ANA, CA 92705
(949) 417-5207

WALL MOUNT TUB FAUCET

DWG NO. 3-2975 REV -
SCALE .438 REF. - SHEET 1 OF 3

ZONE	REV	DESCRIPTION	DATE	APPROVED
-	-	EN-3041	07/27/16	J.M.

TESTING	ASSEMBLY	PLATING	POLISHING	MACHINING	TOOLING FIXTURE #	APPLICATION
-	-	-	-	-	-	REMOVE ALL BURRS AND SHARP EDGES
-	-	-	-	-	-	NEXT ASSY USED ON

