

NOTES:

(N1) I. FIT / FORM / FUNCTION SHALL FOLLOW PS-E.008.

BILL OF MATERIAL (CURRENT LEVEL)

ITEM	PT/ASSY	DESCRIPTION	TYPE	QTY.
1	12122	THERMO SHOWER PLATE	PART	1
2	1-331	THERMO WALL PLATE ASM	ASSEMBLY	1
3	2-808	THERMO BONNET W/ CROSS HANDLE	ASSEMBLY	1
4	11029	SLEEVE - THERMO	PART	1
5	91308	TEMP LIMIT STOP - THERMO	PART	1

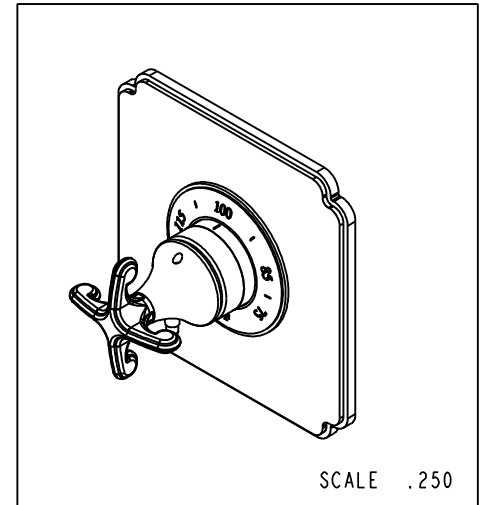
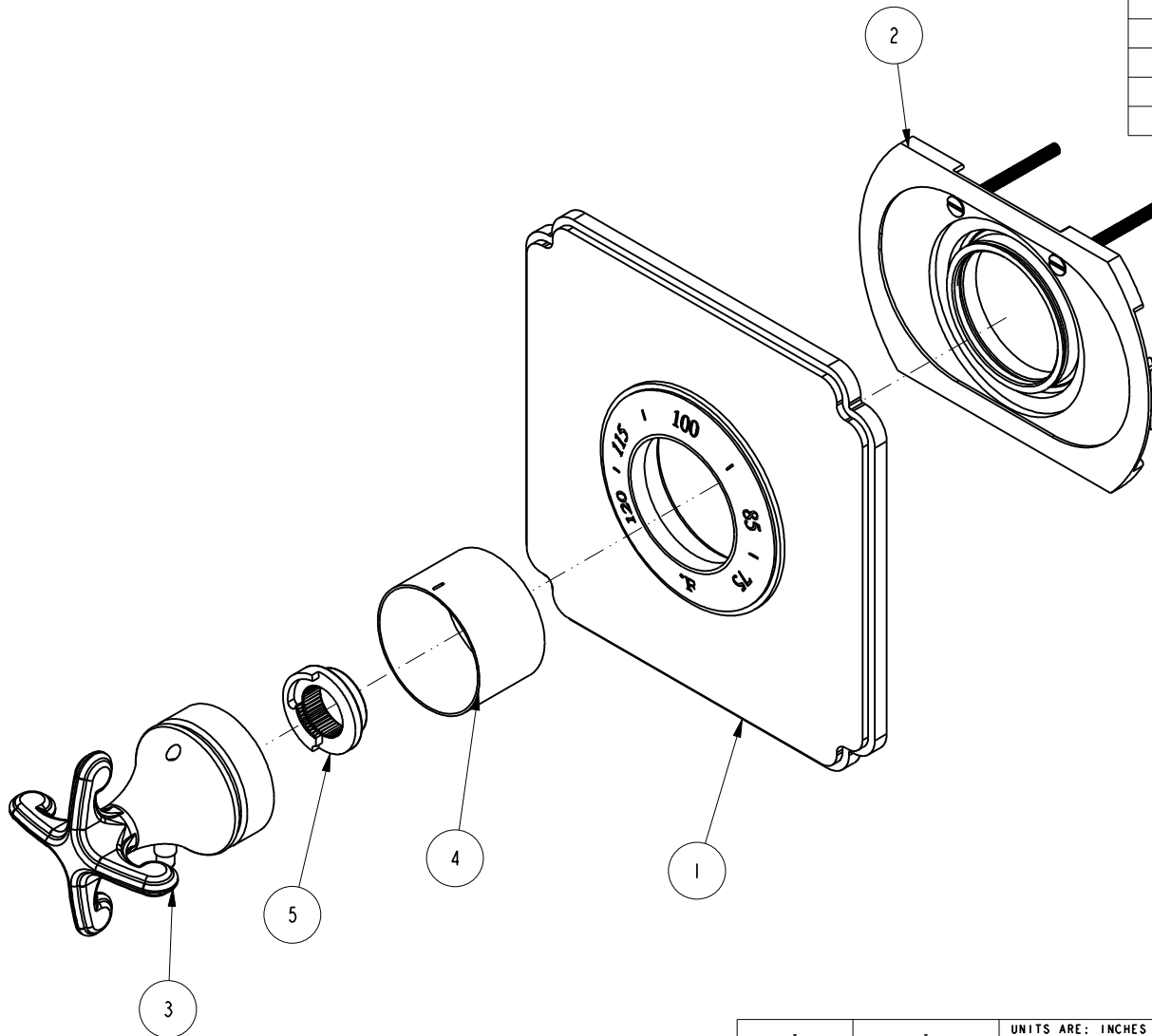

ZONE	REV	DESCRIPTION	DATE	APPROVED
-	C	EN-2161f	02/27/15	J.M
-	B	EN-1735	01/06/12	-
-	A	EN-1735	07/12/11	-
-	-	EN-1735	06/10/11	-

COPYRIGHT 2005 BRASSTECH, INC. THESE DRAWINGS AND THE DESIGNS DEPICTED HEREIN ARE THE PROPRIETARY PROPERTY OF BRASSTECH. ANY USE OR REPRODUCTION IS SUBJECT TO THE EXPRESS APPROVAL OF BRASSTECH. UNAUTHORIZED USE IS STRICTLY PROHIBITED. ALL RIGHTS RESERVED.

TESTING	-	-	-
ASSEMBLY	-	-	-
PLATING	-	-	-
POLISHING	-	NEXT ASSY	USED ON
MACHINING	-	APPLICATION	
TOOLING FIXTURE #	REMOVE ALL BURRS AND SHARP EDGES		

UNITS ARE: INCHES [MM]		TOLERANCES ARE:	
FRACTIONS	DECIMALS	ANGLES	
±1/16"	.X ±.1 [2.5]	±1°	
	.XX ±.06 [1.5]		
(X.XXX) DENOTES CRITICAL DIMS.			
ALL THREADS ARE CRITICAL			
DRAWN	RAVINDRA	02/27/15	
CHECKED	RK PAI	02/27/15	
APPROVED	JINSON	02/27/15	

**BRASSTECH** 2001 CARNEGIE AVE.  
INCORPORATED SANTA ANA, CA 92705  
(949) 417-5207

**THERMOSTATIC TRIM PLATE WITH CROSS HANDLE**

DWG NO. **3-2524TS** REV C

SCALE .400 REF. - SHEET 1 OF 3

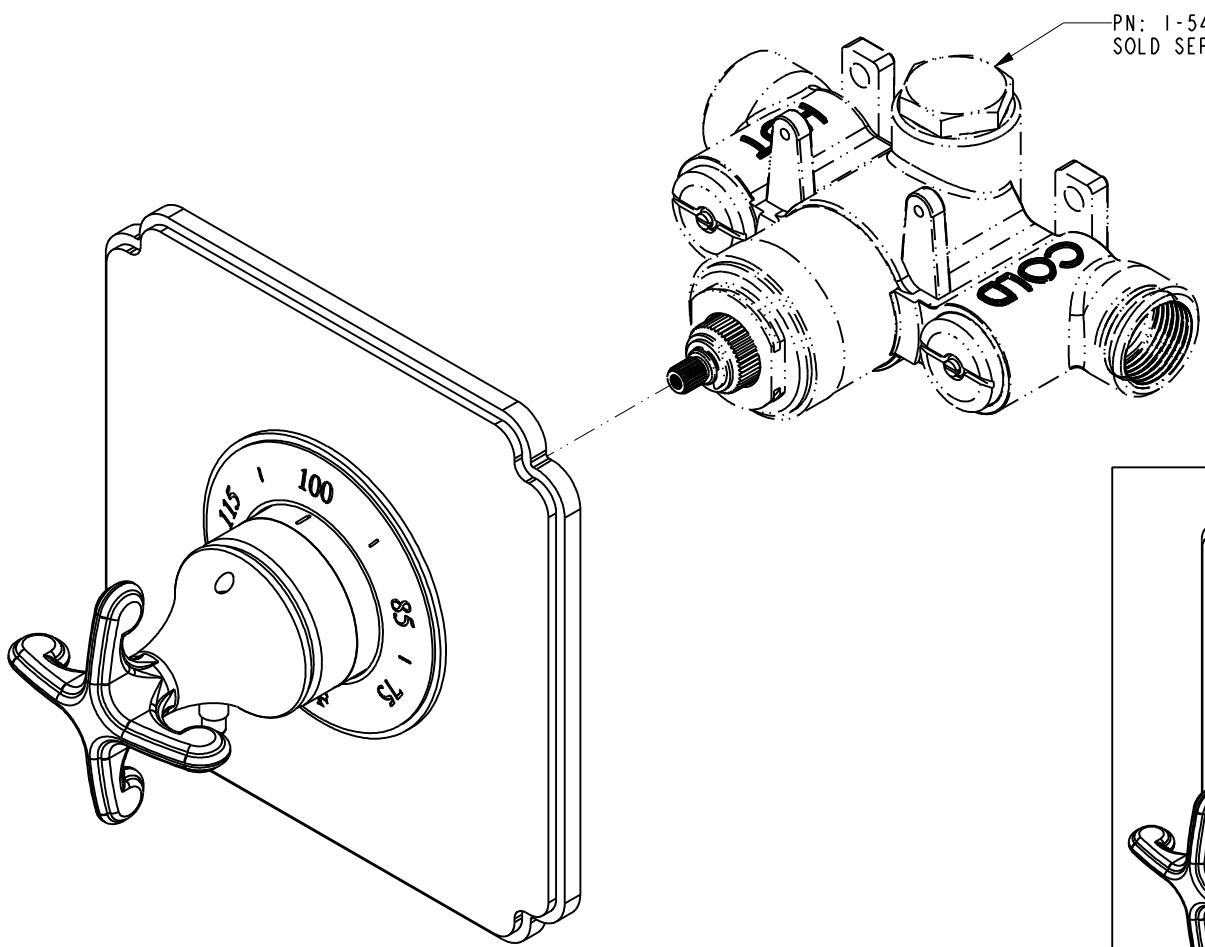

PN: 1-540  
SOLD SEPERATELY

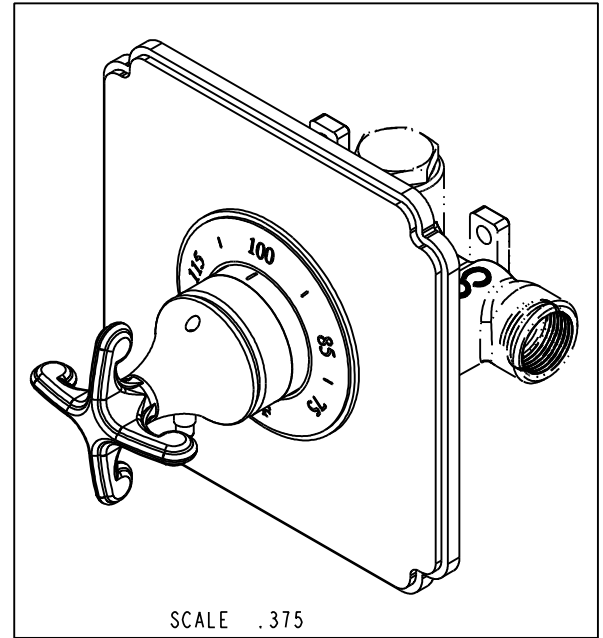

SCALE .375

<b>BRASSTECH</b>		2001 E. CARNEGIE AVE.	
INCORPORATED		SANTA ANA, CA 92705	
		(949) 417-5207	
DWG NO.	3-2524TS		REV C
SCALE .500	REF. -	SHEET 2 OF 3	

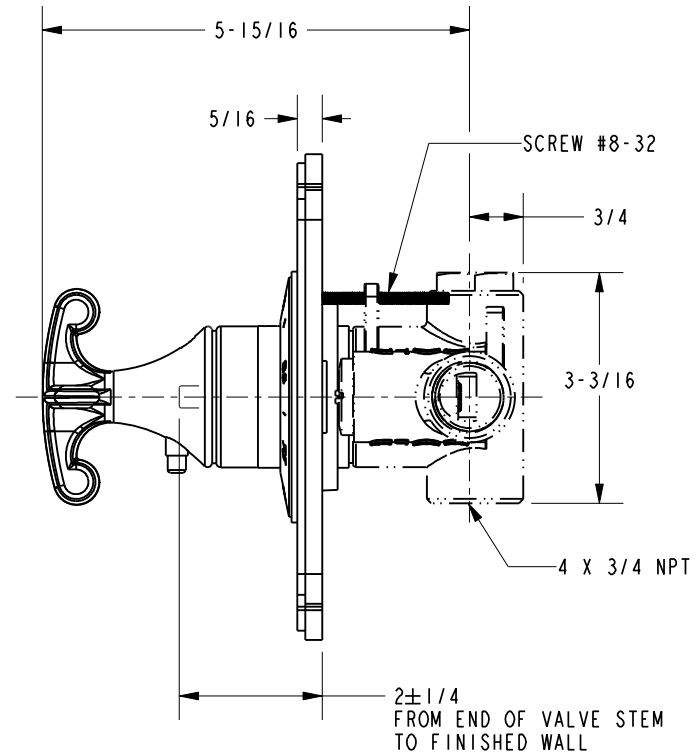
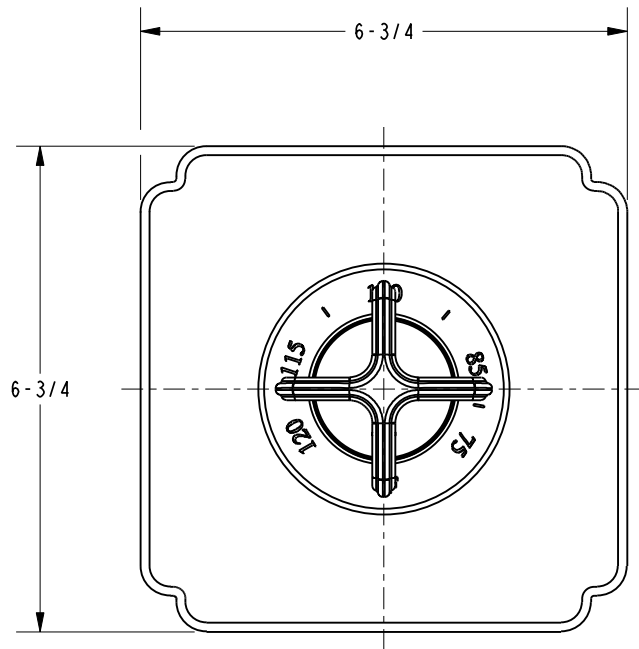

<b>BRASSTECH</b> INCORPORATED		2001 E. CARNEGIE AVE. SANTA ANA, CA 92705 (949) 417-5207	
DWG NO.	3-2524TS		REV C
SCALE .375	REF. -	SHEET 3 OF 3	