

4

3

2

1

BILL OF MATERIAL (CURRENT LEVEL)

ITEM	PT/ASSY	DESCRIPTION	TYPE	QTY.
1	2-659	TUB/SHOWER PLATE	ASSEMBLY	1
2	3-374	CROSS HANDLE AND ESC. ASM	ASSEMBLY	1
3	3-382	WALL TUB SPOUT ASSEMBLY	ASSEMBLY	1
4	2-503	SHOWER FLANGE ASM	ASSEMBLY	1
5	50822	8" SHWR ARM (201)	PART	1
6	2142	TRAD. SHOWER HEAD - SINGLE JET	ASSEMBLY	1
7	2-217	DIVERTER TRIM KIT	ASSEMBLY	1

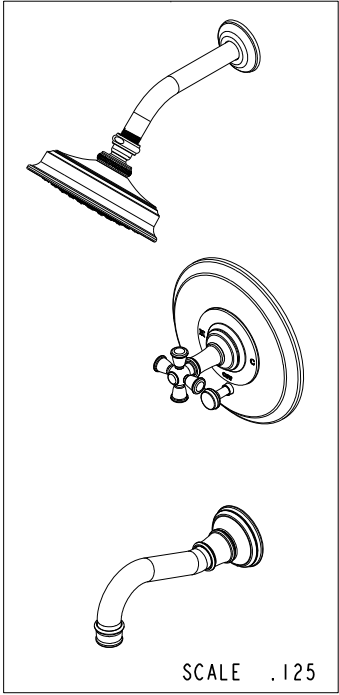
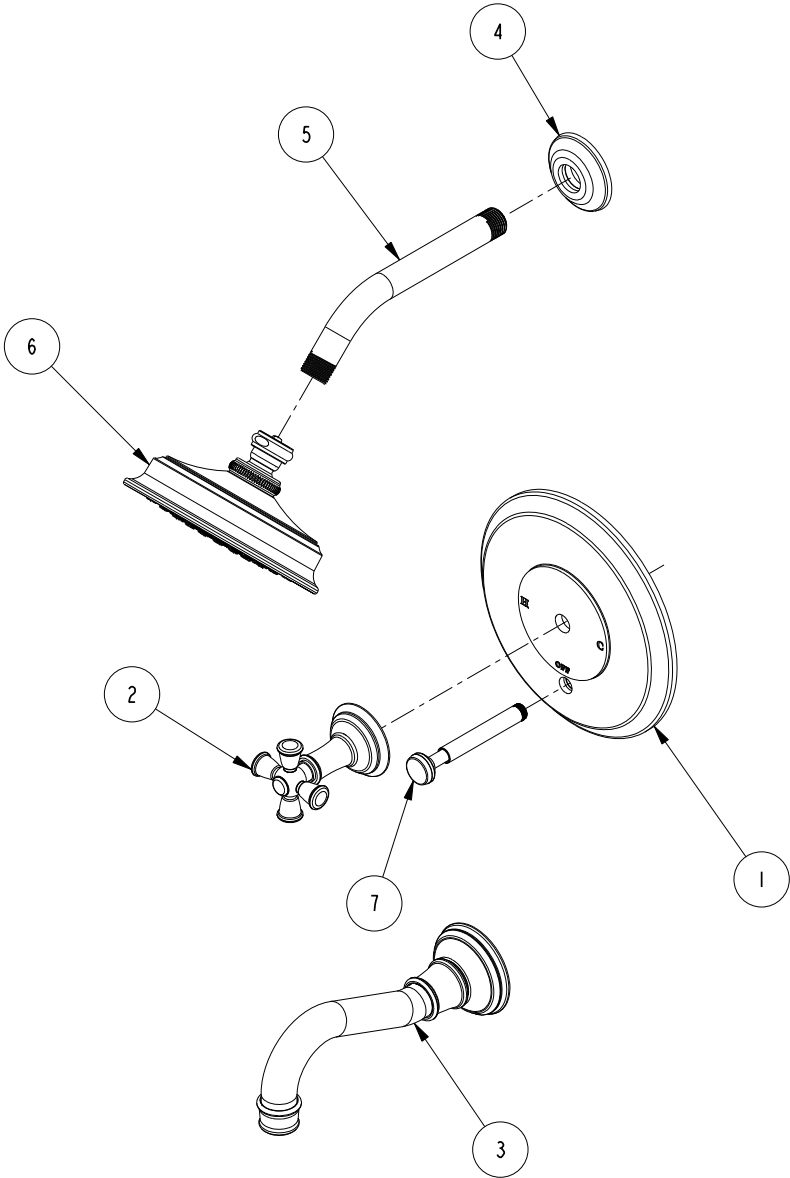

COPYRIGHT 2005 BRASSTECH, INC. THESE DRAWINGS AND THE DESIGNS DEPICTED HEREIN ARE THE PROPRIETARY PROPERTY OF BRASSTECH. ANY USE OR REPRODUCTION IS SUBJECT TO THE EXPRESS APPROVAL OF BRASSTECH. UNAUTHORIZED USE IS STRICTLY PROHIBITED. ALL RIGHTS RESERVED.

BRASSTECH
INCORPORATED

2001 E. CARNEGIE AVE.
SANTA ANA, CA 92705
(949) 417-5207

B/T TUB AND SHOWER TRIM KIT

ASSY. NO. 3-2462BP		-	-	-
SCALE .188	REF. -	SHEET 1 OF 3	REV	REV DESC
			EN-1266	05/14/10
			DATE	

4

3

2

1

SPECIFICATION DWG

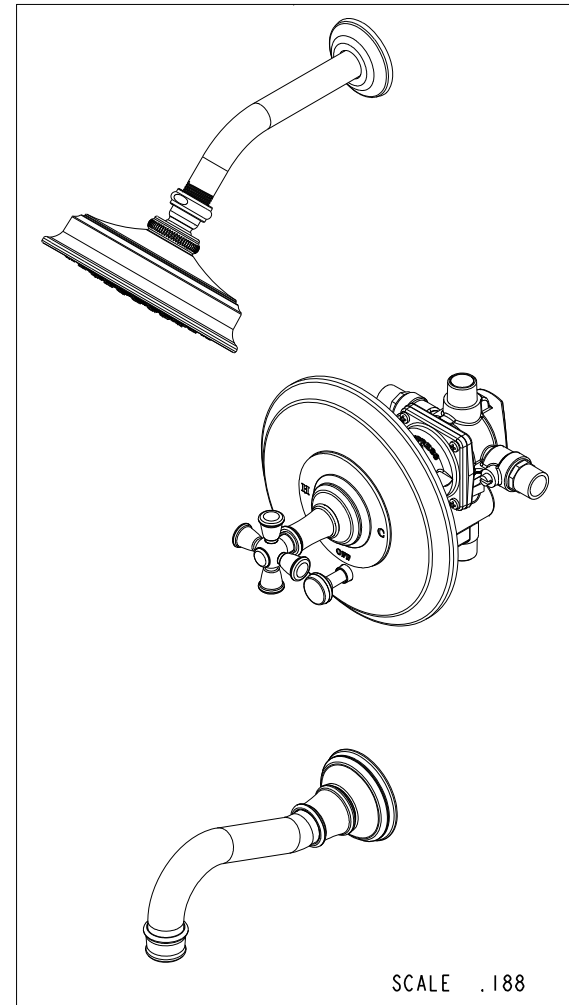
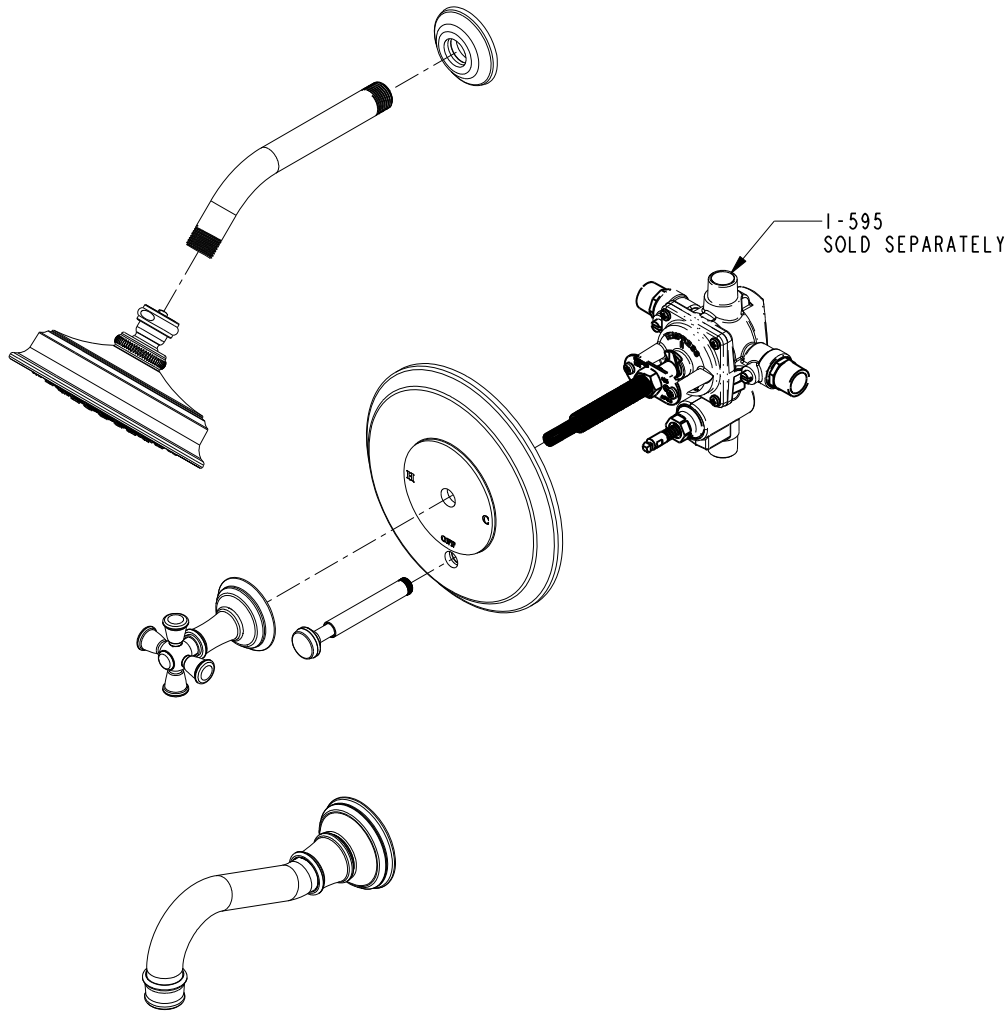

SCALE .188

DIMENSIONS ARE IN INCHES AND AN APPROXIMATION OF A TYPICAL INSTALLATION

COPYRIGHT 2005 BRASSTECH, INC. THESE DRAWINGS AND THE DESIGNS DEPICTED HEREIN ARE THE PROPRIETARY PROPERTY OF BRASSTECH. ANY USE OR REPRODUCTION IS SUBJECT TO THE EXPRESS APPROVAL OF BRASSTECH. UNAUTHORIZED USE IS STRICTLY PROHIBITED. ALL RIGHTS RESERVED.

BRASSTECH		2001 E. CARNEGIE AVE.
INCORPORATED		SANTA ANA, CA 92705
		(949) 417-5207
DWG NO.	3-2462BP	REV -
SCALE .188	REF. -	SHEET 2 OF 3

SPECIFICATION DWG

NOTES:

- 1 CUT STEM TO DIMENSION SHOWN
- 2 CUT ALL THREAD 1" SHORTER THAN STEM
- 3 PN: 1-595 TO BE SOLD SEPARATELY

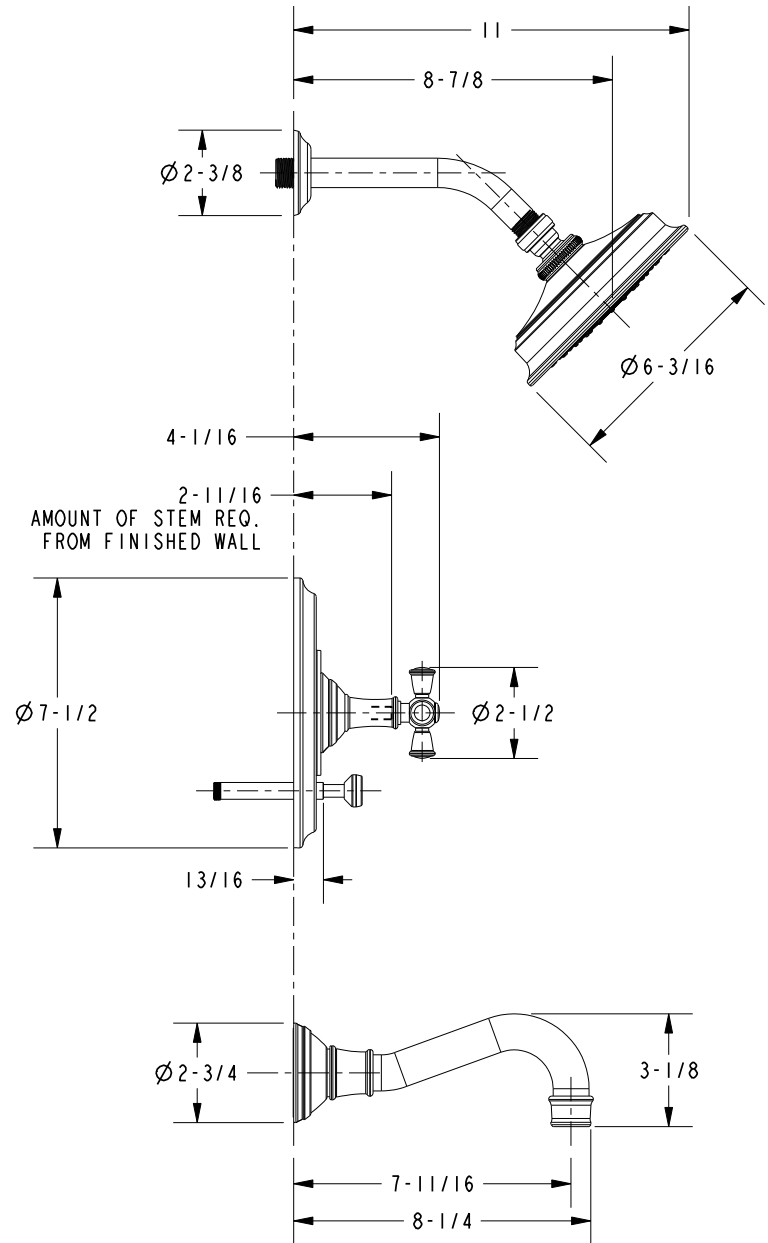
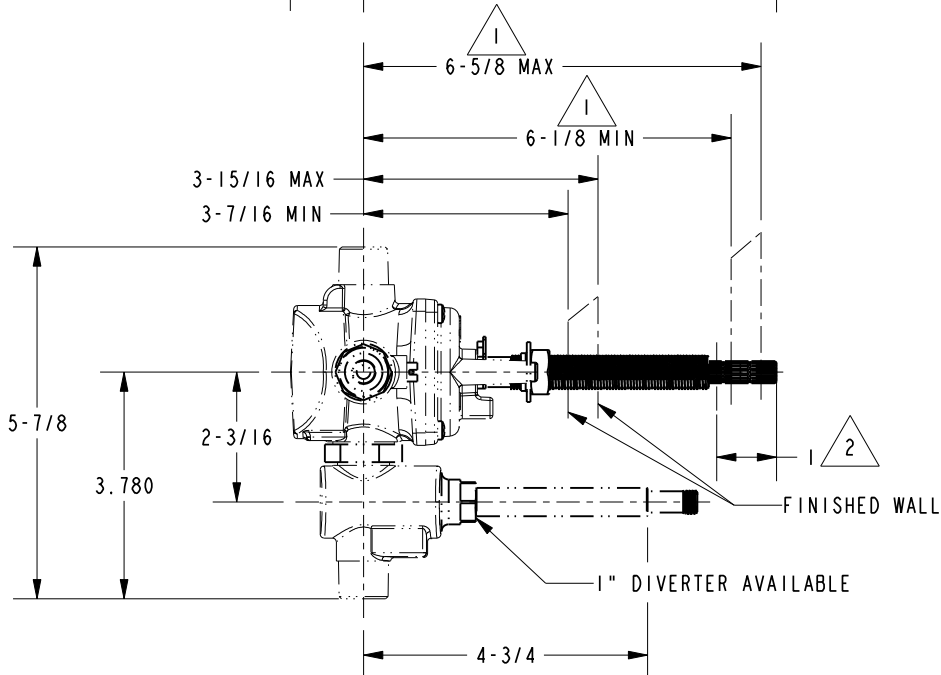
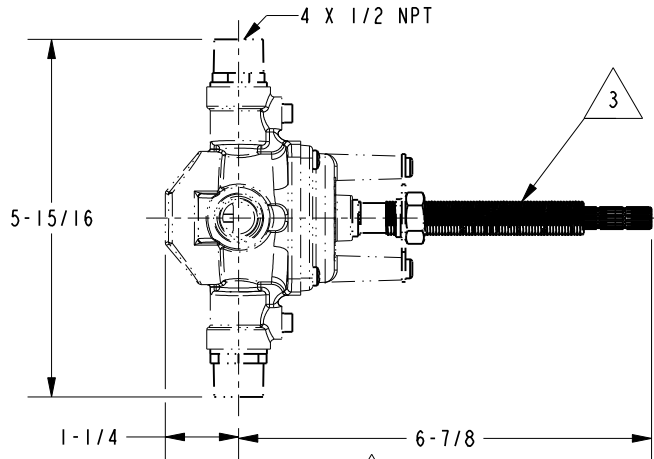

DIMENSIONS ARE IN INCHES AND AN APPROXIMATION OF A TYPICAL INSTALLATION

COPYRIGHT 2005 BRASSTECH, INC. THESE DRAWINGS AND THE DESIGNS DEPICTED HEREIN ARE THE PROPRIETARY PROPERTY OF BRASSTECH. ANY USE OR REPRODUCTION IS SUBJECT TO THE EXPRESS APPROVAL OF BRASSTECH. UNAUTHORIZED USE IS STRICTLY PROHIBITED. ALL RIGHTS RESERVED.

BRASSTECH		2001 E. CARNEGIE AVE.
INCORPORATED		SANTA ANA, CA 92705
		(949) 417-5207
DWG NO.	3-2462BP	REV -
SCALE .313	REF. -	SHEET 3 OF 3