

4

3

2

BILL OF MATERIAL (CURRENT LEVEL)

ITEM	PT/ASSY	DESCRIPTION	TYPE	QTY.
1	2-659	TUB/SOWER PLATE	ASSEMBLY	1
2	3-379	LEVER HANDLE ASSEMBLY	ASSEMBLY	1
3	3-388	SPOUT ASM WITH ESCUTCHEON TUB	ASSEMBLY	1
4	2-503	SHOWER FLANGE ASM	ASSEMBLY	1
5	50822	8" SHWR ARM (201)	PART	1
6	2142	TRAD. SHOWER HEAD - SINGLE JET	ASSEMBLY	1
7	2-217	DIVERTER TRIM KIT	ASSEMBLY	1

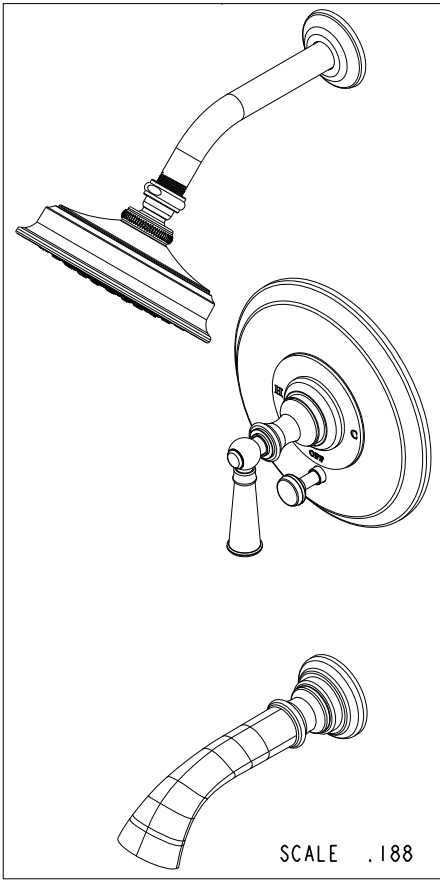
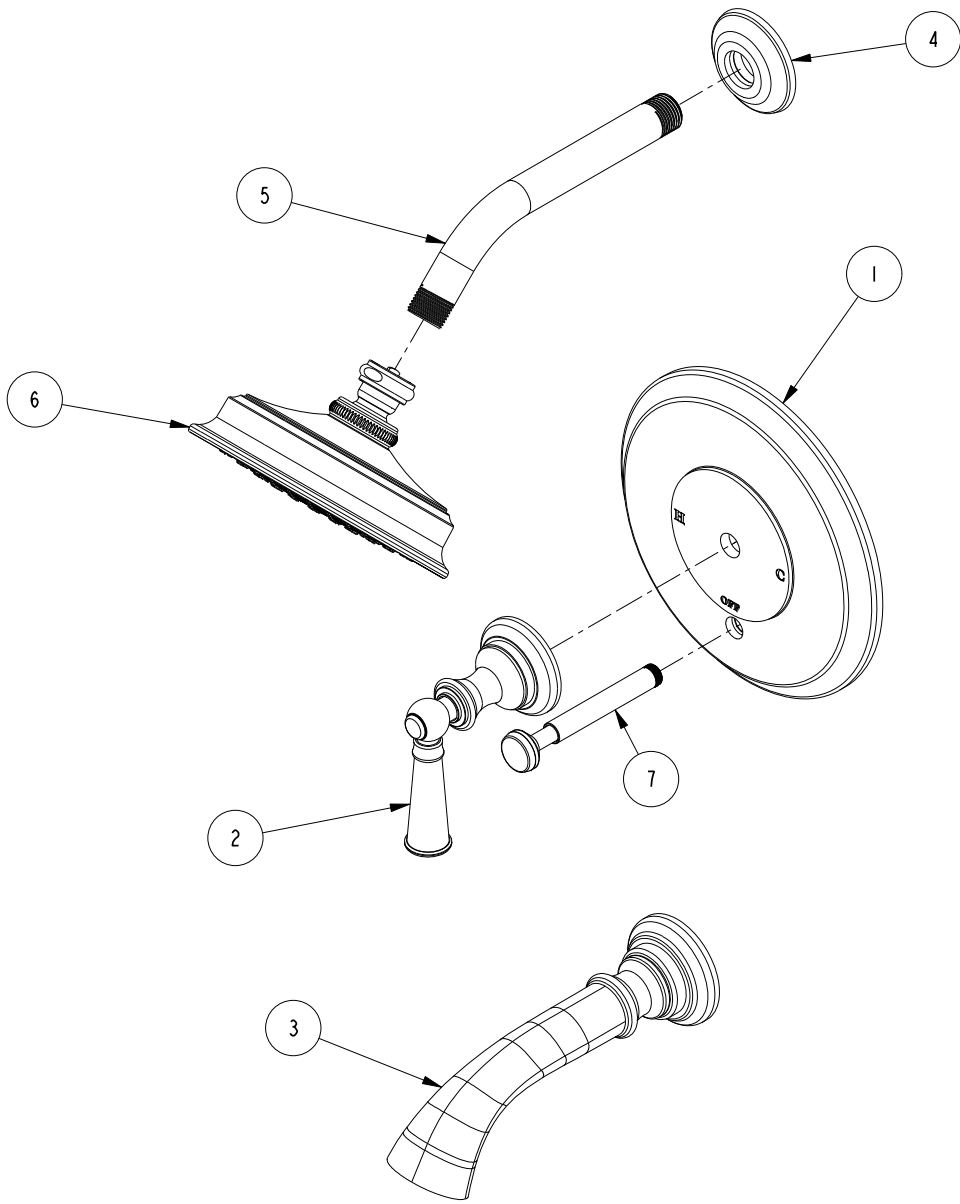

COPYRIGHT 2005 BRASSTECH, INC. THESE DRAWINGS AND THE DESIGNS DEPICTED HEREIN ARE THE PROPRIETARY PROPERTY OF BRASSTECH. ANY USE OR REPRODUCTION IS SUBJECT TO THE EXPRESS APPROVAL OF BRASSTECH. UNAUTHORIZED USE IS STRICTLY PROHIBITED. ALL RIGHTS RESERVED.

BRASSTECH
 INCORPORATED
 2001 E. CARNEGIE AVE.
 SANTA ANA, CA 92705
 (949) 417-5207

B/P TUB AND SHOWER TRIM KIT

ASSY. NO. 3-2452BP		-	-	-
SCALE .250	REF. -	SHEET 1 OF 3	REV	REV DESC
				DATE 05/14/10

4

3

2

1

4 3 2 1

SPECIFICATION DWG

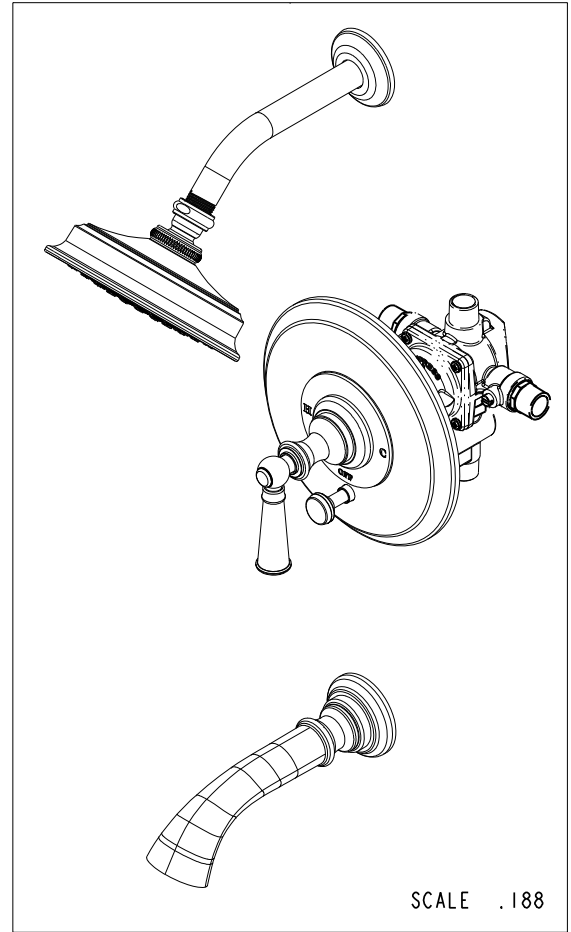
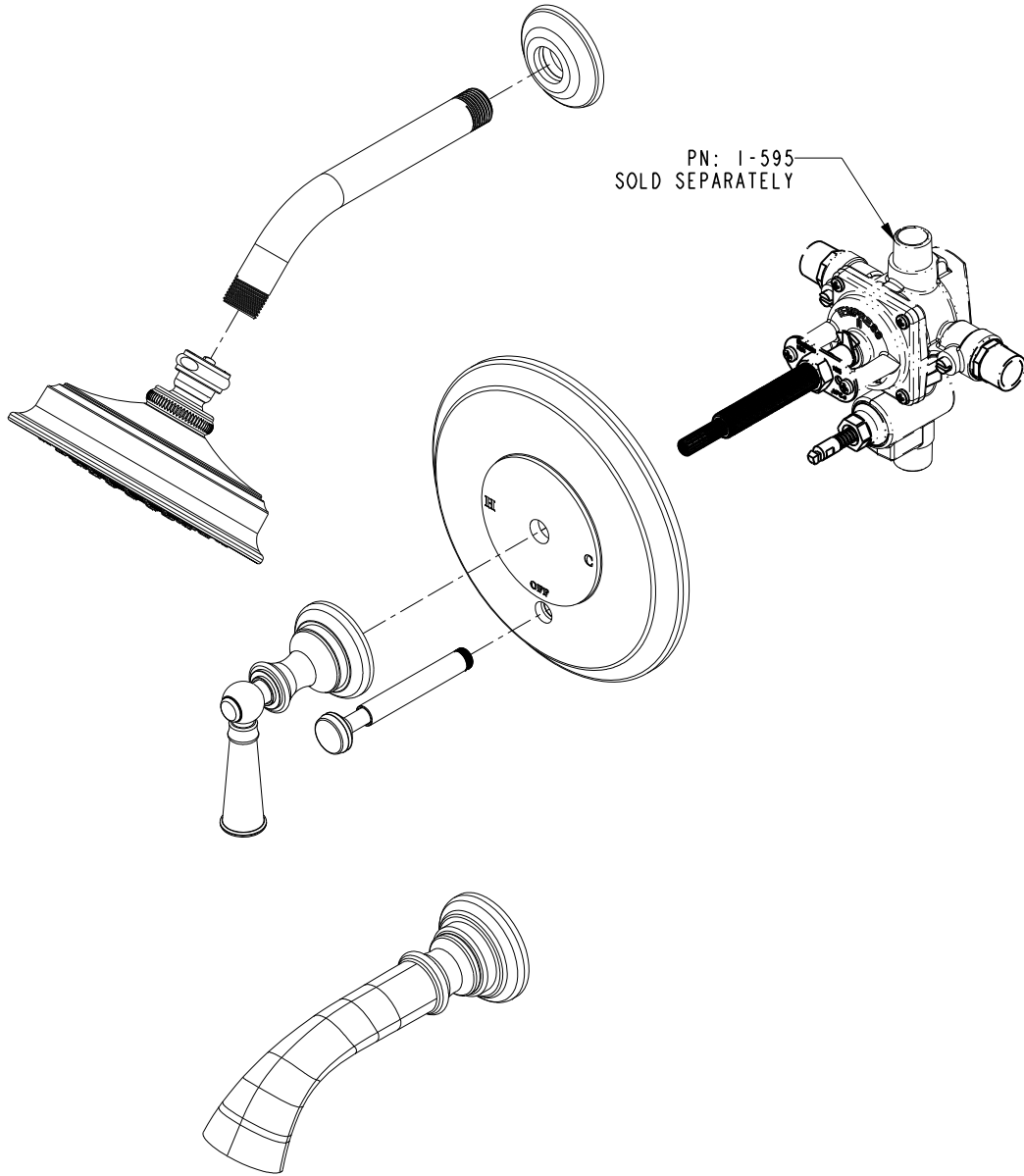

DIMENSIONS ARE IN INCHES AND AN APPROXIMATION OF A TYPICAL INSTALLATION

COPYRIGHT 2005 BRASSTECH, INC. THESE DRAWINGS AND THE DESIGNS DEPICTED HEREIN ARE THE PROPRIETARY PROPERTY OF BRASSTECH. ANY USE OR REPRODUCTION IS SUBJECT TO THE EXPRESS APPROVAL OF BRASSTECH. UNAUTHORIZED USE IS STRICTLY PROHIBITED. ALL RIGHTS RESERVED.

BRASSTECH		2001 E. CARNEGIE AVE.	
INCORPORATED		SANTA ANA, CA 92705	
		(949) 417-5207	
DWG NO.	3-2452BP		REV -
SCALE .250	REF. -	SHEET 2 OF 3	

SPECIFICATION DWG

NOTES:

- 1 CUT STEM TO DIMENSION SHOWN.
- 2 CUT ALL-THREAD 3/4" SHORTER THAN STEM

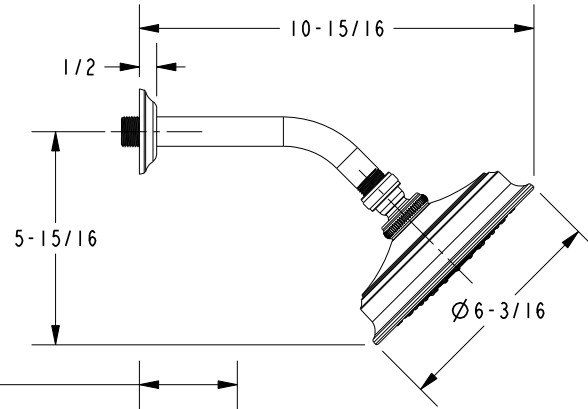
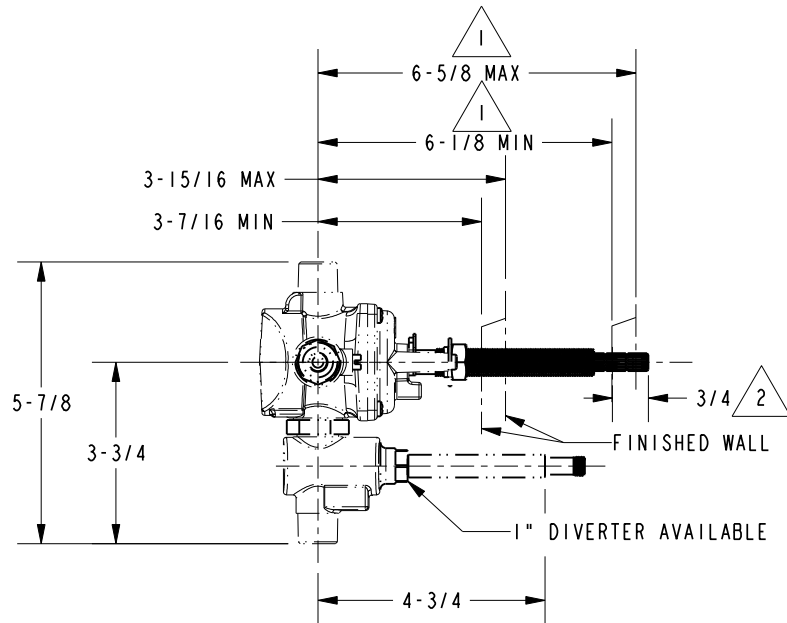
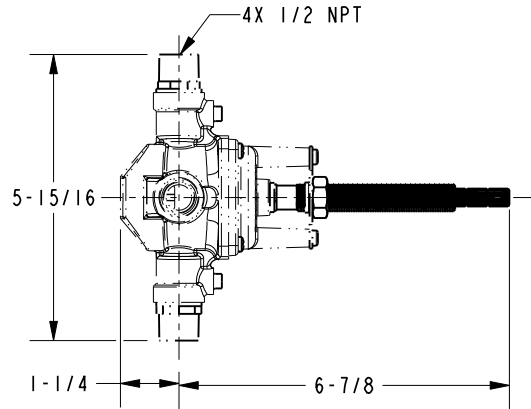

2-11/16
AMOUNT OF STEM REQ.
FROM FINISHED WALL

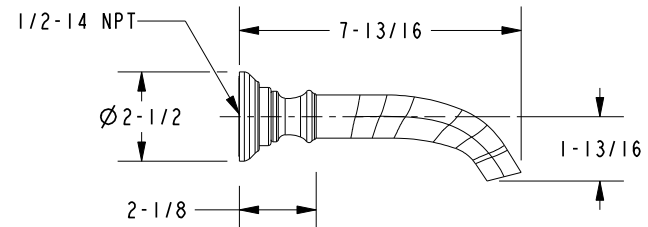
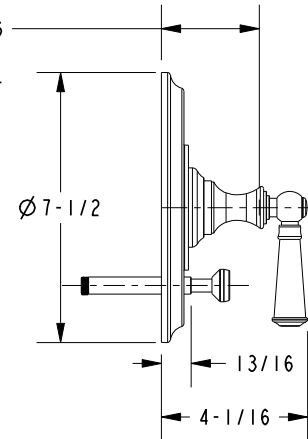

SCALE .188

DIMENSIONS ARE IN INCHES AND AN APPROXIMATION OF A TYPICAL INSTALLATION

COPYRIGHT 2005 BRASSTECH, INC. THESE DRAWINGS AND THE DESIGNS DEPICTED HEREIN ARE THE PROPRIETARY PROPERTY OF BRASSTECH. ANY USE OR REPRODUCTION IS SUBJECT TO THE EXPRESS APPROVAL OF BRASSTECH. UNAUTHORIZED USE IS STRICTLY PROHIBITED. ALL RIGHTS RESERVED.

BRASSTECH		2001 E. CARNEGIE AVE.
INCORPORATED		SANTA ANA, CA 92705
		(949) 417-5207
DWG NO.	3-2452BP	REV -
SCALE .250	REF. -	SHEET 3 OF 3