

NOTES:

- (N1) 1. FIT / FORM / FUNCTION SHALL FOLLOW PS-E.008.
- 2. REMOVE AND DISCARD THIS PLASTIC NUT AND GASKET.

J.A.
7/13/18

BILL OF MATERIAL (CURRENT LEVEL)

ITEM	PT/ASSY	DESCRIPTION	TYPE	QTY.
1	5-034	AIR GAP BODY	ASSEMBLY	1
2	3210-5751	AIR CAP ASM	ASSEMBLY	1

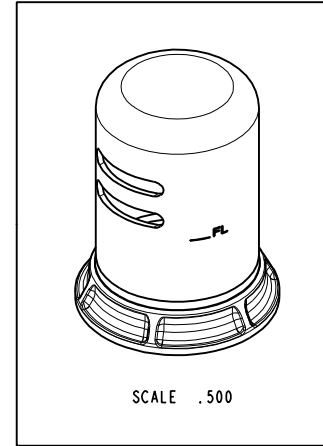

UNITS ARE: INCHES [MM]
 TOLERANCES ARE:
 FRACTIONS DECIMALS ANGLES
 $\pm 1/16"$.X $\pm .1$ [2.5] $\pm 1^\circ$
 .XX $\pm .06$ [1.5]
 (X.XXX) DENOTES CRITICAL DIMS.
 ALL THREADS ARE CRITICAL

BRASSTECH 2001 CARNEGIE AVE.
 INCORPORATED SANTA ANA, CA 92705
 (949) 417-5207

AIR GAP ASM

DRAWN JINSON 02/07/17
 CHECKED RAVINDRA 02/07/17
 APPROVED J.M. 02/07/17

DWG NO. 3210-5711 REV -
 SCALE .500 REF. - SHEET 1 OF 2

COPYRIGHT 2005 BRASSTECH, INC.
 THESE DRAWINGS AND THE DESIGNS
 DEPICTED HEREIN ARE THE PROPRIETARY
 PROPERTY OF BRASSTECH. ANY USE
 OR REPRODUCTION IS SUBJECT TO
 THE EXPRESS APPROVAL OF BRASSTECH.
 UNAUTHORIZED USE IS STRICTLY
 PROHIBITED. ALL RIGHTS RESERVED.

ZONE	REV	DESCRIPTION	DATE	APPROVED
-	-	EN-3076	02/07/17	J.M.

TESTING	ASSEMBLY	PLATING	POLISHING	MACHINING	TOOLING	FIXTURE #	APPLICATION
-	-	-	-	-	-	-	REMOVE ALL BURRS AND SHARP EDGES

