

NOTES:

(N1) 1. FIT / FORM / FUNCTION SHALL FOLLOW PS-E.008.

BILL OF MATERIAL (CURRENT LEVEL)

ITEM	PT/ASSY	DESCRIPTION	TYPE	QTY.
1	3-327	WALL LAVATORY SPOUT ASM	ASSEMBLY	1
2	3-577	HANDLE CROSS/ ESC ASM	ASSEMBLY	2

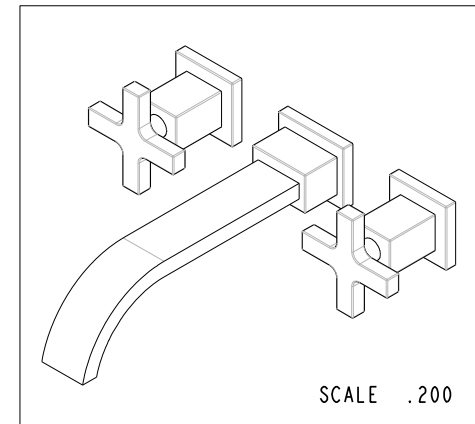
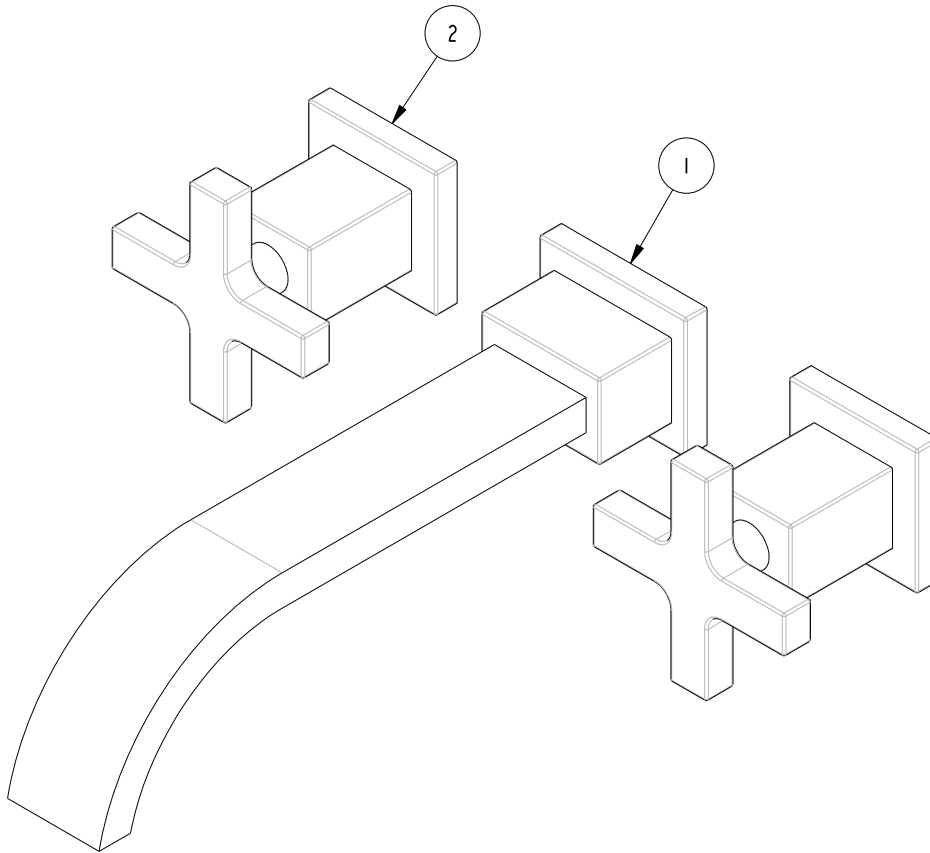

ZONE	REV	DESCRIPTION	DATE	APPROVED
-	-	EN-3084c	10/05/16	AN

COPYRIGHT 2005 BRASSTECH, INC. THESE DRAWINGS AND THE DESIGNS DEPICTED HEREIN ARE THE PROPRIETARY PROPERTY OF BRASSTECH. ANY USE OR REPRODUCTION IS SUBJECT TO THE EXPRESS APPROVAL OF BRASSTECH. UNAUTHORIZED USE IS STRICTLY PROHIBITED. ALL RIGHTS RESERVED.

TESTING	-	-	-
ASSEMBLY	-	-	-
PLATING	-	-	-
POLISHING	-	NEXT ASSY	USED ON
MACHINING	-	APPLICATION	
TOOLING FIXTURE #	REMOVE ALL BURRS AND SHARP EDGES		

UNITS ARE: INCHES [MM]		
TOLERANCES ARE:		
FRACTIONS	DECIMALS	ANGLES
±1/16"	.X ±.1 (2.5)	±1°
	.XX ±.06 (1.5)	
(X.XXX) DENOTES CRITICAL DIMS.		
ALL THREADS ARE CRITICAL		
DRAWN	AN	10/05/16
CHECKED	AN	10/05/16
APPROVED	AN	10/05/16

BRASSTECH 2001 CARNEGIE AVE.
INCORPORATED SANTA ANA, CA 92705
(949) 417-5207

WALL MOUNT LAV FAUCET

DWG NO.	3-2061	REV	-
SCALE	.450	REF.	-
SHEET	1	OF	3

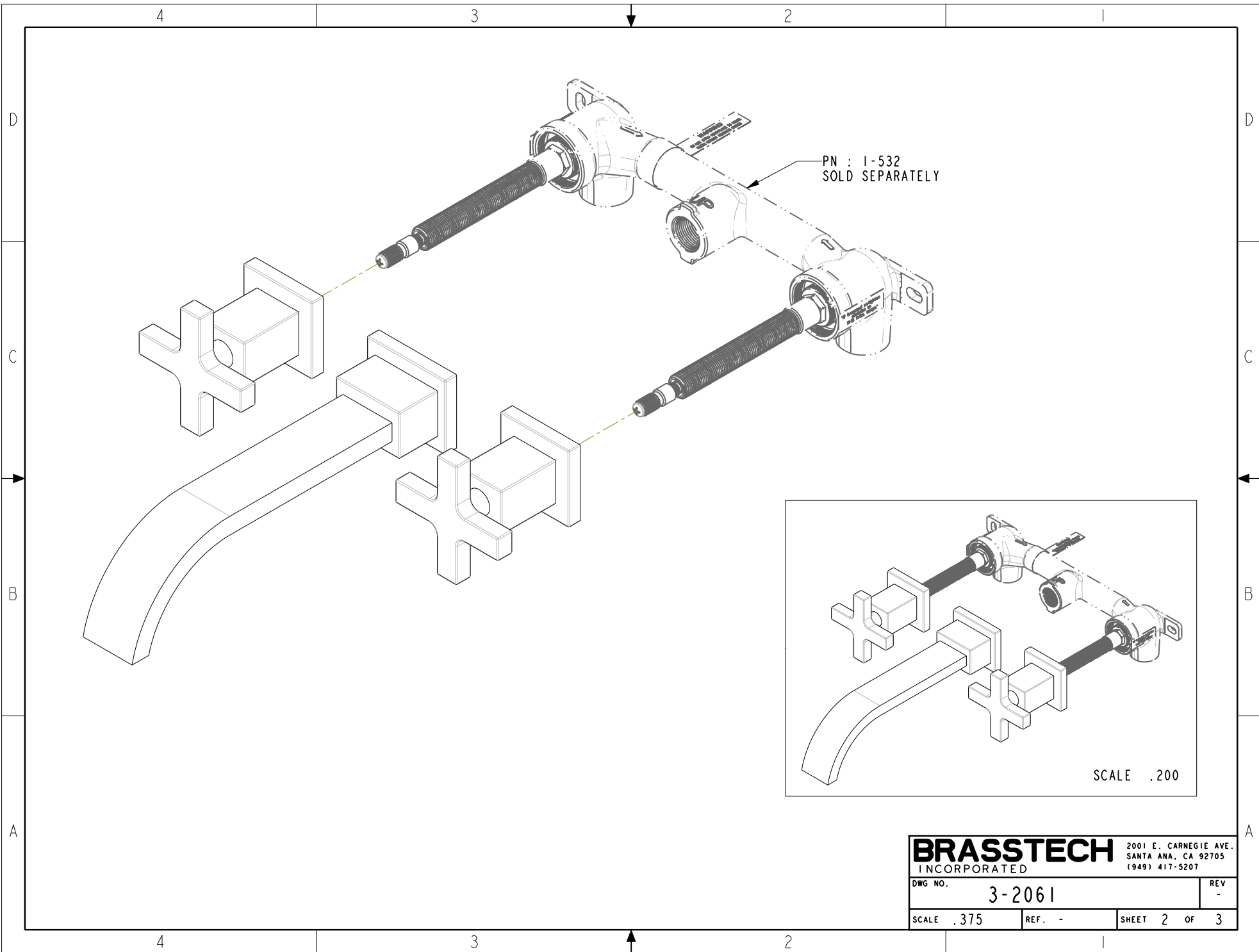

NOTES:

- 1. CUT STEM AS SHOWN.
- 2. CUT ALL THREADS 1/2" SHORTER THAN STEM.

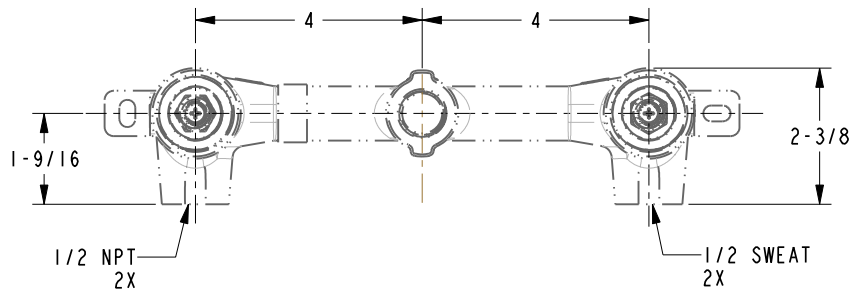
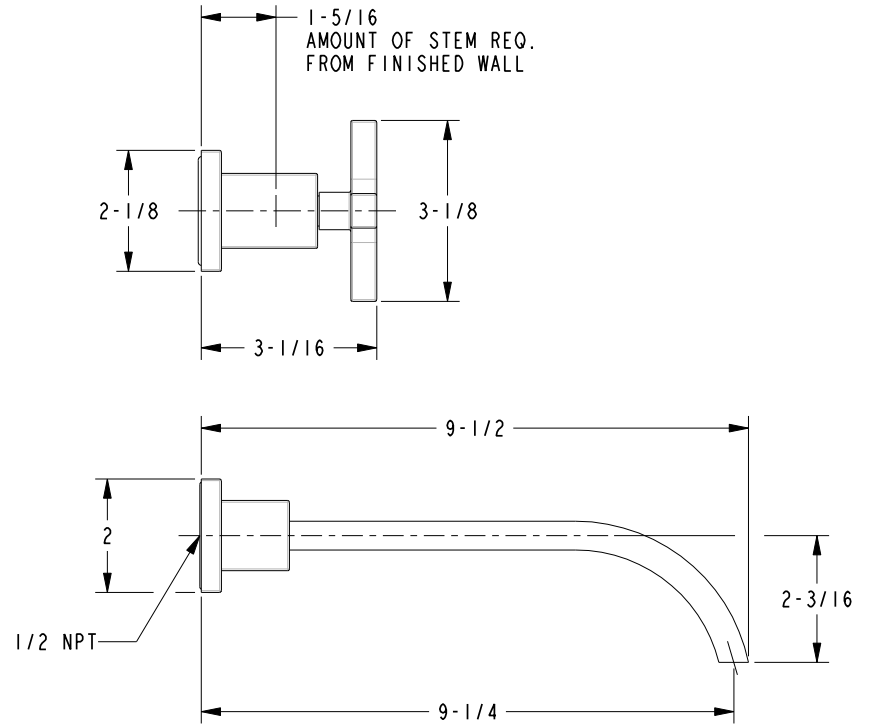
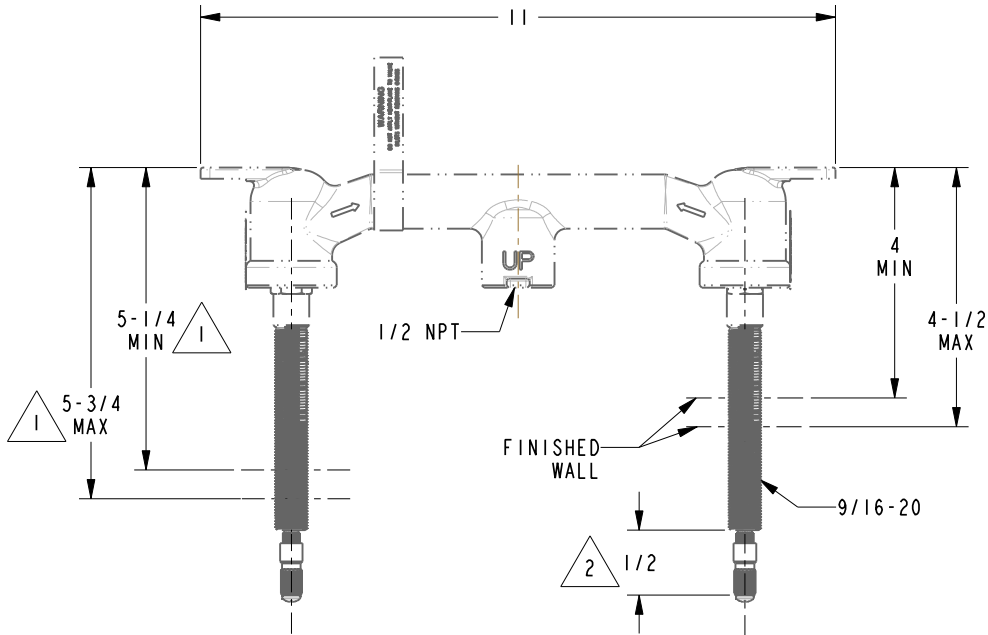

BRASSTECH		2001 E. CARNEGIE AVE. SANTA ANA, CA 92705 (949) 417-5207	
DWG NO.	3-2061		REV -
SCALE	.300	REF. -	SHEET 3 OF 3