

| BILL OF MATERIAL (CURRENT LEVEL) |         |                           |          |      |
|----------------------------------|---------|---------------------------|----------|------|
| ITEM                             | PT/ASSY | DESCRIPTION               | TYPE     | QTY. |
| 1                                | 1-507   | R/T 3-VALVE/QUICK CONNECT | ASSEMBLY | 1    |
| 2                                | 3-1667  | TRIM KIT - 3-1667         | ASSEMBLY | 1    |

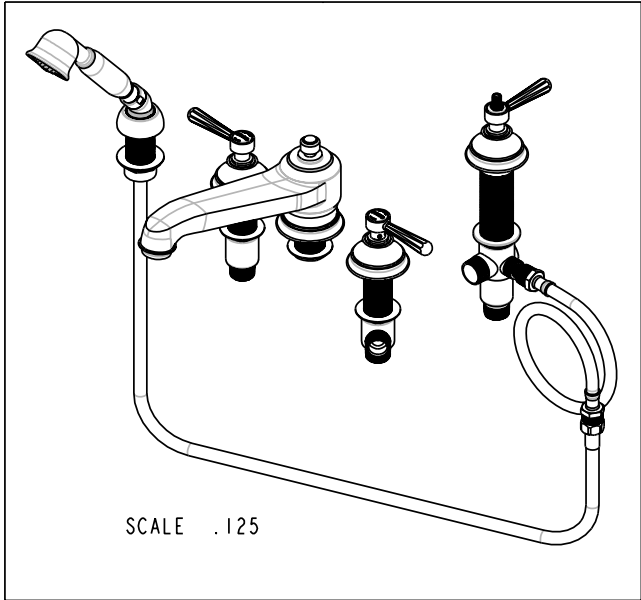

NOTE: RECOMMENDED VALVE(S), SHOWN WITH TRIM KIT, SOLD SEPERATELY

COPYRIGHT 2005 BRASSTECH, INC. THESE DRAWINGS AND THE DESIGNS DEPICTED HEREIN ARE THE PROPRIETARY PROPERTY OF BRASSTECH. ANY USE OR REPRODUCTION IS SUBJECT TO THE EXPRESS APPROVAL OF BRASSTECH. UNAUTHORIZED USE IS STRICTLY PROHIBITED. ALL RIGHTS RESERVED.

**BRASSTECH**  
INCORPORATED  
2001 E. CARNEGIE AVE.  
SANTA ANA, CA 92705  
(949) 417-5207

R/T W/HANDSHWR

|            |        |              |          |
|------------|--------|--------------|----------|
| ASSY. NO.  |        | 1667         |          |
| SCALE .200 | REF. - | SHEET 1 OF 3 | REV      |
|            |        |              | REV DESC |
|            |        |              | DATE     |

|   |         |          |
|---|---------|----------|
| B | EN-1167 | 12/19/08 |
| A | EO-0904 | 10/30/07 |
| - | EO-0299 | 03/04/04 |

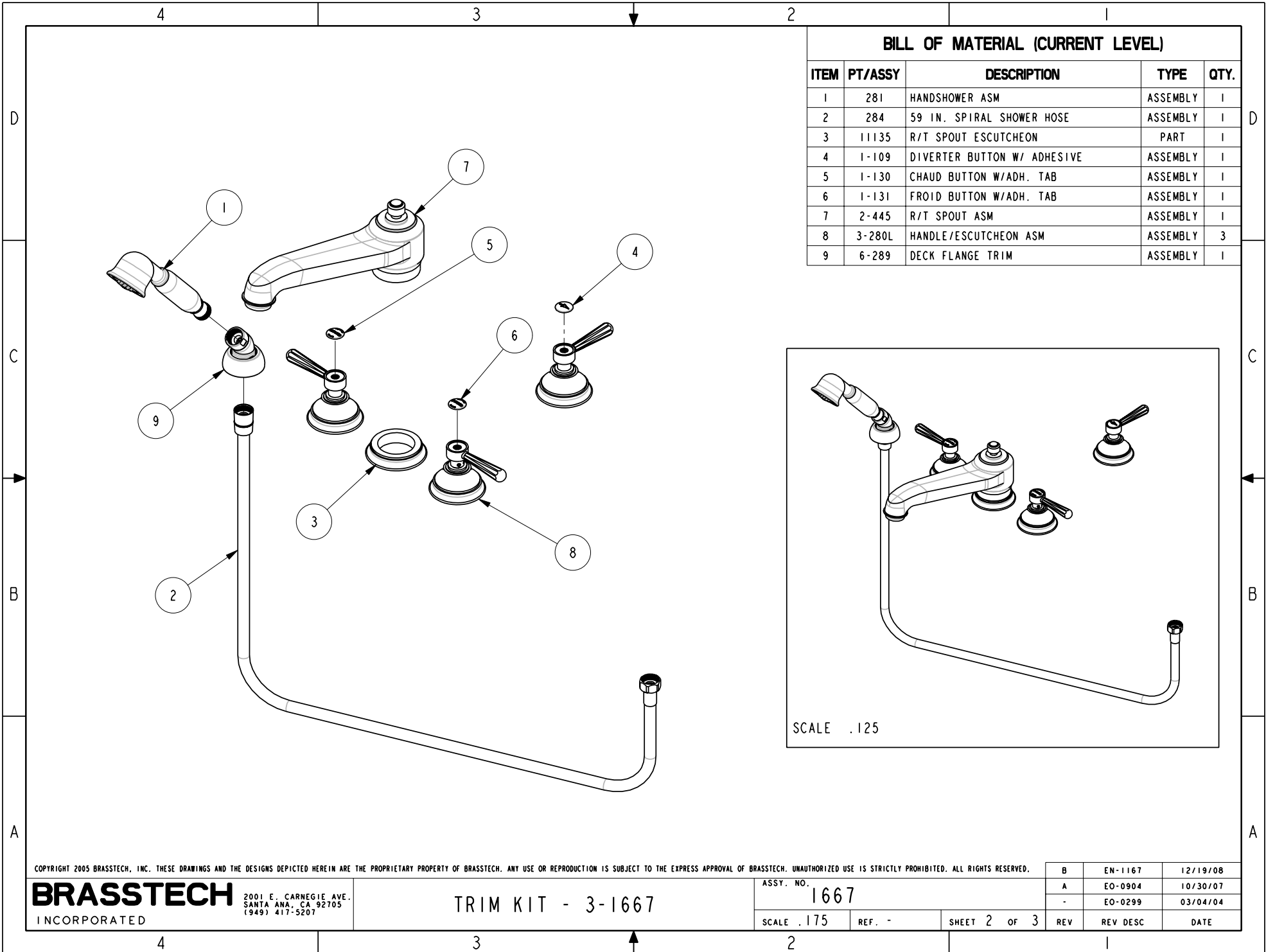

| BILL OF MATERIAL (CURRENT LEVEL) |         |                             |          |      |
|----------------------------------|---------|-----------------------------|----------|------|
| ITEM                             | PT/ASSY | DESCRIPTION                 | TYPE     | QTY. |
| 1                                | 281     | HANDSHOWER ASM              | ASSEMBLY | 1    |
| 2                                | 284     | 59 IN. SPIRAL SHOWER HOSE   | ASSEMBLY | 1    |
| 3                                | 11135   | R/T SPOUT ESCUTCHEON        | PART     | 1    |
| 4                                | 1-109   | DIVERTER BUTTON W/ ADHESIVE | ASSEMBLY | 1    |
| 5                                | 1-130   | CHAUD BUTTON W/ADH. TAB     | ASSEMBLY | 1    |
| 6                                | 1-131   | FROID BUTTON W/ADH. TAB     | ASSEMBLY | 1    |
| 7                                | 2-445   | R/T SPOUT ASM               | ASSEMBLY | 1    |
| 8                                | 3-280L  | HANDLE/ESCUTCHEON ASM       | ASSEMBLY | 3    |
| 9                                | 6-289   | DECK FLANGE TRIM            | ASSEMBLY | 1    |

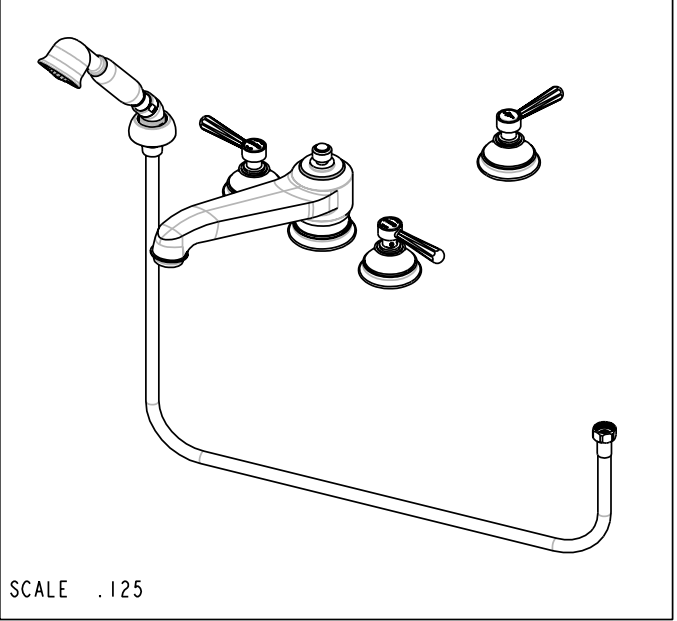

COPYRIGHT 2005 BRASSTECH, INC. THESE DRAWINGS AND THE DESIGNS DEPICTED HEREIN ARE THE PROPRIETARY PROPERTY OF BRASSTECH. ANY USE OR REPRODUCTION IS SUBJECT TO THE EXPRESS APPROVAL OF BRASSTECH. UNAUTHORIZED USE IS STRICTLY PROHIBITED. ALL RIGHTS RESERVED.

**BRASSTECH**  
INCORPORATED  
2001 E. CARNEGIE AVE.  
SANTA ANA, CA 92705  
(949) 417-5207

TRIM KIT - 3-1667

|           |      |          |   |
|-----------|------|----------|---|
| ASSY. NO. | 1667 |          |   |
| SCALE     | .175 | REF.     | - |
| SHEET     | 2    | OF       | 3 |
| REV       |      | REV DESC |   |
|           |      | DATE     |   |

|   |         |          |
|---|---------|----------|
| B | EN-1167 | 12/19/08 |
| A | EO-0904 | 10/30/07 |
| - | EO-0299 | 03/04/04 |

**SPECIFICATION DWG**

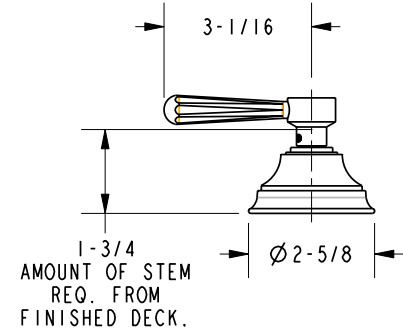
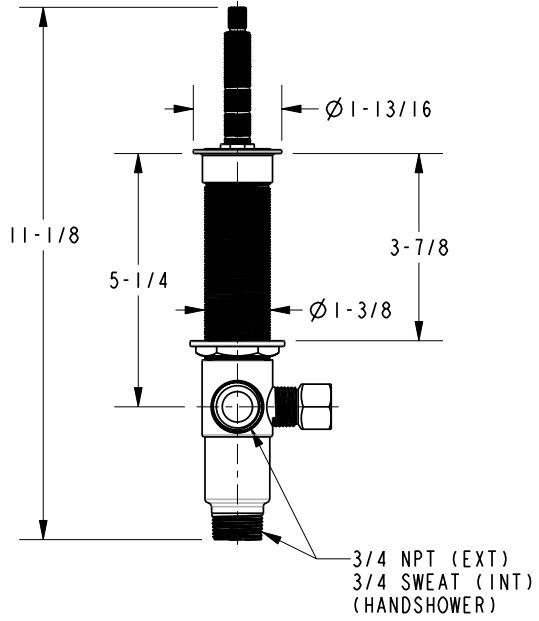
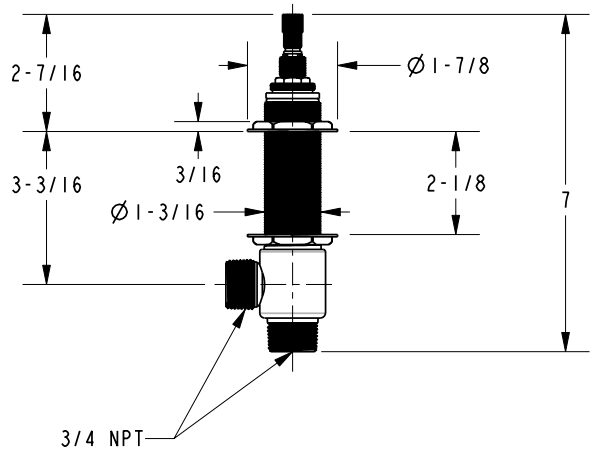
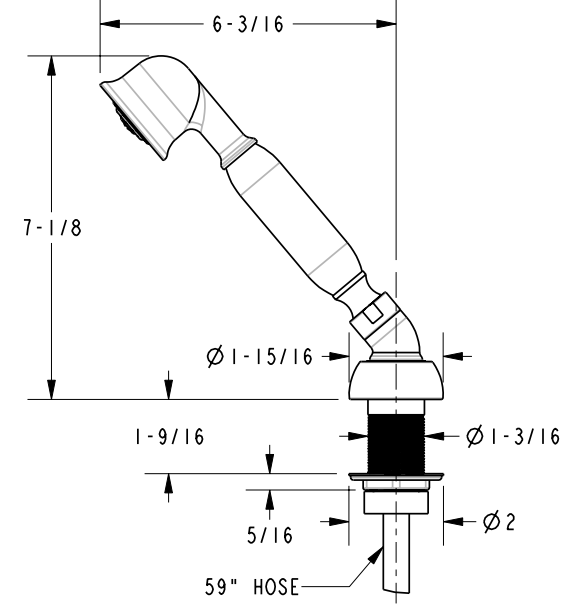
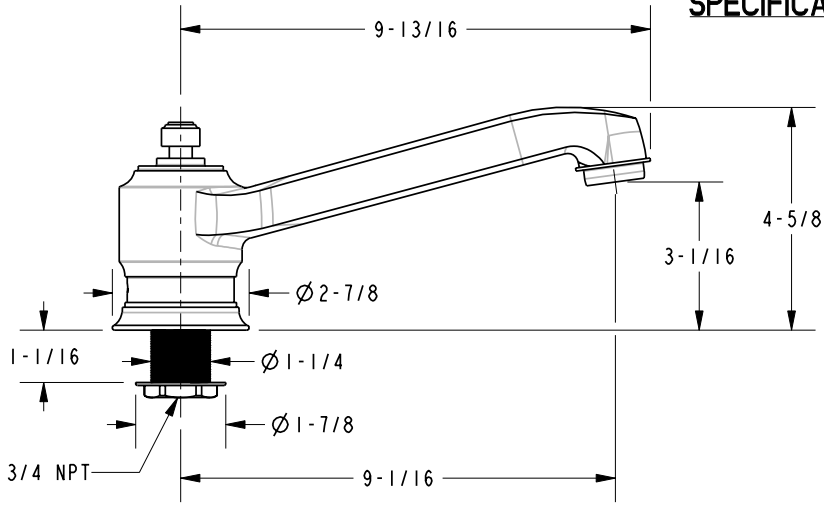

DIMENSIONS ARE IN INCHES AND AN APPROXIMATION OF A TYPICAL INSTALLATION

COPYRIGHT 2005 BRASSTECH, INC. THESE DRAWINGS AND THE DESIGNS DEPICTED HEREIN ARE THE PROPRIETARY PROPERTY OF BRASSTECH. ANY USE OR REPRODUCTION IS SUBJECT TO THE EXPRESS APPROVAL OF BRASSTECH. UNAUTHORIZED USE IS STRICTLY PROHIBITED. ALL RIGHTS RESERVED.

|                  |      |                       |        |
|------------------|------|-----------------------|--------|
| <b>BRASSTECH</b> |      | 2001 E. CARNEGIE AVE. |        |
| INCORPORATED     |      | SANTA ANA, CA 92705   |        |
|                  |      | (949) 417-5207        |        |
| DWG NO.          | 1667 | REV                   | B      |
| SCALE            | .250 | REF.                  | -      |
|                  |      | SHEET                 | 3 OF 3 |