

NOTES:

(N1) 1. FIT / FORM / FUNCTION SHALL FOLLOW PS-E.008.

BILL OF MATERIAL (CURRENT LEVEL)

ITEM	PT/ASSY	DESCRIPTION	TYPE	QTY.
1	20-287	GRAB BAR MOUNTING HARDWARE PACK	ASSEMBLY	2
2	5083S0	24" GRAB BAR BRAZE ASM	ASSEMBLY	1
3	40679	DECORATIVE RING	PART	2
4	92308	SCRW, M5 X 5 SKT HD CUP PT SS	PART	2

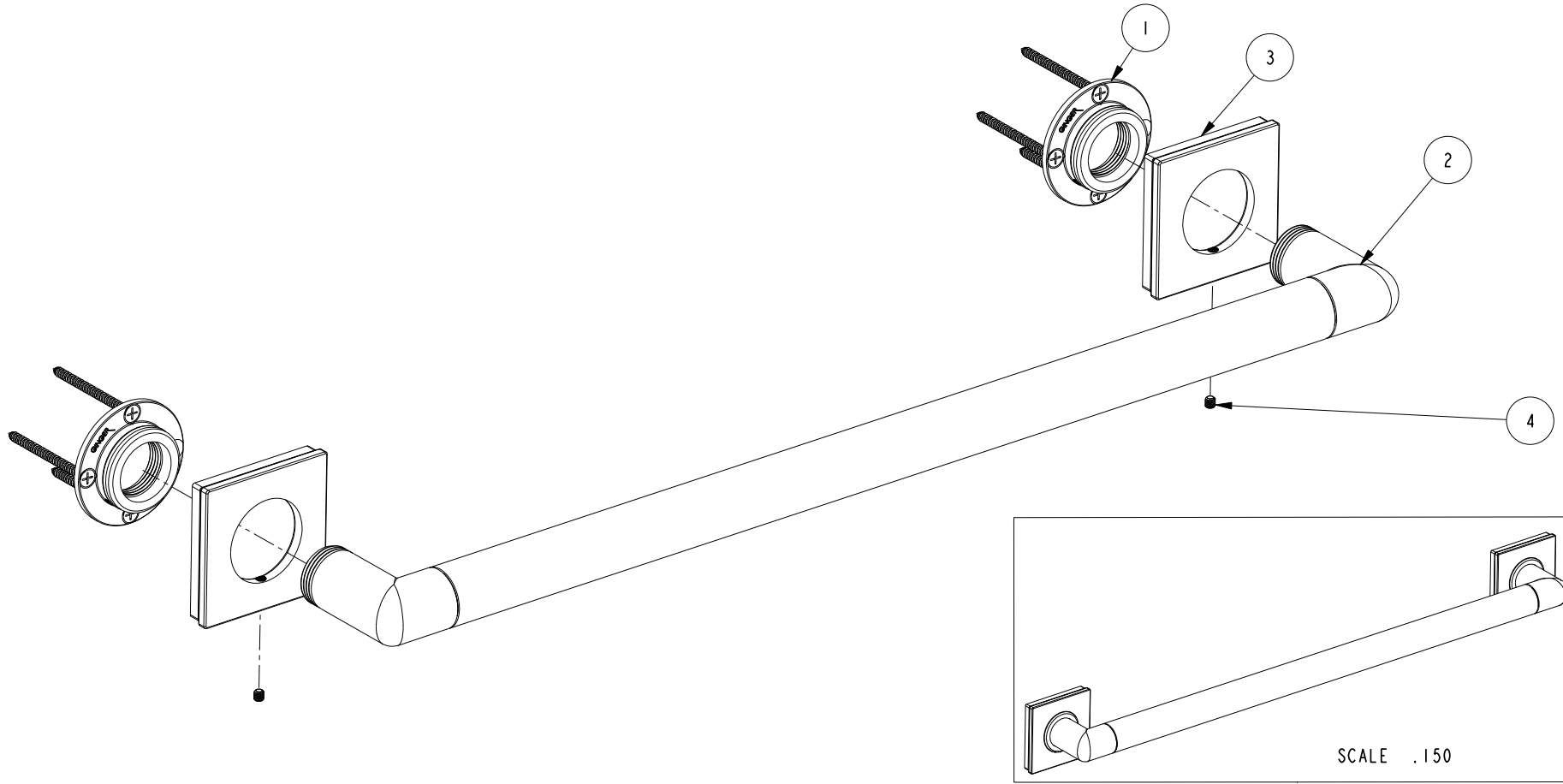

SCALE .150

COPYRIGHT 2005 BRASSTECH, INC.
 THESE DRAWINGS AND THE DESIGNS
 DEPICTED HEREIN ARE THE PROPRIETARY
 PROPERTY OF BRASSTECH. ANY USE
 OR REPRODUCTION IS SUBJECT TO
 THE EXPRESS APPROVAL OF BRASSTECH.
 UNAUTHORIZED USE IS STRICTLY
 PROHIBITED. ALL RIGHTS RESERVED.

TESTING	-	-	-
ASSEMBLY	-	-	-
PLATING	-	-	-
POLISHING	-	NEXT ASSY	USED ON
MACHINING	-	APPLICATION	
TOOLING FIXTURE #	REMOVE ALL BURRS AND SHARP EDGES		

UNITS ARE: INCHES [MM]
 TOLERANCES ARE:
 FRACTIONS DECIMALS ANGLES
 $\pm 1/16"$.X $\pm .1$ [2.5] $\pm 1^\circ$
 .XX $\pm .06$ [1.5]
 (X.XXX) DENOTES CRITICAL DIMS.
 ALL THREADS ARE CRITICAL

BRASSTECH 2001 CARNEGIE AVE.
 INCORPORATED SANTA ANA, CA 92705
 (949) 417-5207

GRAB BAR 24"

-	-	EN-3279b	07/13/17	J.M.
ZONE	REV	DESCRIPTION	DATE	APPROVED

DWG NO.	3140-3924	REV	-
APPROVED	J.M.	07/13/17	
SCALE	.312	REF.	-
SHEET	1	OF	2

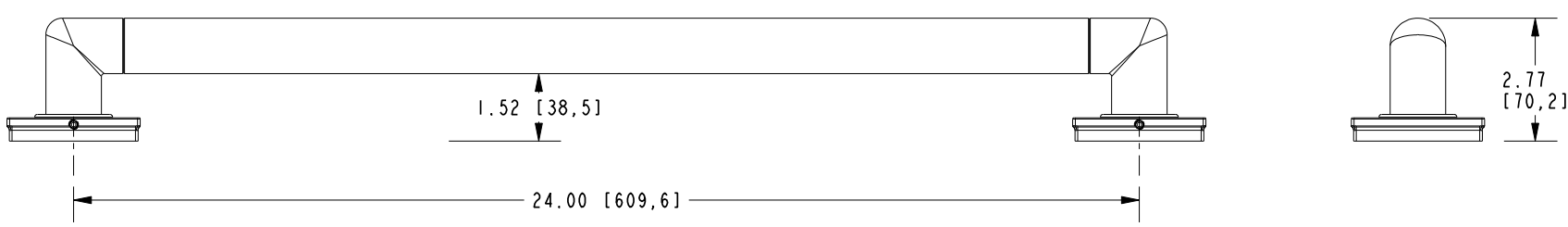
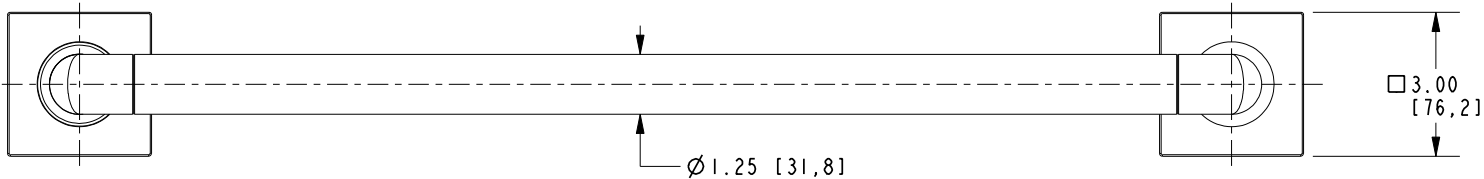

 MEETS OR EXCEEDS ASTM F446 STANDARDS AND CONFORMS TO ADA GUIDELINES.

BRASSTECH		2001 E. CARNEGIE AVE.
INCORPORATED		SANTA ANA, CA 92705
		(949) 417-5207
DWG NO.	3140-3924	REV -
SCALE .250	REF. -	SHEET 2 OF 2