

NOTES:

(NI) 1. FIT / FORM / FUNCTION SHALL FOLLOW PS-E.008.

BILL OF MATERIAL (CURRENT LEVEL)

ITEM	PT/ASSY	DESCRIPTION	TYPE	QTY.
1	5080SQ	12" GRAB BAR BRAZE ASM	ASSEMBLY	1
2	20-287	GRAB BAR MOUNTING HARDWARE PACK	ASSEMBLY	2
3	40679	DECORATIVE RING	PART	2
4	92308	SCRW, M5 X 5 SKT HD CUP PT SS	PART	2

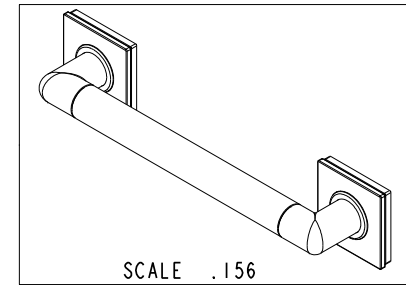
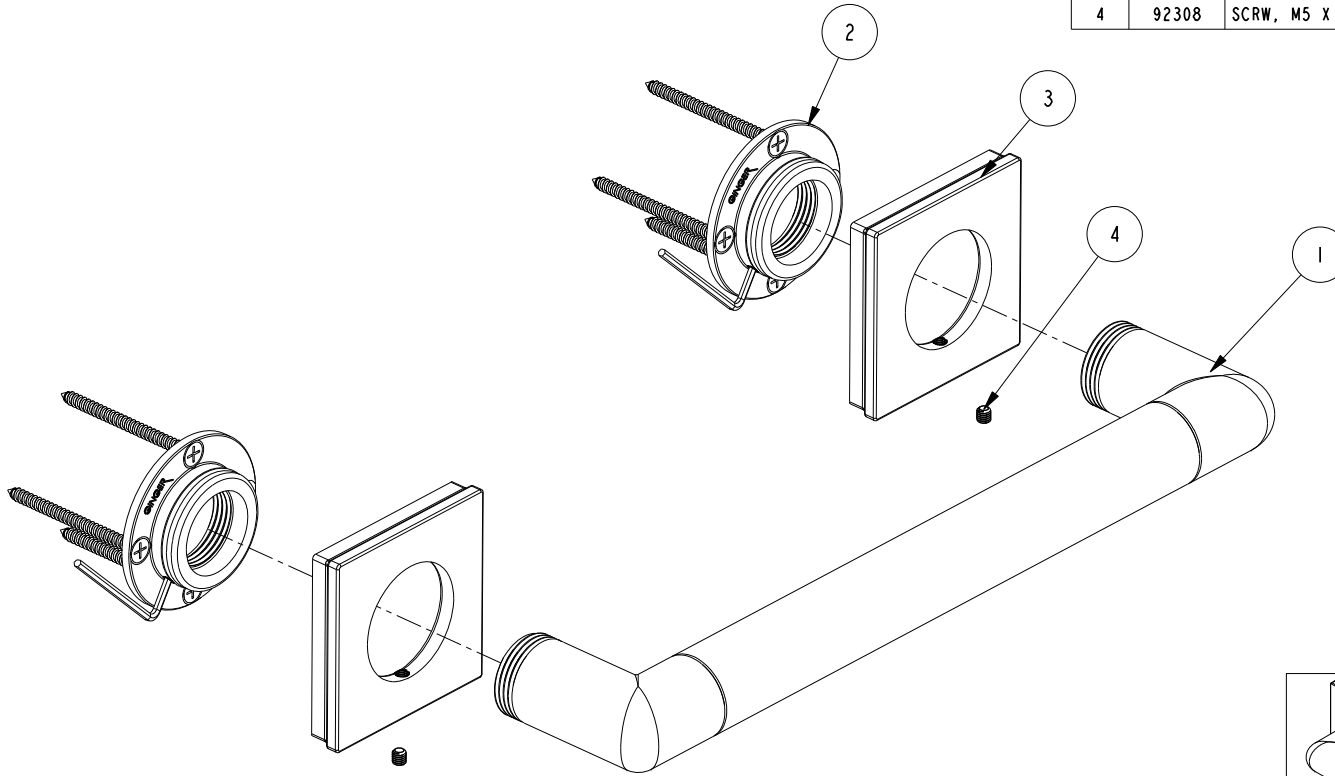

COPYRIGHT 2005 BRASSTECH, INC.
 THESE DRAWINGS AND THE DESIGNS
 DEPICTED HEREIN ARE THE PROPRIETARY
 PROPERTY OF BRASSTECH. ANY USE
 OR REPRODUCTION IS SUBJECT TO
 THE EXPRESS APPROVAL OF BRASSTECH.
 UNAUTHORIZED USE IS STRICTLY
 PROHIBITED. ALL RIGHTS RESERVED.

ZONE	REV	DESCRIPTION	DATE	APPROVED
-	-	EN-3279b	07/03/17	J.M.

TESTING	ASSEMBLY	PLATING	POLISHING	MACHINING	TOOLING FIXTURE #	APPLICATION
-	-	-	-	-	-	REMOVE ALL BURRS AND SHARP EDGES
-	-	-	-	-	NEXT ASSY	USED ON

UNITS ARE: INCHES [MM]	
TOLERANCES ARE:	
FRACTIONS DECIMALS	ANGLES
±1/16"	±1°
.X ±.1 [2.5]	
.XX ±.06 [1.5]	
(X.XXX) DENOTES CRITICAL DIMS.	
ALL THREADS ARE CRITICAL	
DRAWN	VINAY 04/10/17
CHECKED	RAVINDRA 04/10/17
APPROVED	J.M 04/10/17

BRASSTECH 2001 CARNEGIE AVE.
 INCORPORATED SANTA ANA, CA 92705
 (949) 417-5207

GRAB BAR 12"

DWG NO. 3140-3912 REV -

SCALE .375 REF. - SHEET 1 OF 2

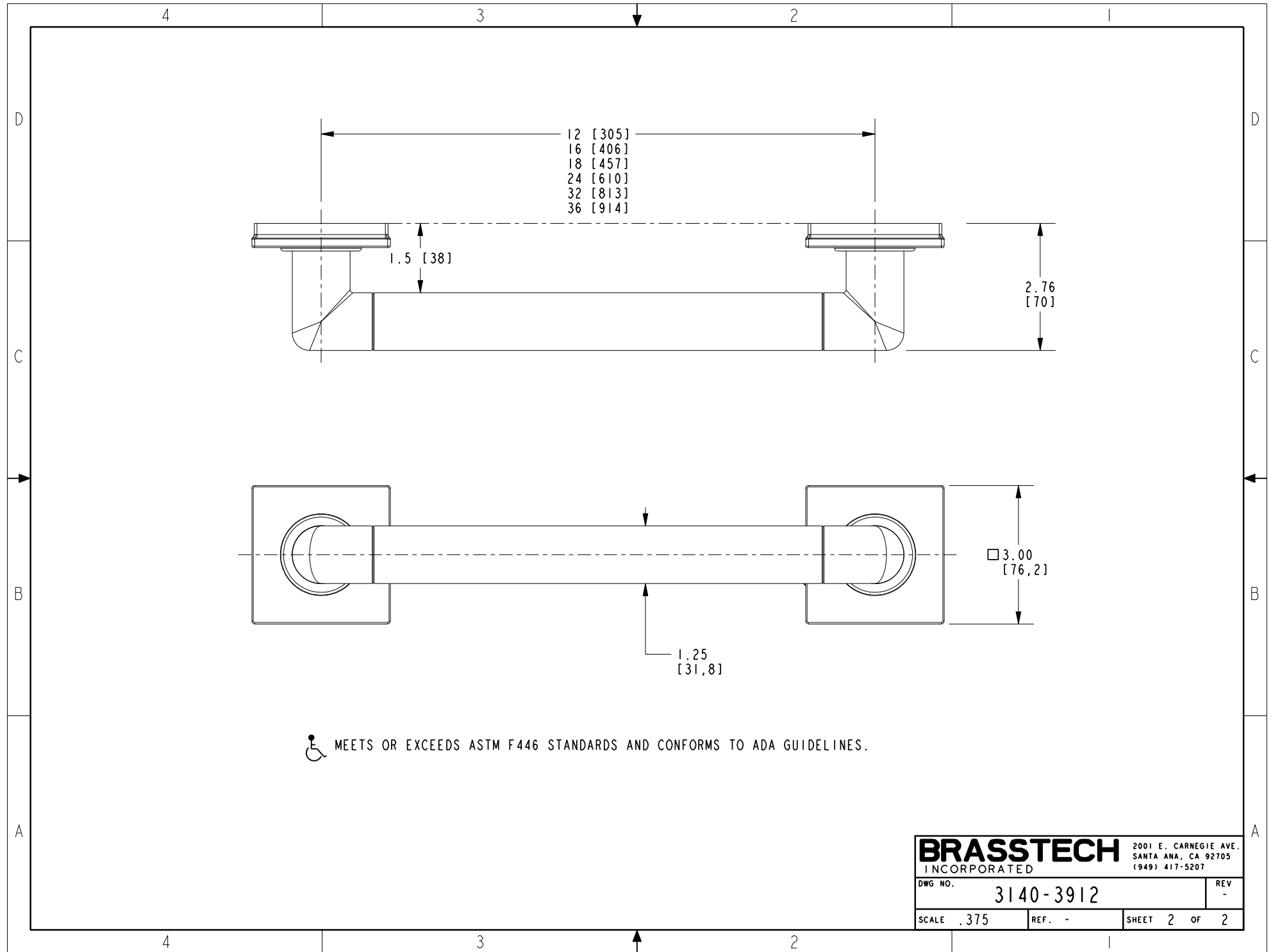

 MEETS OR EXCEEDS ASTM F446 STANDARDS AND CONFORMS TO ADA GUIDELINES.

BRASSTECH		2001 E. CARNEGIE AVE.
INCORPORATED		SANTA ANA, CA 92705
		(949) 417-5207
DWG NO.	3140-3912	REV -
SCALE .375	REF. -	SHEET 2 OF 2