

NOTES:

- (N1) 1. FIT / FORM / FUNCTION SHALL FOLLOW PS-E.008.
- 2. APPLY LIGHT FILM OF DOW 111 CORNING SILICONE GREASE.
- 3. ITEM 7 AS RECEIVED HAS NYLON PATCH. IF NYLON PATCH IS MISSING, APPLY ADHESIVE LOCTITE 242 APPROX. WHERE SHOWN.
- 4. WHEN TIGHTENING ITEM 7 DURING ASSEMBLY, APPLY 6-8 LB-IN OF TORQUE.
- (N5) 5. TORQUE REQUIRED TO ROTATE HANDLE AFTER ASSEMBLY SHOULD BE 15 +/-5 OZ-IN.
- 6. APPLY LOCTITE 680.
- 7. TORQUE 18-20 IN-LBS.

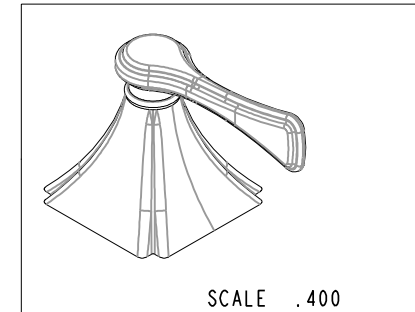
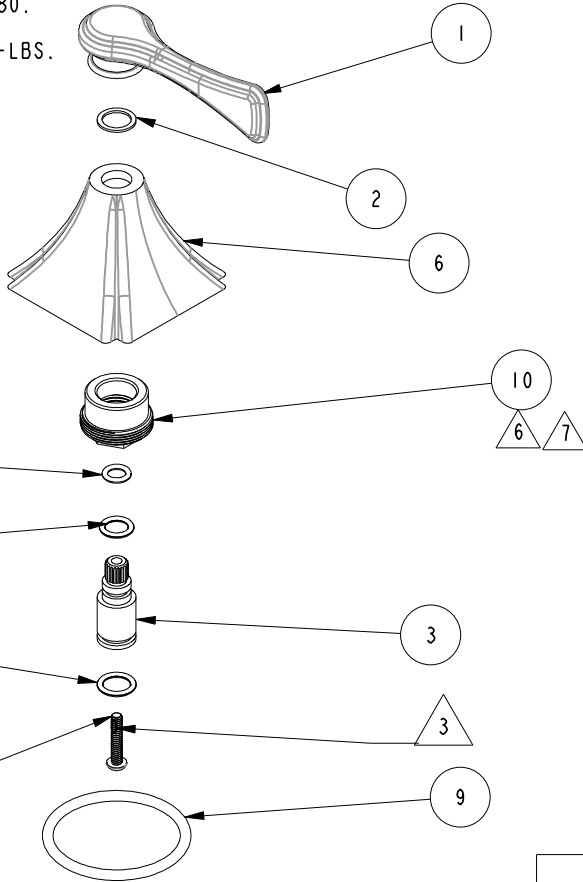

BILL OF MATERIAL (CURRENT LEVEL)				
ITEM	PT/ASSY	DESCRIPTION	TYPE	QTY.
1	11979	LEVER HANDLE - STRAIGHT	PART	1
2	91371	WASHER, HANDLE	PART	1
3	12506	HANDLE ADAPTER	PART	1
4	91049	O-RING, #2- 010, EPDM, 65-75 DURO, NSF 61	PART	1
5	91255	O-RING, #2- 011, EPDM, 65-75 DURO, NSF-61	PART	1
6	12313	HANDLE ESCUTCHEON	PART	1
7	92467	SCRW, 6-32 X 3/4" TORX BUTTON HD SS W/ NYLON PATCH	PART	1
8	91017	O-RING, #2- 012, EPDM, 65-75 DURO, NSF 61	PART	1
9	91570	O-RING, 3.5 X 42MM ID, EPDM, 65-75 DURO	PART	1
10	12861	ADAPTER BUSHING	PART	1

TESTING - - - ASSEMBLY - - - PLATING - - 3-2537 POLISHING - - NEXT ASSY USED ON MACHINING - - APPLICATION TOOLING FIXTURE # REMOVE ALL BURRS AND SHARP EDGES					UNITS ARE: INCHES [MM] TOLERANCES ARE: FRACTIONS DECIMALS ANGLES ±1/16" .X ±.1 [2,5] ±1" .XX ±.06 [1,5] (X.XXX) DENOTES CRITICAL DIMS. ALL THREADS ARE CRITICAL		BRASSTECH 2001 CARNEGIE AVE. INCORPORATED SANTA ANA, CA 92705 (949) 417-5207	
COPYRIGHT 2005 BRASSTECH, INC. THESE DRAWINGS AND THE DESIGNS DEPICTED HEREIN ARE THE PROPRIETARY PROPERTY OF BRASSTECH. ANY USE OR REPRODUCTION IS SUBJECT TO THE EXPRESS APPROVAL OF BRASSTECH. UNAUTHORIZED USE IS STRICTLY PROHIBITED. ALL RIGHTS RESERVED.					DRAWN J. AMOZOC 8/29/17 CHECKED V. VU 8/29/17 APPROVED V. VU 8/29/17		DWG NO. 3-606 REV -	
ZONE	REV	DESCRIPTION	DATE	APPROVED	SCALE .400	REF. -	SHEET OF	