

| | | | |
|------------------|-----------|--|---|
| BRASSTECH | | 2001 E. CARNEGIE AVE. SANTA ANA, CA 92705 (949) 417-5207 | |
| DWG NO. | 3210-5103 | REV | A |
| SCALE | .200 | REF. | - |
| SHEET 2 | | OF 3 | |

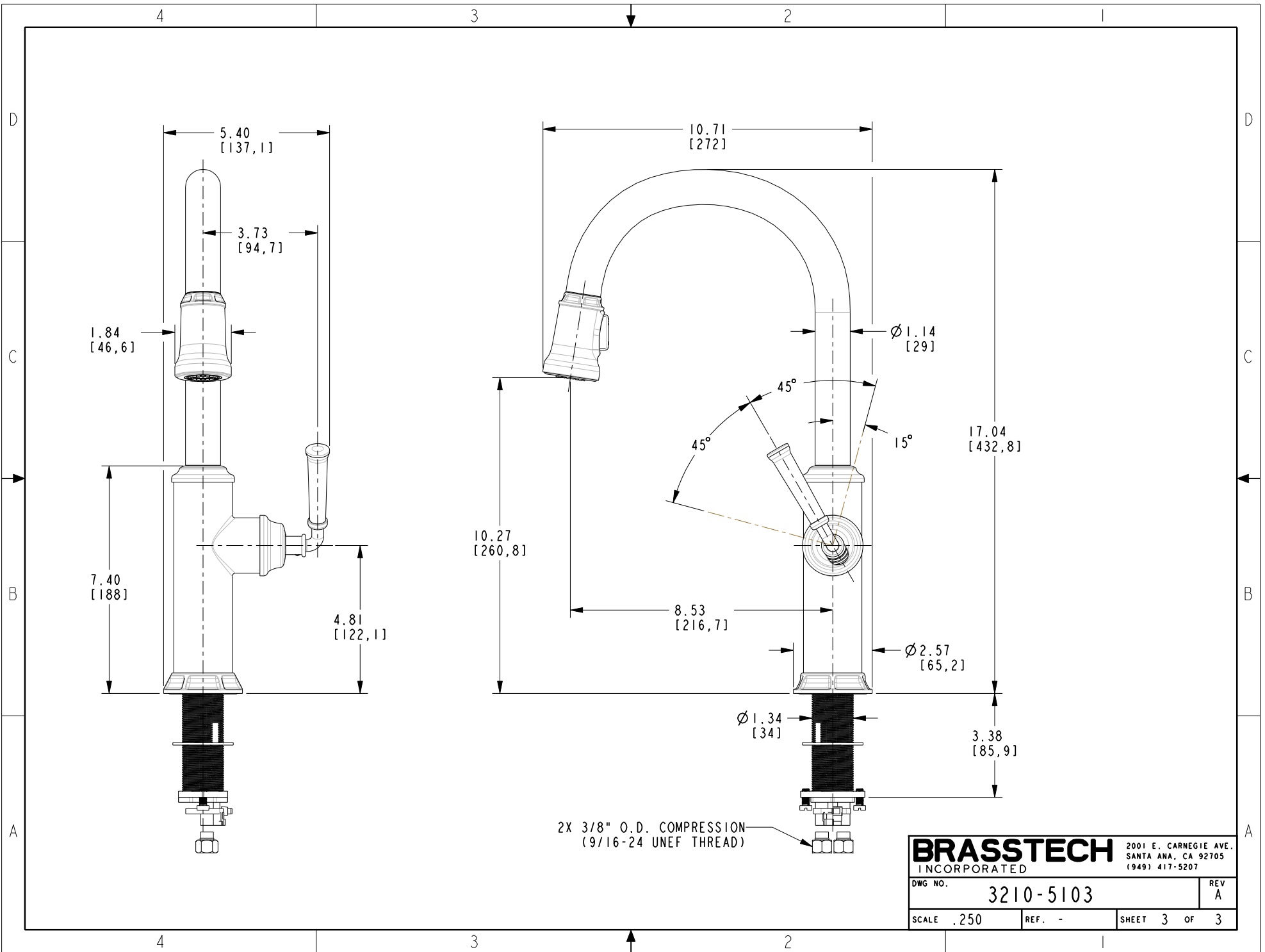

2X 3/8" O.D. COMPRESSION
(9/16-24 UNEF THREAD)

| | | | |
|------------------|-----------|--|---|
| BRASSTECH | | 2001 E. CARNEGIE AVE. SANTA ANA, CA 92705 (949) 417-5207 | |
| DWG NO. | 3210-5103 | REV | A |
| SCALE | .250 | REF. | - |
| SHEET 3 | | OF 3 | |