

NOTES:

(NI) 1. FIT / FORM / FUNCTION SHALL FOLLOW PS-E.008.

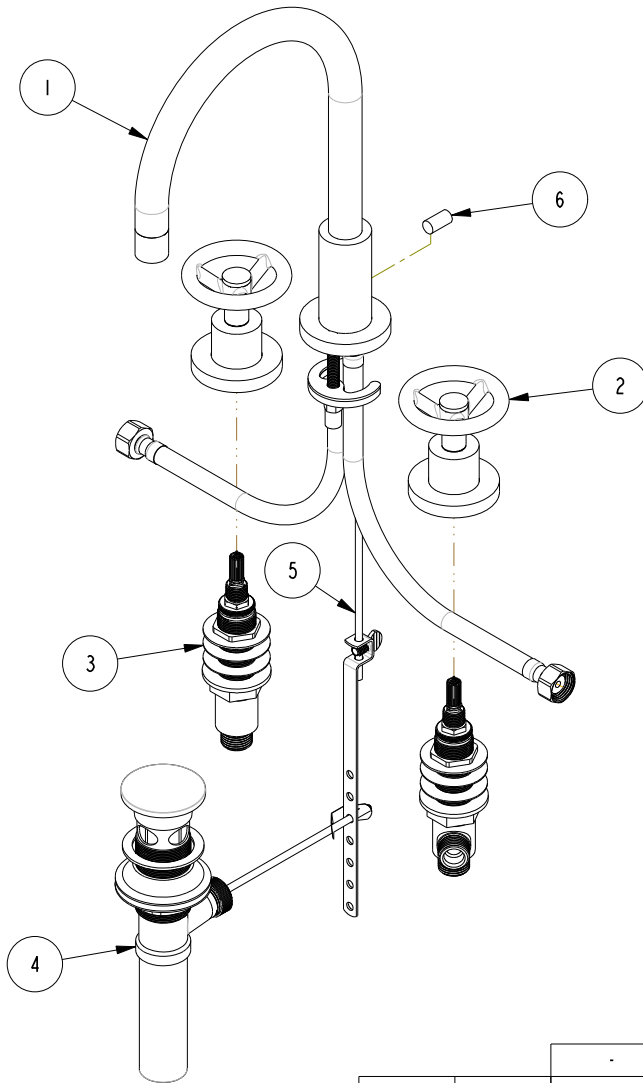

**BILL OF MATERIAL (CURRENT LEVEL)**

ITEM	PT/ASSY	DESCRIPTION	TYPE	QTY.
1	3-233	W/S SPOUT ASM	ASSEMBLY	1
2	3-570	HANDLE/ ESC ASM	ASSEMBLY	2
3	1-525	W/S VALVE ASM	ASSEMBLY	1
4	325	POP UP ASSEMBLY	ASSEMBLY	1
5	10288	3/16" POP UP ROD	PART	1
6	10827	POP-UP KNOB	PART	1

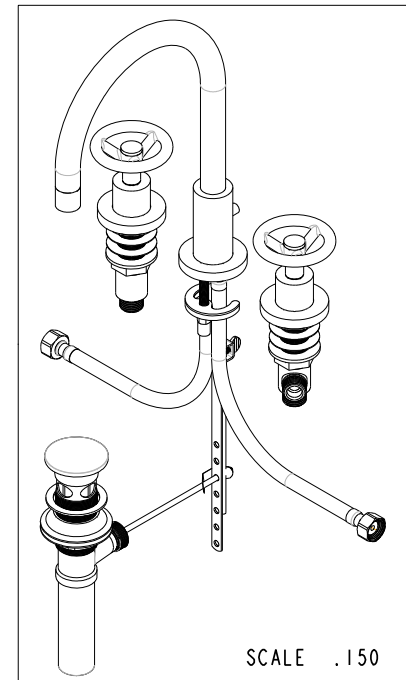

SCALE .150

ZONE	REV	DESCRIPTION	DATE	APPROVED
-	A	EN-3242	01/27/17	AN
-	-	EN-3005b	03/21/16	AN

COPYRIGHT 2005 BRASSTECH, INC. THESE DRAWINGS AND THE DESIGNS DEPICTED HEREIN ARE THE PROPRIETARY PROPERTY OF BRASSTECH. ANY USE OR REPRODUCTION IS SUBJECT TO THE EXPRESS APPROVAL OF BRASSTECH. UNAUTHORIZED USE IS STRICTLY PROHIBITED. ALL RIGHTS RESERVED.

TESTING	-	-	-
ASSEMBLY	-	-	-
PLATING	-	-	-
POLISHING	-	NEXT ASSY	USED ON
MACHINING	-	APPLICATION	
TOOLING FIXTURE #	REMOVE ALL BURRS AND SHARP EDGES		

UNITS ARE: INCHES [MM]	
TOLERANCES ARE:	
FRACTIONS	DECIMALS
±1/16"	.X ±.1 (2.5)
	.XX ±.06 (1.5)
(X.XXX) DENOTES CRITICAL DIMS.	
ALL THREADS ARE CRITICAL	
DRAWN	RAVINDRA 02/24/16
CHECKED	JINSON 02/24/16
APPROVED	AN 03/21/16

**BRASSTECH** 2001 CARNEGIE AVE.  
INCORPORATED SANTA ANA, CA 92705  
(949) 417-5207

W/S LAV FAUCET

DWG NO.	2920	REV	A
SCALE	.200	REF.	-
SHEET	1	OF	2

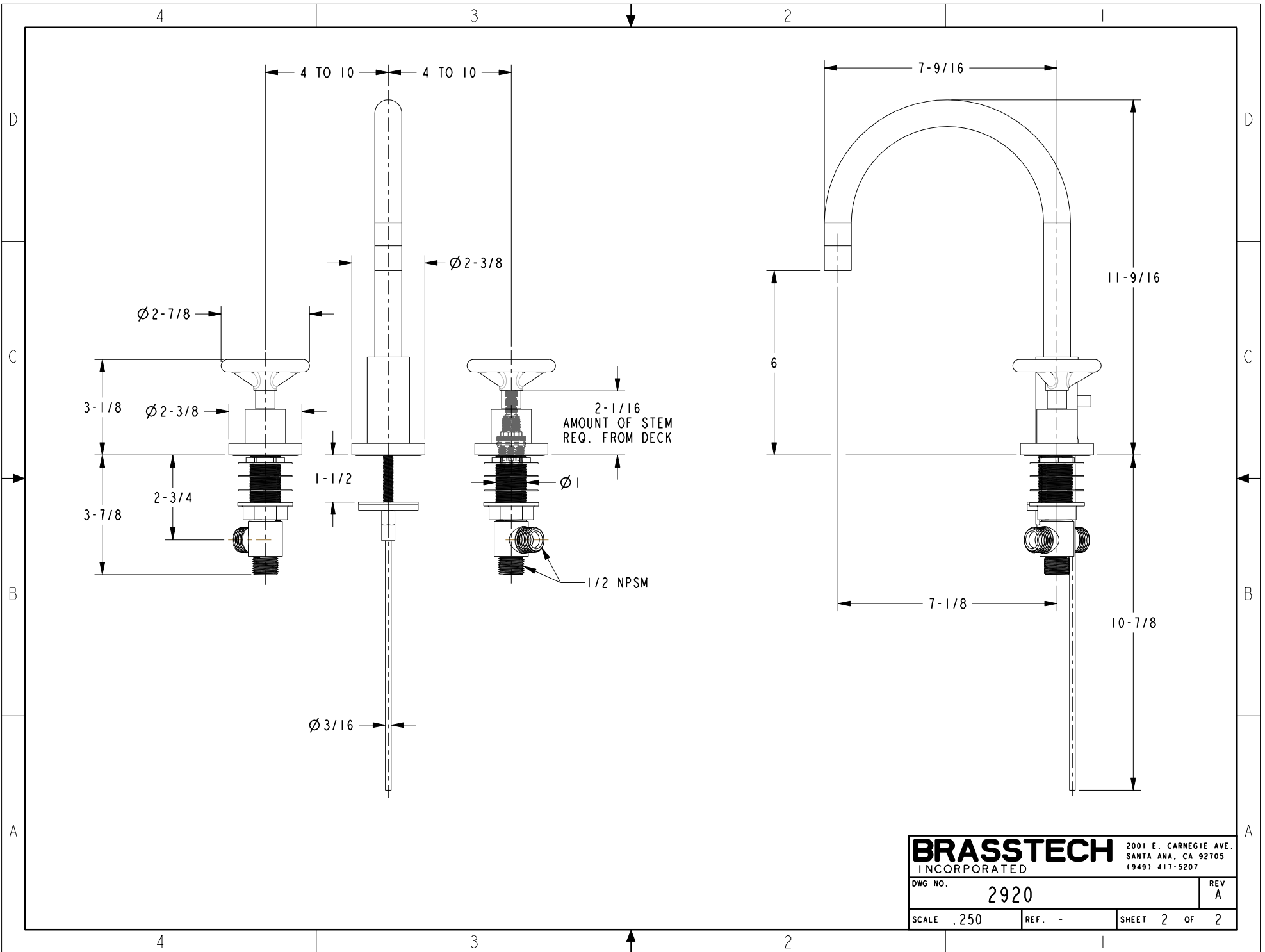

<b>BRASSTECH</b>		2001 E. CARNEGIE AVE. SANTA ANA, CA 92705 (949) 417-5207	
DWG NO.	2920	REV	A
SCALE	.250	REF.	-
		SHEET	2 OF 2