

NOTES:

(NI) 1. FIT / FORM / FUNCTION SHALL FOLLOW PS-E.008.

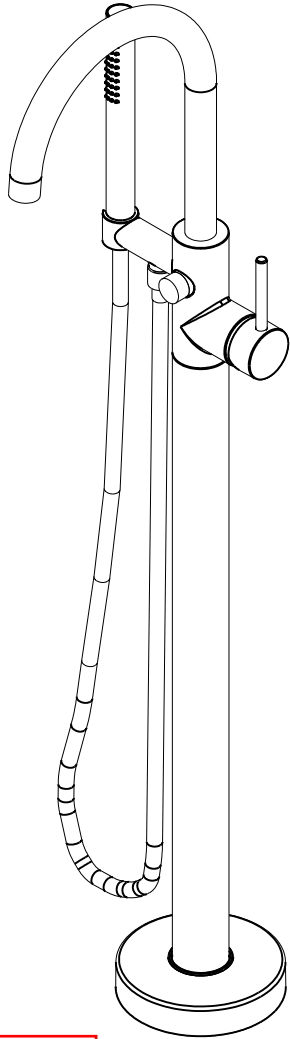

BILL OF MATERIAL (CURRENT LEVEL)

ITEM	PT/ASSY	DESCRIPTION	TYPE	QTY.
1	12187	BODY	PART	1
2	12189	ADAPTER	PART	1
3	91017	O-RING, #2- 012, EPDM, 65-75	DURDARNWSF	611
4	12175	HAND SHWR HOLDER	PART	1
5	92821	SCREW	PART	1
6	20-259	DIVERTER ASM	ASSEMBLY	1
7	1-292	CARTRIDGE	ASSEMBLY	1
8	12180	RETAINER CART. NUT	PART	1
9	12181	CAP, CARTRIDGE	PART	1
10	92035	SCRW, M4 X .7 X 10 PHL FLT HD	SSPART	1
11	12192	HANDLE HUB	PART	1
12	92308	SCRW, M5 X 5 SKT HD CUP PT SS	PART	2
13	12184	WATER SUPPLY HOSE	ASSEMBLY	2
14	20-310	BODY ASM	ASSEMBLY	1
15	10159	HEX KEY, 3/32 ALLOY STEEL	PART	1
16	283-101	ROUND WAND HANDSHOWER	ASSEMBLY	1
17	284	SHOWER HOSE	PART	1
18	3-460	BASE COVER ASM	ASSEMBLY	1
19	12193	HANDLE	PART	1
20	91049	O-RING, #2- 010, EPDM, 65-75	DURDARNWSF	611
21	12257	1/2 X 3/4 NPSM THD ADAPTER	PART	2
22	91649	AERATOR KEY	PART	1
23	20-260	DIVERTER ASM	ASSEMBLY	1
24	20-232	SPOUT ASM	ASSEMBLY	1
25	12191	DIVERTER BUTTON	PART	1
26	92070	SCRW, #14 X 2 SLT FLT HD SS	PART	3
27	91368	WALL ANCHOR PLASTIC, 12-1/4	PART	3

-FOR QC ISNPECTION OF PURCHASE UNITS SEE PAGE 5-8

ZONE	REV	DESCRIPTION	DATE	APPROVED
-	K	EN-3241	9/27/17	J.A.
-	J	EN-3209	12/01/16	V.V.
-	H	EN-2895	06/08/15	V.V.
-	G	EN-2866	03/30/15	V.V.

COPYRIGHT 2005 BRASSTECH, INC. THESE DRAWINGS AND THE DESIGNS DEPICTED HEREIN ARE THE PROPRIETARY PROPERTY OF BRASSTECH. ANY USE OR REPRODUCTION IS SUBJECT TO THE EXPRESS APPROVAL OF BRASSTECH. UNAUTHORIZED USE IS STRICTLY PROHIBITED. ALL RIGHTS RESERVED.

TESTING	-	-	-
ASSEMBLY	-	-	-
PLATING	-	-	-
POLISHING	-	-	-
MACHINING	-	-	-
TOOLING FIXTURE #	REMOVE ALL BURRS AND SHARP EDGES		

UNITS ARE: INCHES [MM]	
TOLERANCES ARE:	
FRACTIONS DECIMALS	ANGLES
±1/16"	±1°
.X ±.1 [2.5]	
.XX ±.06 [1.5]	
X.XXX DENOTES CRITICAL DIMS.	
ALL THREADS ARE CRITICAL	
DRAWN	H. LE 08/16/13
CHECKED	V. VU 08/16/13
APPROVED	V. VU 08/16/13

**BRASSTECH** 2001 CARNEGIE AVE. SANTA ANA, CA 92705 (949) 417-5207  
INCORPORATED

TUB FILLER, FREE STANDING-PRIYA

DWG NO. 2480-4261 REV K

SCALE .150 REF. - SHEET 1 OF 4

NOTES:

- 2. APPLY LOCTITE 680.
- 3. TORQUE TO 7.5-8.5 LB-FT.
- 4. APPLY LOCTITE 242. IF SCREW DOES NOT HAVE NYLON PATCH.
- 5. TORQUE TO 18-20 LB-IN.
- 6. PLACE THESE ITEMS IN SEPERATE PLASTIC BAGS
- 7. APPLY THIN COAT OF SILICON GREASE

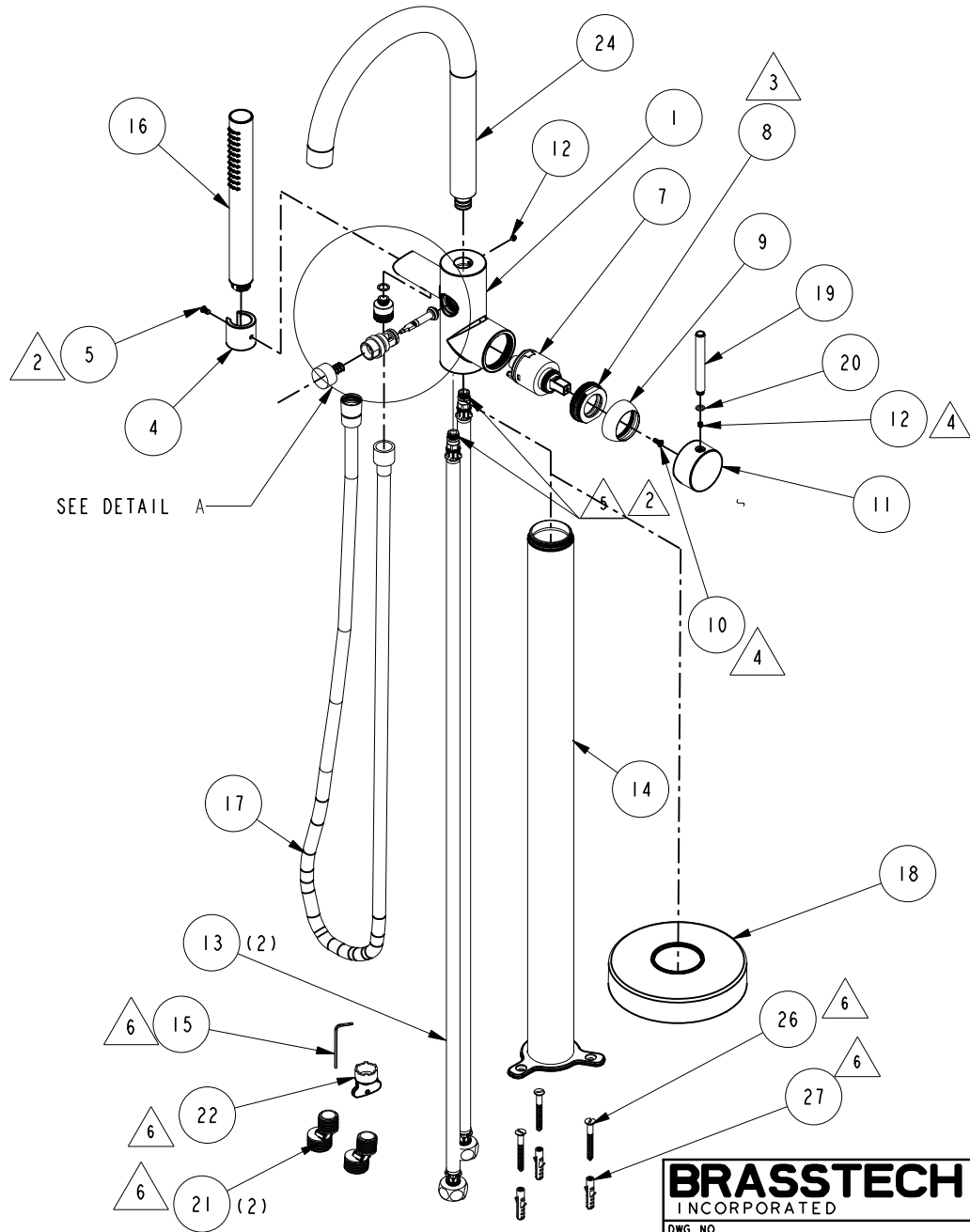

SEE DETAIL A

DETAIL A  
SCALE .325

<b>BRASSTECH</b> INCORPORATED		2001 E. CARNEGIE AVE. SANTA ANA, CA 92705 (949) 417-5207
DWG NO.	2480-4261	REV K
SCALE .140	REF. -	SHEET 2 OF 4

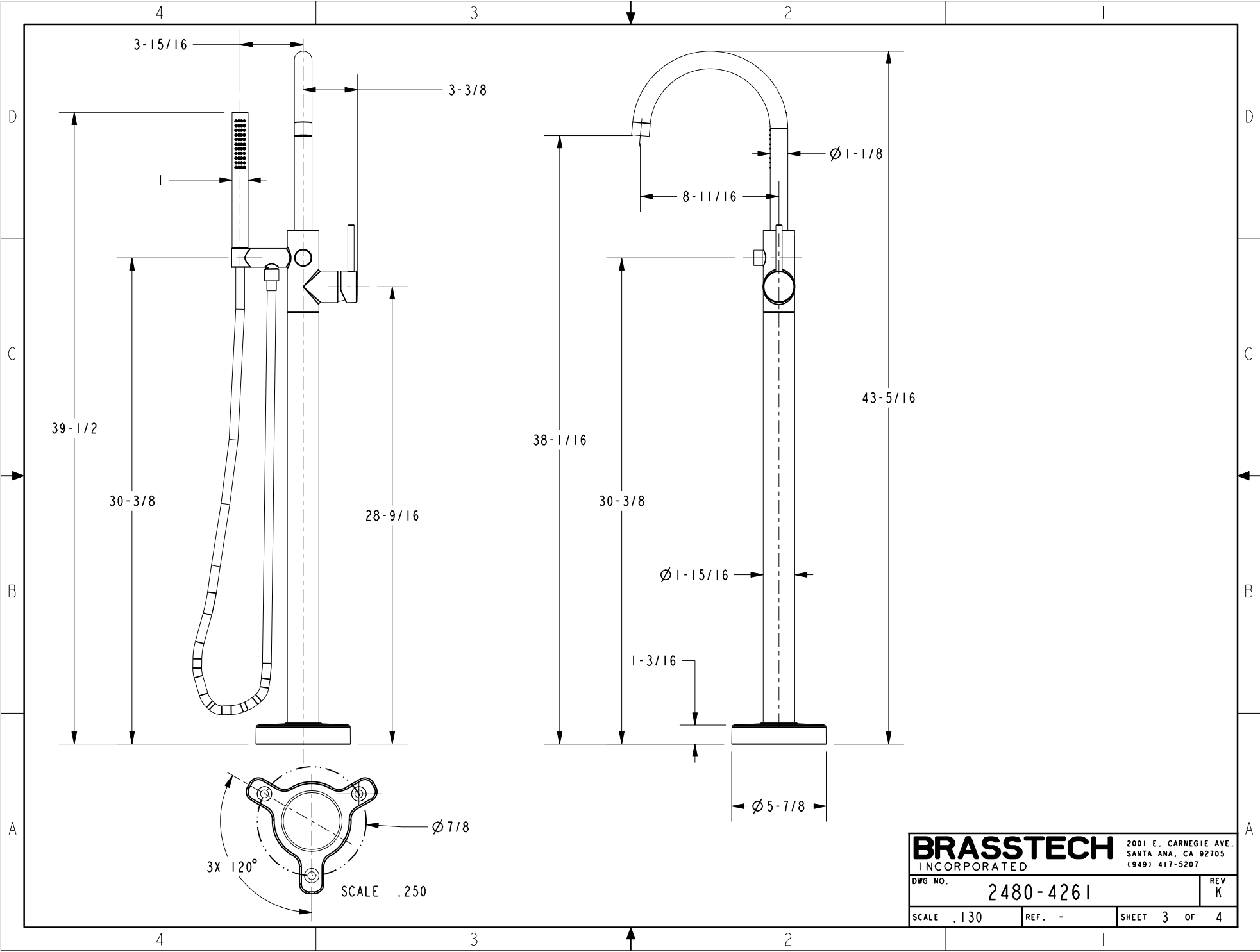

NOTES:

1.  $\longleftrightarrow$  INDICATES STROKE DIRECTION FOR SATIN FINISHES ONLY.

2.  $\triangle$  SAND BLAST THIS SURFACE.

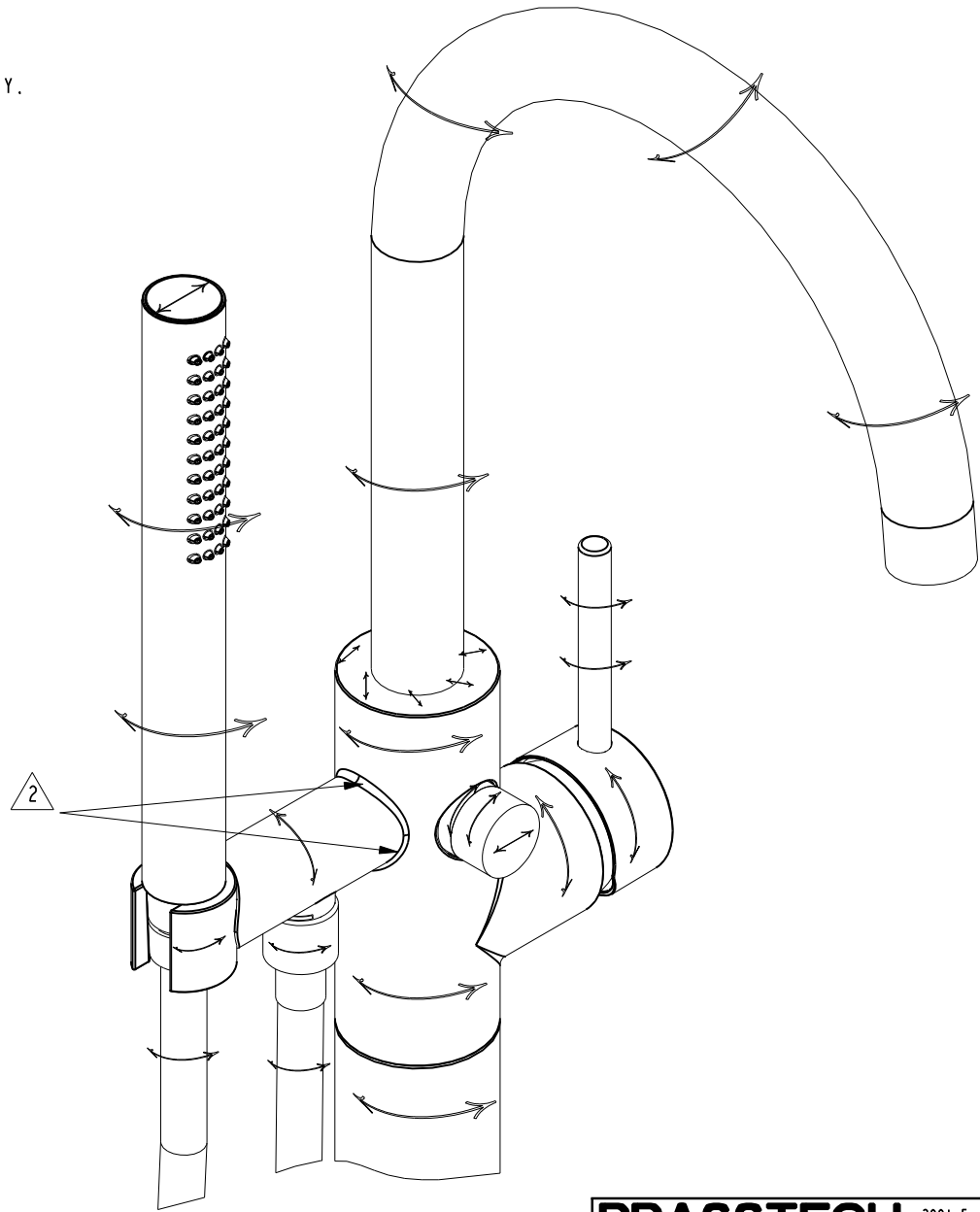
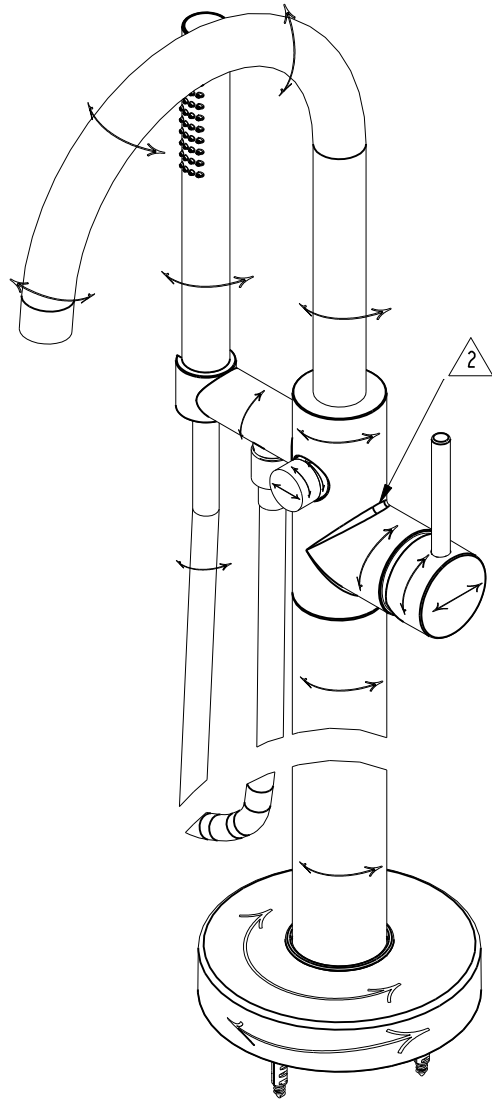

<b>BRASSTECH</b>		2001 E. CARNEGIE AVE.	
INCORPORATED		SANTA ANA, CA 92705	
DWG NO.		2480-4261	
SCALE .140		REV K	
REF. -		SHEET 4 OF 4	

NOTES:

- (NI) 1. FIT / FORM / FUNCTION SHALL FOLLOW PS-E.008.
- 2. APPLY LOCTITE 680.
- 3. APPLY LABEL 98045 ON THE BACK SIDE OF THE TUB FILLER.
- 4. APPLY LABEL 98136 ON THE BACK SIDE OF THE HAND SHOWER.
- 5. MARKING: "H C" (H ON TOP, C AT BOTTOM).
- 6. THIS HOSE CAN BE REPLACED WITH 284.

-FOR QC ISNPECTION ONLY  
-NOT FOR PRODUCTION

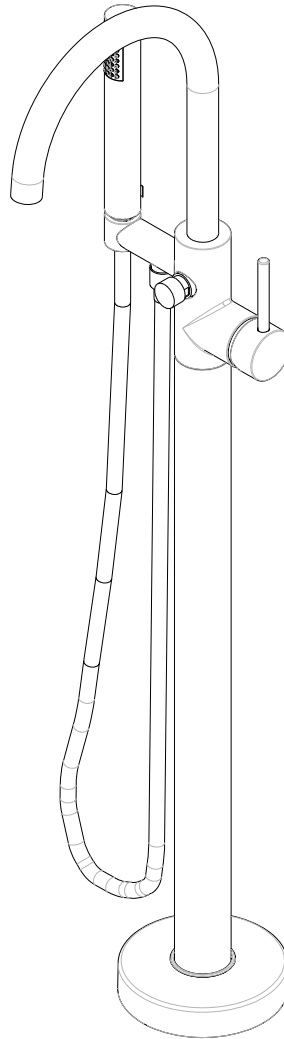

**BILL OF MATERIAL (CURRENT LEVEL)**

ITEM	PT/ASSY	DESCRIPTION	TYPE	QTY.
1	2-933	BODY	ASSEMBLY	1
2	12175	HAND SHWR HOLDER	PART	1
3	92821	SCREW	PART	1
4	2-914	DIVERTER ASM	ASSEMBLY	1
5	12191	DIVERTER BUTTON	PART	1
6	1-292	CARTRIDGE	ASSEMBLY	1
7	12180	RETAINER, CARTRIDGE	PART	1
8	12181	CAP, CARTRIDGE	PART	1
9	92825	SCREW, M4 x 0.7 x 10.5	PART	1
10	12192	HANDLE HUB	PART	1
11	92826	SET SCREW, M5 x 0.8 x 5	PART	2
12	12184	WATER SUPPLY HOSE	ASSEMBLY	2
13	3-454	BODY ASM	ASSEMBLY	1
14	92830	HEX KEY	PART	1
15	3-459	HAND SHOWER ASM	ASSEMBLY	1
16	12186	SHOWER HOSE	PART	1
17	1-293	MOUNTING SCREW SET	ASSEMBLY	1
18	3-460	BASE COVER ASM	ASSEMBLY	1
19	12193	HANDLE	PART	1
20	91629	O-RING	PART	1
21	12257	1/2 X 3/4 NPSM THD ADAPTER	PART	2
22	91649	AERATOR KEY	PART	1
23	98045	LABEL	PART	1
24	98136	LABEL	PART	1
25	20-232	SPOUT ASM	ASSEMBLY	1

TESTING	-	-	-
ASSEMBLY	-	-	-
PLATING	-	-	-
POLISHING	-	NEXT ASSY	USED ON
MACHINING	-	APPLICATION	
TOOLING	FIXTURE #	REMOVE ALL BURRS AND SHARP EDGES	

UNITS ARE: INCHES [MM]  
TOLERANCES ARE:  
FRACTIONS DECIMALS ANGLES  
±1/16" .X ±.1 [2.5] ±1°  
.XX ±.06 [1.5]  
X.XXX DENOTES CRITICAL DIMS.  
ALL THREADS ARE CRITICAL

**BRASSTECH** 2001 CARNEGIE AVE.  
INCORPORATED SANTA ANA, CA 92705  
(949) 417-5207

TUB FILLER, FREE STANDING-PRIYA

-	J	EN-3209	12/01/16	V.V.	COPYRIGHT 2005 BRASSTECH, INC. THESE DRAWINGS AND THE DESIGNS DEPICTED HEREIN ARE THE PROPRIETARY PROPERTY OF BRASSTECH. ANY USE OR REPRODUCTION IS SUBJECT TO THE EXPRESS APPROVAL OF BRASSTECH. UNAUTHORIZED USE IS STRICTLY PROHIBITED. ALL RIGHTS RESERVED.
-	H	EN-2895	06/08/15	V.V.	
-	G	EN-2866	03/30/15	V.V.	
ZONE	REV	DESCRIPTION	DATE	APPROVED	

DWG NO.	2480-4261	REV	J
SCALE	.150	REF.	-
SHEET	1	OF	4

-FOR QC ISNPECTION ONLY  
 -NOT FOR PRODUCTION

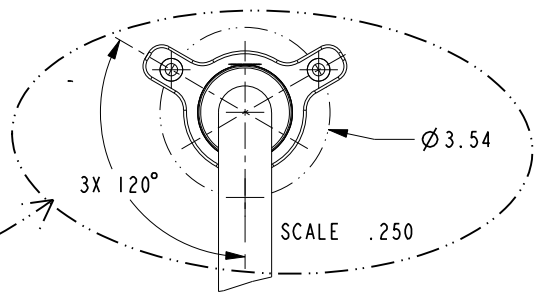
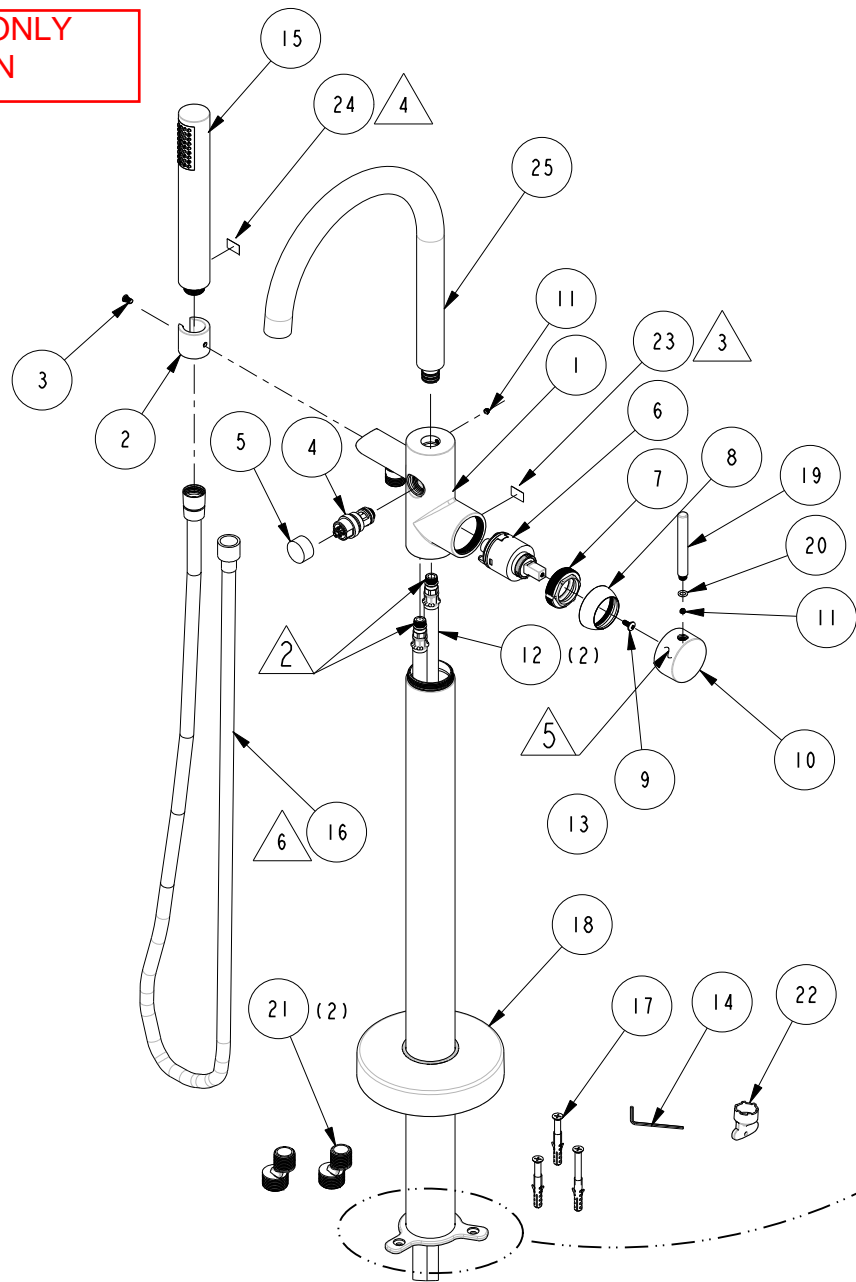

<b>BRASSTECH</b> INCORPORATED		2001 E. CARNEGIE AVE. SANTA ANA, CA 92705 (949) 417-5207
DWG NO.	2480-4261	REV J
SCALE .140	REF. -	SHEET 2 OF 4

-FOR QC ISNPECTION ONLY  
-NOT FOR PRODUCTION

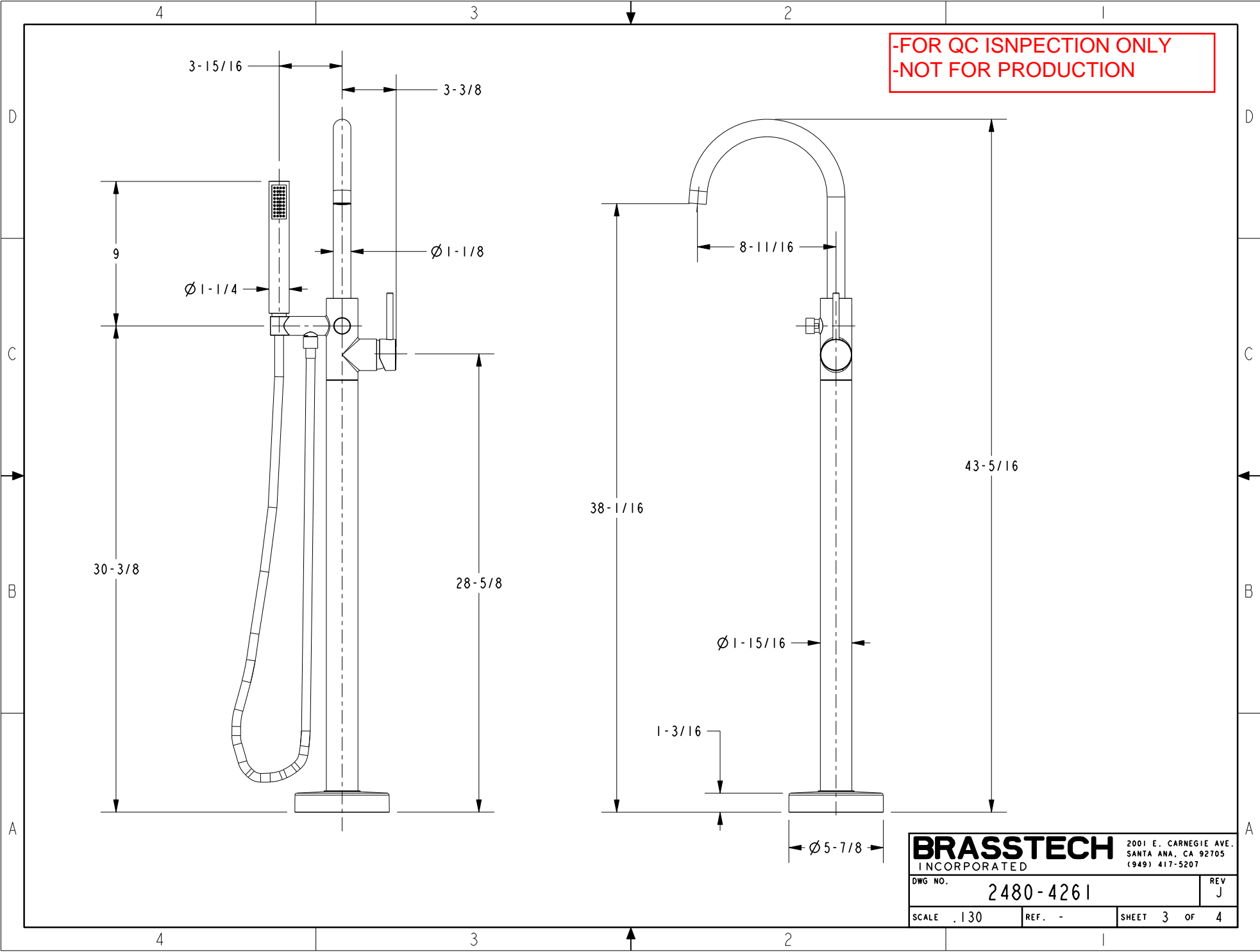

<b>BRASSTECH</b> INCORPORATED		2001 E. CARNEGIE AVE. SANTA ANA, CA 92705 (949) 417-5207
DWG NO.	2480-4261	REV J
SCALE .130	REF. -	SHEET 3 OF 4

**-FOR QC ISNPECTION ONLY  
-NOT FOR PRODUCTION**

NOTES:

1.  $\longleftrightarrow$  INDICATES STROKE DIRECTION FOR SATIN FINISHES ONLY.

2.  $\triangle$  SAND BLAST THIS SURFACE.

D  
C  
B  
A

D  
C  
B  
A

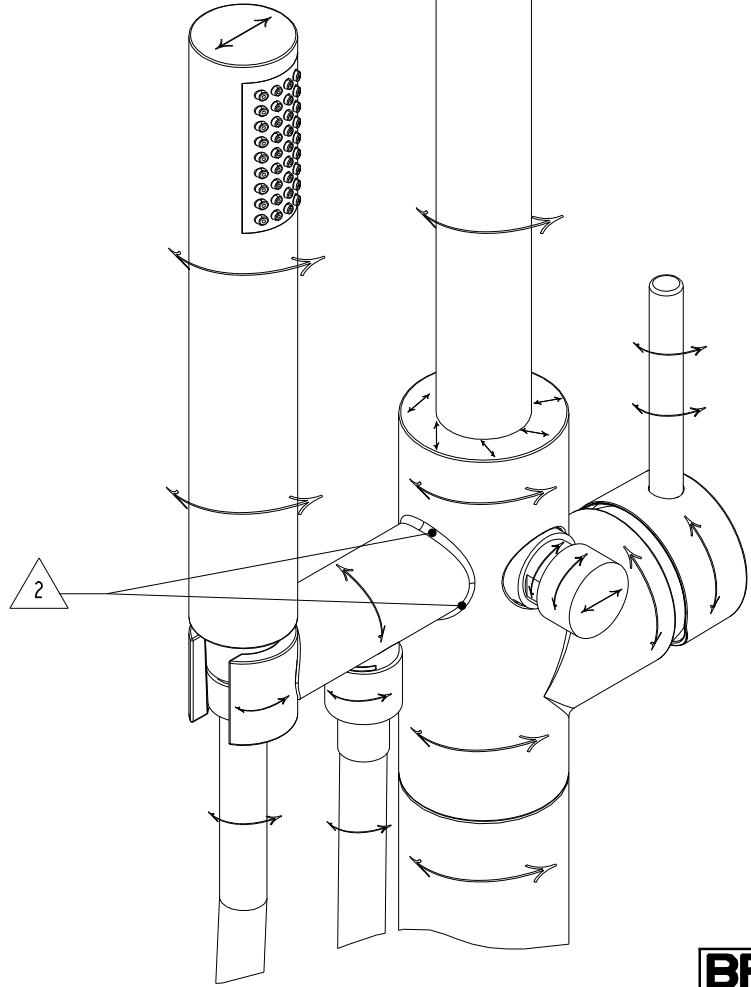
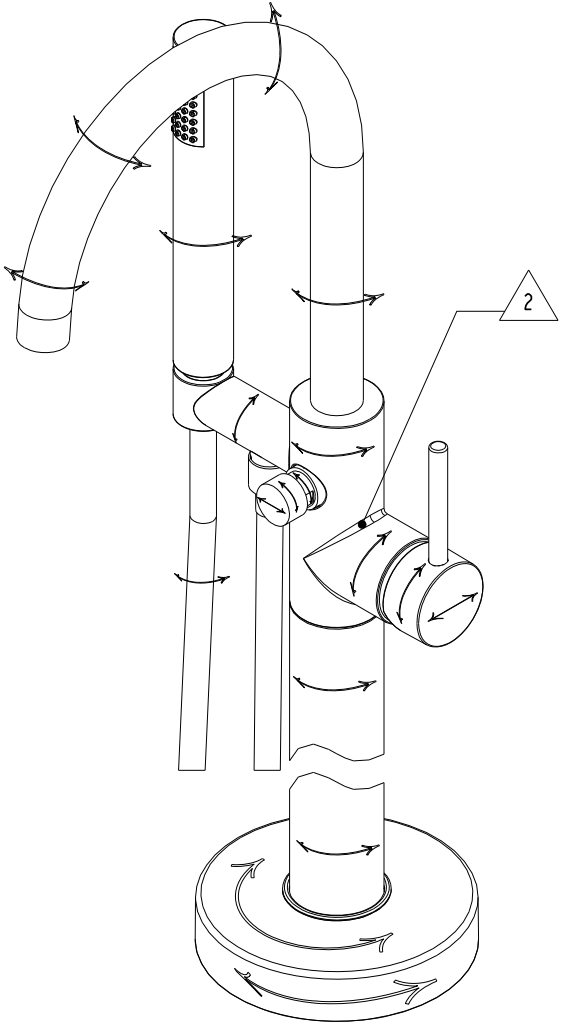

2

4

3

2

<b>BRASSTECH</b>		2001 E. CARNEGIE AVE. SANTA ANA, CA 92705 (949) 417-5207	
DWG NO.	2480-4261	REV	J
SCALE	.140	REF.	-
		SHEET	4 OF 4