

NOTES:

1. FIT / FORM / FUNCTION SHALL FOLLOW PS-E.008.

2 APPLY LOCTITE 680 TO THREADS

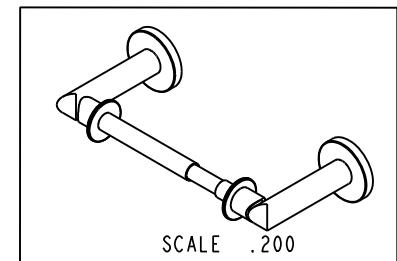
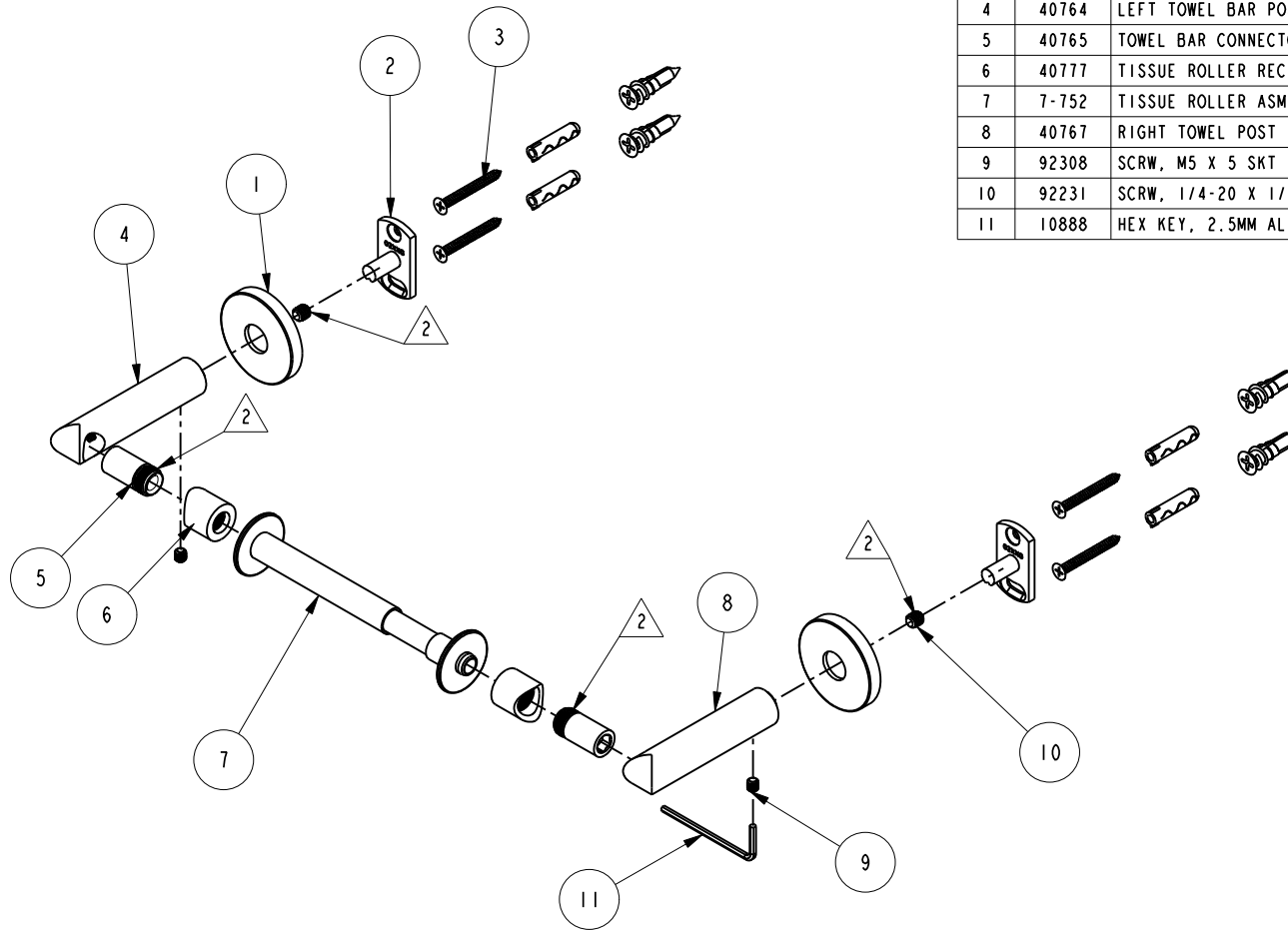

| BILL OF MATERIAL (CURRENT LEVEL) | | | | |
|----------------------------------|---------|---|----------|------|
| ITEM | PT/ASSY | DESCRIPTION | TYPE | QTY. |
| 1 | 40458 | ROSETTE | PART | 2 |
| 2 | 02XXG | MOUNTING BRACKET | PART | 2 |
| 3 | 1-206 | HARDWARE PACK | ASSEMBLY | 2 |
| 4 | 40764 | LEFT TOWEL BAR POST | PART | 1 |
| 5 | 40765 | TOWEL BAR CONNECTOR | PART | 2 |
| 6 | 40777 | TISSUE ROLLER RECEIVER | PART | 2 |
| 7 | 7-752 | TISSUE ROLLER ASM | ASSEMBLY | 1 |
| 8 | 40767 | RIGHT TOWEL POST | PART | 1 |
| 9 | 92308 | SCRW, M5 X 5 SKT HD CUP PT W/ SELF LOC SS | PART | 2 |
| 10 | 92231 | SCRW, 1/4-20 X 1/4 SKT HD CUP PT SS | PART | 2 |
| 11 | 10888 | HEX KEY, 2.5MM ALLOY STEEL | PART | 1 |

| | | | | | | | | | | | | | | | | | | | | | | | | | | | | | | | | | | | | | | |
|---|---|----------------------------------|----------|------|---|------|------------------------------|------------|--------------|----------|---|---|---|---|---------|---|---|---|---|-----------|---|-----------|---------|--|-----------|---|-------------|--|--|-------------------|--|----------------------------------|--|--|--|--|---|--|
| <table border="1"> <tr> <td>TESTING</td> <td>-</td> <td>-</td> <td>-</td> <td>-</td> </tr> <tr> <td>ASSEMBLY</td> <td>-</td> <td>-</td> <td>-</td> <td>-</td> </tr> <tr> <td>PLATING</td> <td>-</td> <td>-</td> <td>-</td> <td>-</td> </tr> <tr> <td>POLISHING</td> <td>-</td> <td>NEXT ASSY</td> <td>USED ON</td> <td></td> </tr> <tr> <td>MACHINING</td> <td>-</td> <td colspan="2">APPLICATION</td> <td></td> </tr> <tr> <td>TOOLING FIXTURE #</td> <td></td> <td colspan="2">REMOVE ALL BURRS AND SHARP EDGES</td> <td></td> </tr> </table> | | | | | TESTING | - | - | - | - | ASSEMBLY | - | - | - | - | PLATING | - | - | - | - | POLISHING | - | NEXT ASSY | USED ON | | MACHINING | - | APPLICATION | | | TOOLING FIXTURE # | | REMOVE ALL BURRS AND SHARP EDGES | | | UNITS ARE: INCHES [MM] TOLERANCES ARE: FRACTIONS DECIMALS ANGLES $\pm 1/16"$.X $\pm .1$ [2.5] $\pm 1^\circ$.XX $\pm .06$ [1.5] | | BRASSTECH INCORPORATED 2001 CARNEGIE AVE. SANTA ANA, CA 92705 (949) 417-5207 | |
| TESTING | - | - | - | - | | | | | | | | | | | | | | | | | | | | | | | | | | | | | | | | | | |
| ASSEMBLY | - | - | - | - | | | | | | | | | | | | | | | | | | | | | | | | | | | | | | | | | | |
| PLATING | - | - | - | - | | | | | | | | | | | | | | | | | | | | | | | | | | | | | | | | | | |
| POLISHING | - | NEXT ASSY | USED ON | | | | | | | | | | | | | | | | | | | | | | | | | | | | | | | | | | | |
| MACHINING | - | APPLICATION | | | | | | | | | | | | | | | | | | | | | | | | | | | | | | | | | | | | |
| TOOLING FIXTURE # | | REMOVE ALL BURRS AND SHARP EDGES | | | | | | | | | | | | | | | | | | | | | | | | | | | | | | | | | | | | |
| COPYRIGHT 2005 BRASSTECH, INC. THESE DRAWINGS AND THE DESIGNS DEPICTED HEREIN ARE THE PROPRIETARY PROPERTY OF BRASSTECH. ANY USE OR REPRODUCTION IS SUBJECT TO THE EXPRESS APPROVAL OF BRASSTECH. UNAUTHORIZED USE IS STRICTLY PROHIBITED. ALL RIGHTS RESERVED. | | | | | (X.XXX) DENOTES CRITICAL DIMS. ALL THREADS ARE CRITICAL | | DOUBLE POST TP HOLDER | | | | | | | | | | | | | | | | | | | | | | | | | | | | | | | |
| - | B | EN-4109 | 02/18/20 | J.M. | DRAWN | G.B. | 07/17/19 | DWG NO. | REV | | | | | | | | | | | | | | | | | | | | | | | | | | | | | |
| - | A | EN-4022 | 11/11/19 | J.M. | CHECKED | J.M. | 07/17/19 | 990-1500 | B | | | | | | | | | | | | | | | | | | | | | | | | | | | | | |
| - | - | EN-3910 | 07/17/19 | J.M. | APPROVED | J.M. | 07/17/19 | SCALE .300 | SHEET 1 OF 2 | | | | | | | | | | | | | | | | | | | | | | | | | | | | | |

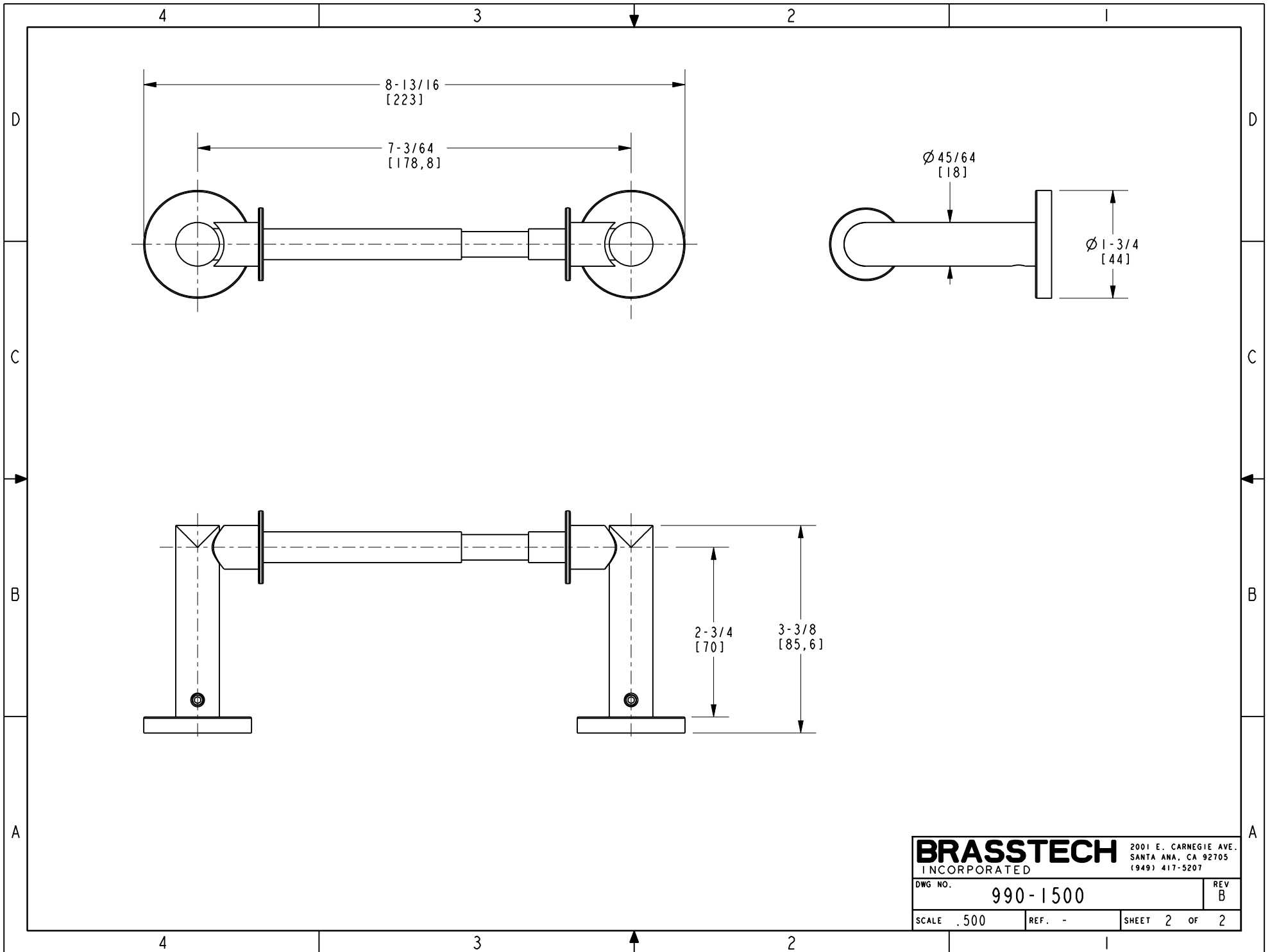

| | | | |
|------------------|----------|--|------|
| BRASSTECH | | 2001 E. CARNEGIE AVE. SANTA ANA, CA 92705 (949) 417-5207 | |
| DWG NO. | 990-1500 | REV | B |
| SCALE .500 | REF. - | SHEET 2 | OF 2 |