

NOTES:

(NI) 1. FIT / FORM / FUNCTION SHALL FOLLOW PS-E.008.

BILL OF MATERIAL (CURRENT LEVEL)

ITEM	PT/ASSY	DESCRIPTION	TYPE	QTY.
1	12649	ESCUTCHEON	PART	1
2	50688	AIR GAP CAP	PART	1
3	91772	O-RING, # 2-131, EP, 50 DURO - GREY	PART	1
4	20-244	AIR GAP ADAPTER ASM	ASSEMBLY	1

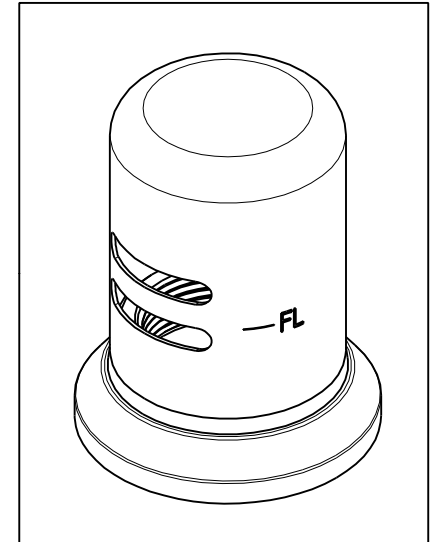
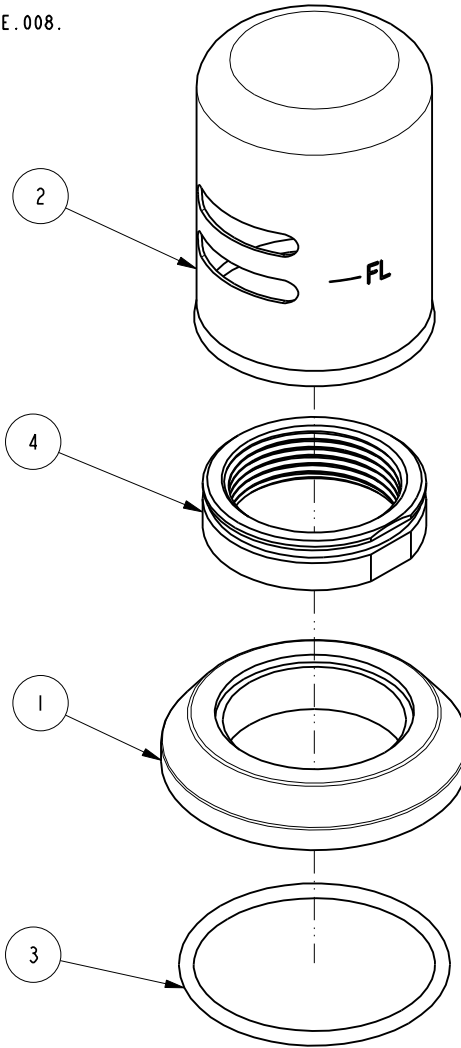

ZONE	REV	DESCRIPTION	DATE	APPROVED
-	A	EN-3722	02/08/19	C.G.
-	-	EN-3076	03/14/17	J.M

COPYRIGHT 2005 BRASSTECH, INC. THESE DRAWINGS AND THE DESIGNS DEPICTED HEREIN ARE THE PROPRIETARY PROPERTY OF BRASSTECH. ANY USE OR REPRODUCTION IS SUBJECT TO THE EXPRESS APPROVAL OF BRASSTECH. UNAUTHORIZED USE IS STRICTLY PROHIBITED. ALL RIGHTS RESERVED.

TESTING	ASSEMBLY	PLATING	POLISHING	MACHINING	TOOLING FIXTURE #
-	-	-	-	-	-
-	-	3200-5503	3200-5503	-	-
-	-	NEXT ASSY	USED ON	-	-
-	-	APPLICATION		-	-
-	-	REMOVE ALL BURRS AND SHARP EDGES		-	-

UNITS ARE: INCHES [MM]		
TOLERANCES ARE:		
FRACTIONS	DECIMALS	ANGLES
±1/16"	.X ±.1 [2.5]	±1°
	.XX ±.06 [1.5]	
(X.XXX) DENOTES CRITICAL DIMS. ALL THREADS ARE CRITICAL		
DRAWN	JINSON	02/08/19
CHECKED	C.G.	02/08/19
APPROVED	C.G.	02/08/19

BRASSTECH 2001 CARNEGIE AVE.
INCORPORATED SANTA ANA, CA 92705
(949) 417-5207

AIR CAP ASM

DWG NO.	3200-5751	REV	A
SCALE	.750	REF.	-
SHEET	1	OF	2

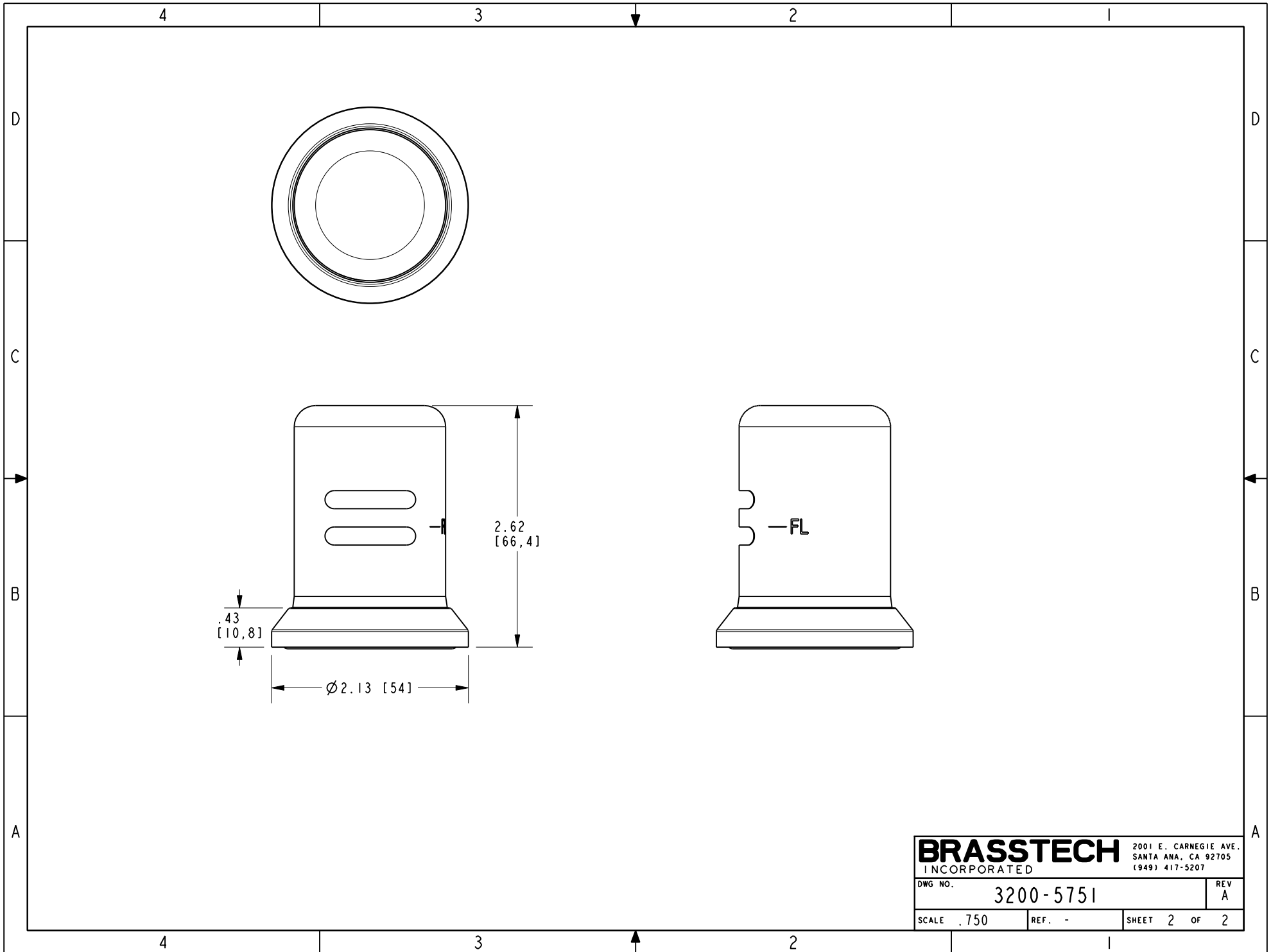

BRASSTECH		2001 E. CARNEGIE AVE. SANTA ANA, CA 92705 (949) 417-5207	
DWG NO.	3200-5751	REV	A
SCALE	.750	REF.	-
SHEET 2		OF 2	