

NOTES:

(NI) 1. FIT / FORM / FUNCTION SHALL FOLLOW PS-E.008.

BILL OF MATERIAL (CURRENT LEVEL)

ITEM	PT/ASSY	DESCRIPTION	TYPE	QTY.
1	2-100	ESCUTCHEON - ASSEMBLY	ASSEMBLY	1
2	10620	BONNET	PART	1
3	20-143	HANDLE ASM	ASSEMBLY	1
4	92141	SCREW, CAP HD 1/4-20 X 1/2	PART	1
5	92846	HEX KEY, 3/16" ALLOY STEEL	PART	1

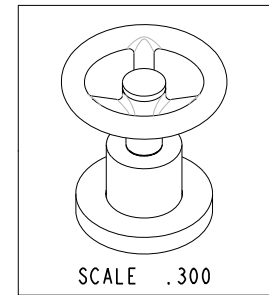
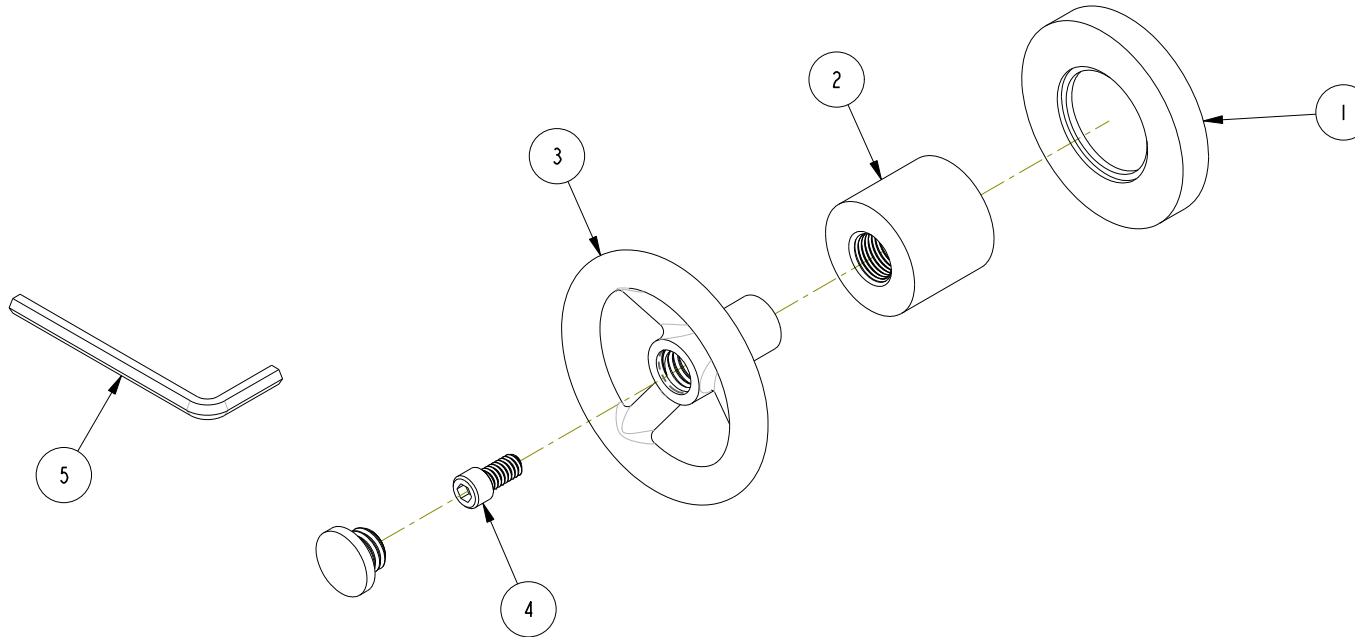

ZONE	REV	DESCRIPTION	DATE	APPROVED
-	A	EN-3242	01/27/17	AN
-	-	EN-3005	02/10/16	AN

COPYRIGHT 2005 BRASSTECH, INC. THESE DRAWINGS AND THE DESIGNS DEPICTED HEREIN ARE THE PROPRIETARY PROPERTY OF BRASSTECH. ANY USE OR REPRODUCTION IS SUBJECT TO THE EXPRESS APPROVAL OF BRASSTECH. UNAUTHORIZED USE IS STRICTLY PROHIBITED. ALL RIGHTS RESERVED.

TESTING	-	-	-
ASSEMBLY	-	-	-
PLATING	-	-	2920, 2950
POLISHING	-	NEXT ASSY	USED ON
MACHINING	-	APPLICATION	
TOOLING FIXTURE #	REMOVE ALL BURRS AND SHARP EDGES		

UNITS ARE: INCHES [MM]		
TOLERANCES ARE:		
FRACTIONS	DECIMALS	ANGLES
±1/16"	.X ±.1 (2.5)	±1°
	.XX ±.06 (1.5)	
(X.XXX) DENOTES CRITICAL DIMS.		
ALL THREADS ARE CRITICAL		
DRAWN	AN	02/05/16
CHECKED	AN	02/10/16
APPROVED	AN	02/10/16

BRASSTECH 2001 CARNEGIE AVE.
INCORPORATED SANTA ANA, CA 92705
(949) 417-5207

HANDLE/ ESC ASM

DWG NO. **3-570** REV **A**

SCALE .500 REF. - SHEET | OF |