

NOTES:

(N1) 1. FIT / FORM / FUNCTION SHALL FOLLOW PS-E.008.

BILL OF MATERIAL (CURRENT LEVEL)

ITEM	PT/ASSY	DESCRIPTION	TYPE	QTY.
1	1-331	THERMO WALL PLATE ASM	ASSEMBLY	1
2	12120	THERMO PLATE	PART	1
3	11029	SLEEVE - THERMO	PART	1
4	20-176	THERMO BONNET ASM	ASSEMBLY	1
5	91308	TEMP LIMIT STOP - THERMO	PART	1
6	92113	SCRW, M4 X .7 X 40 PHL FLT HD SS	PART	1
7	20-187	LEVER HANDLE ASSEMBLY	ASSEMBLY	1

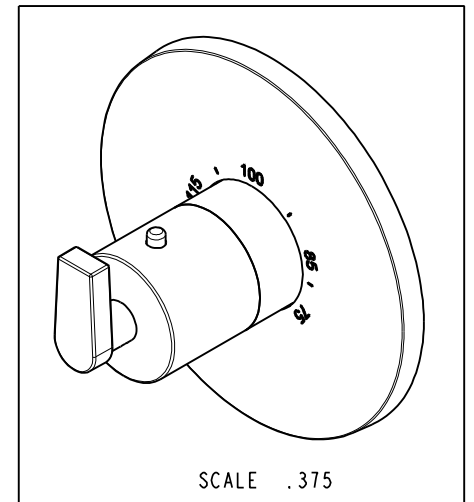
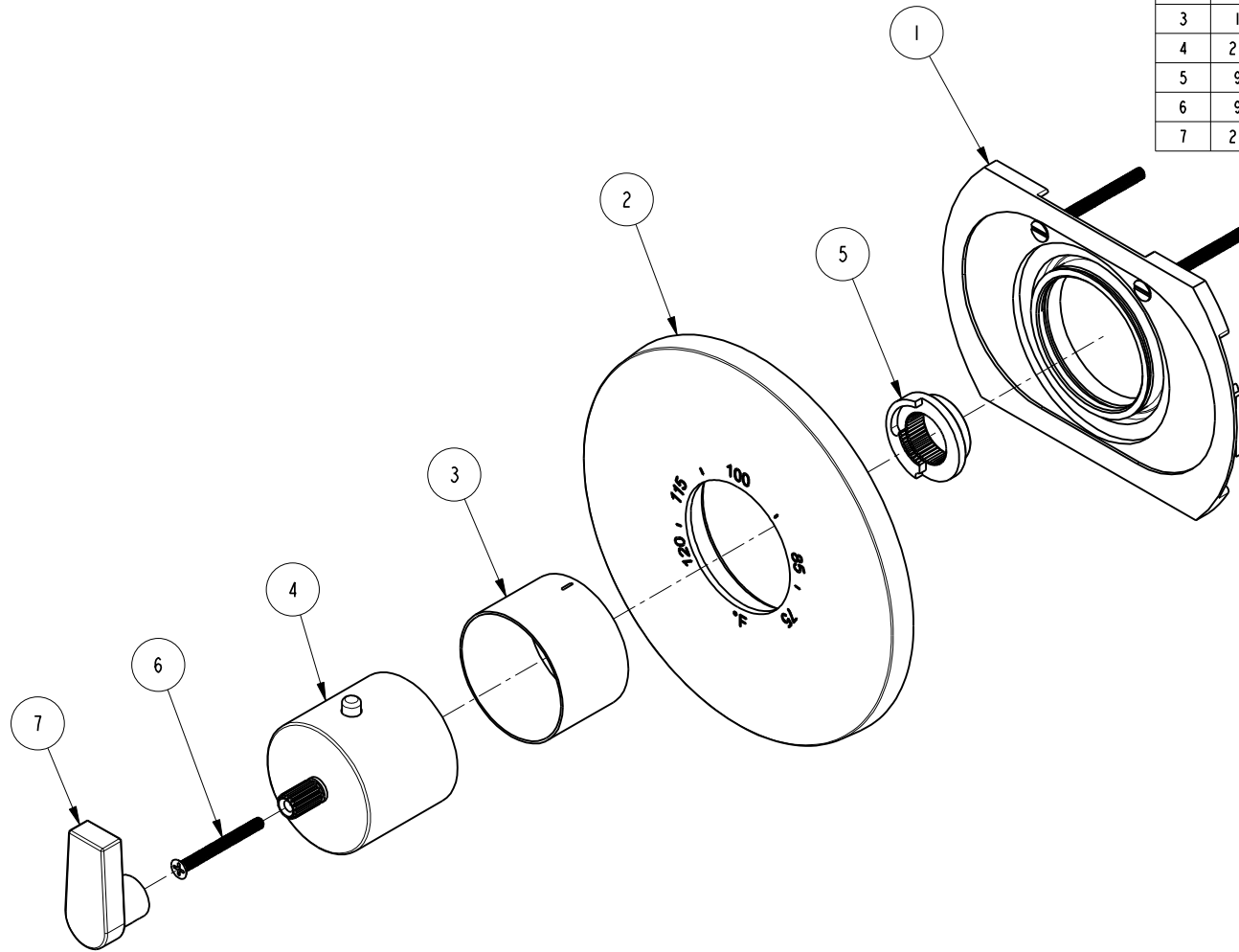

UNITS ARE: INCHES [MM]  
 TOLERANCES ARE:  
 FRACTIONS DECIMALS ANGLES  
 ±1/16" .X ±.1 [2.5] ±1°  
 .XX ±.06 [1.5]  
 (X.XXX) DENOTES CRITICAL DIMS.  
 ALL THREADS ARE CRITICAL  
 DRAWN AMARISH 08/03/16  
 CHECKED RAVINDRA 08/03/16  
 APPROVED J.M 08/03/16

**BRASSTECH** 2001 CARNEGIE AVE.  
 INCORPORATED SANTA ANA, CA 92705  
 (949) 417-5207

3/4" THERMOSTATIC TRIM

DWG NO. 3-2974TR REV -

SCALE .400 REF. - SHEET 1 OF 3

COPYRIGHT 2005 BRASSTECH, INC.  
 THESE DRAWINGS AND THE DESIGNS  
 DEPICTED HEREIN ARE THE PROPRIETARY  
 PROPERTY OF BRASSTECH. ANY USE  
 OR REPRODUCTION IS SUBJECT TO  
 THE EXPRESS APPROVAL OF BRASSTECH.  
 UNAUTHORIZED USE IS STRICTLY  
 PROHIBITED. ALL RIGHTS RESERVED.

TESTING	-	-	-
ASSEMBLY	-	-	-
PLATING	-	-	-
POLISHING	-	NEXT ASSY	USED ON
MACHINING	-	APPLICATION	
TOOLING FIXTURE #	REMOVE ALL BURRS AND SHARP EDGES		

ZONE	REV	DESCRIPTION	DATE	APPROVED
-	-	EN-3041	08/03/16	J.M

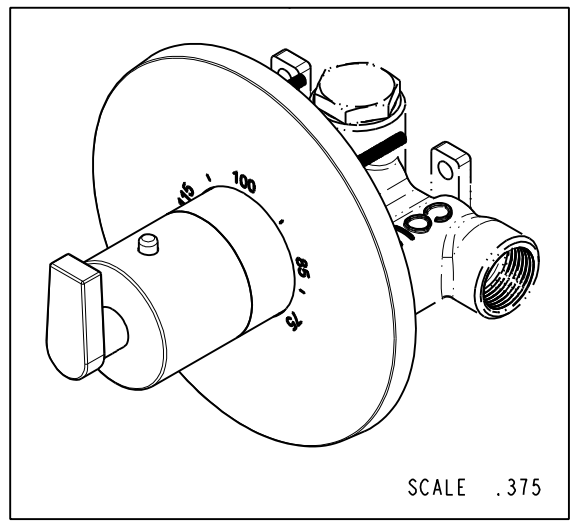
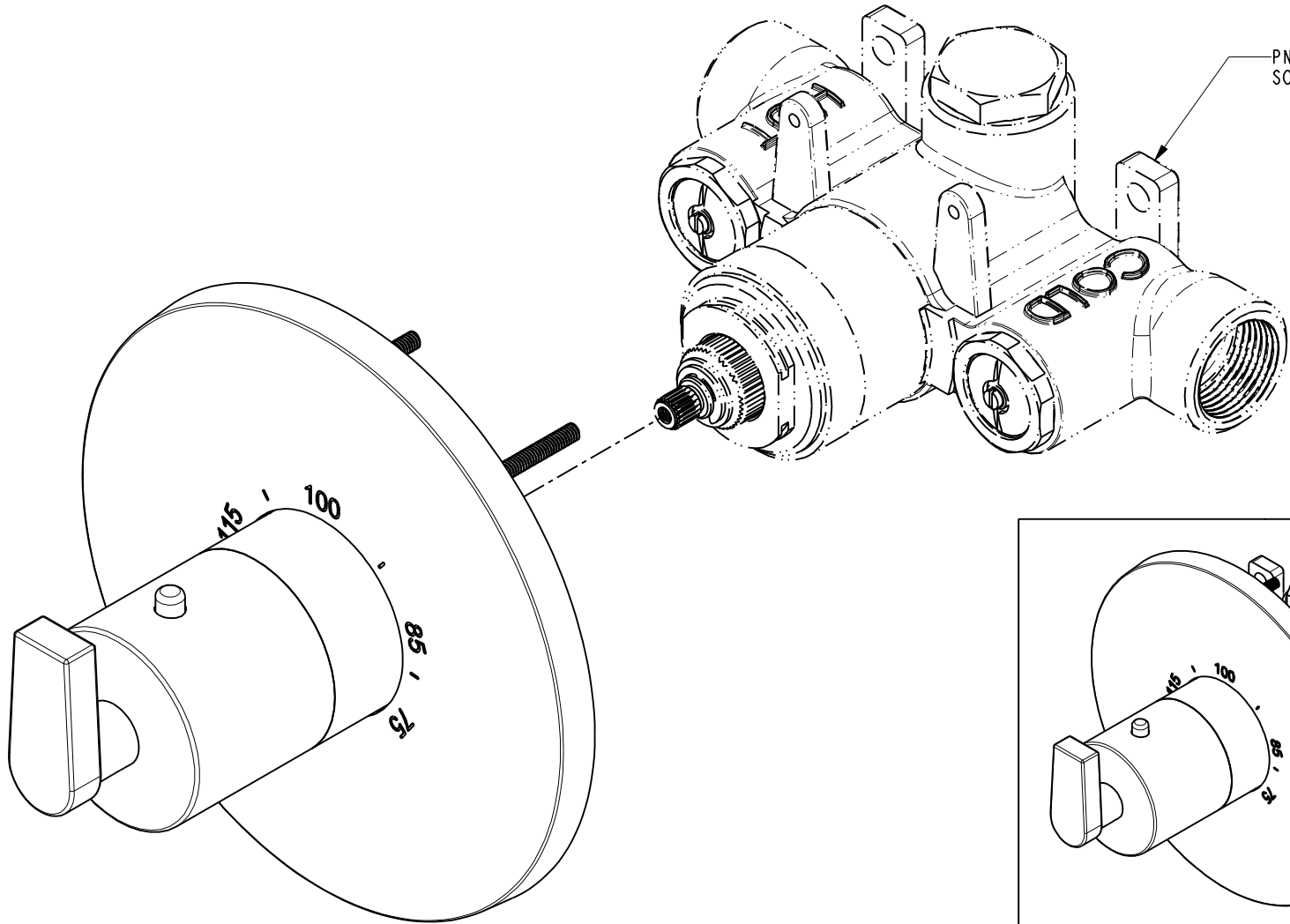

<b>BRASSTECH</b>		2001 E. CARNEGIE AVE.	
INCORPORATED		SANTA ANA, CA 92705	
		(949) 417-5207	
DWG NO.	3-2974TR		REV
			-
SCALE .675	REF. -	SHEET 2	OF 3

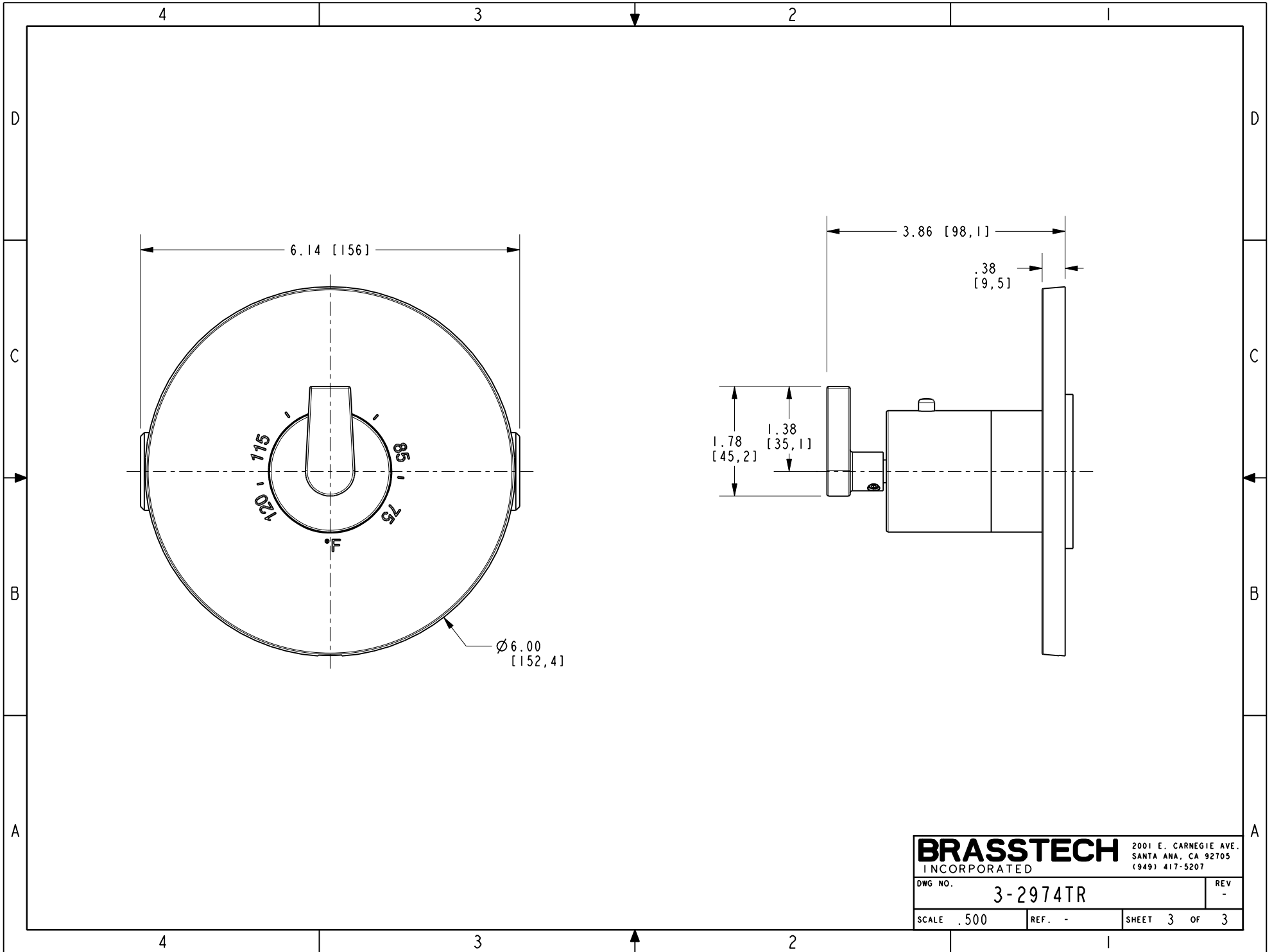

<b>BRASSTECH</b>		2001 E. CARNEGIE AVE.	
INCORPORATED		SANTA ANA, CA 92705	
DWG NO. 3-2974TR		REV -	
SCALE .500	REF. -	SHEET 3 OF 3	