

NOTES:

1. TO INSPECT ASSEMBLY, FOLLOW FIRST ARTICLE AND IN PROCESS INSPECTION SHEET.
2. SEAL NUT 10259 IN A PLASTIC BAG AND TAPE TO THE BACK OF THE TRIM PLATE.

**BILL OF MATERIAL (CURRENT LEVEL)**

ITEM	PT/ASSY	DESCRIPTION	TYPE	QTY.
1	206	SHOWER ARM FLANGE	PART	1
2	200	SHOWER ARM 6" BRASS	PART	1
3	2156	SHOWER HEAD, TRAD	ASSEMBLY	1
4	2-225	BP COVER PLATE FOR SHOWER	ASSEMBLY	1
5	10960	HEX ESCUTCHEON	PART	1
6	2-279	TAPERED LEVER HNDL ASM	ASSEMBLY	1
7	91754	O-RING, #2-034, EPDM, 50 DURO - GREY	PART	1
8	10259	HEX NUT 9/16 X 20 MADE	PART	1

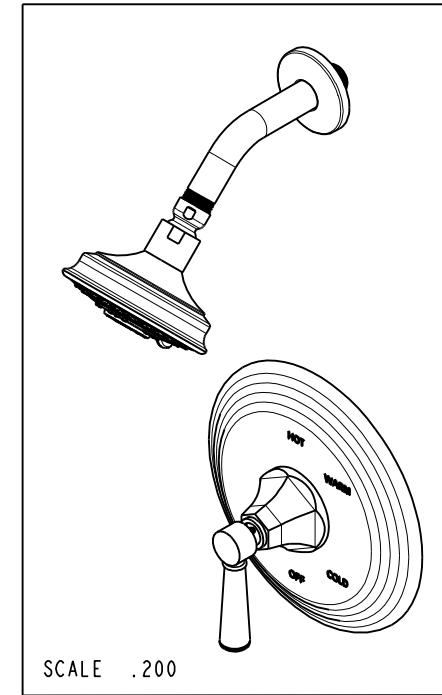
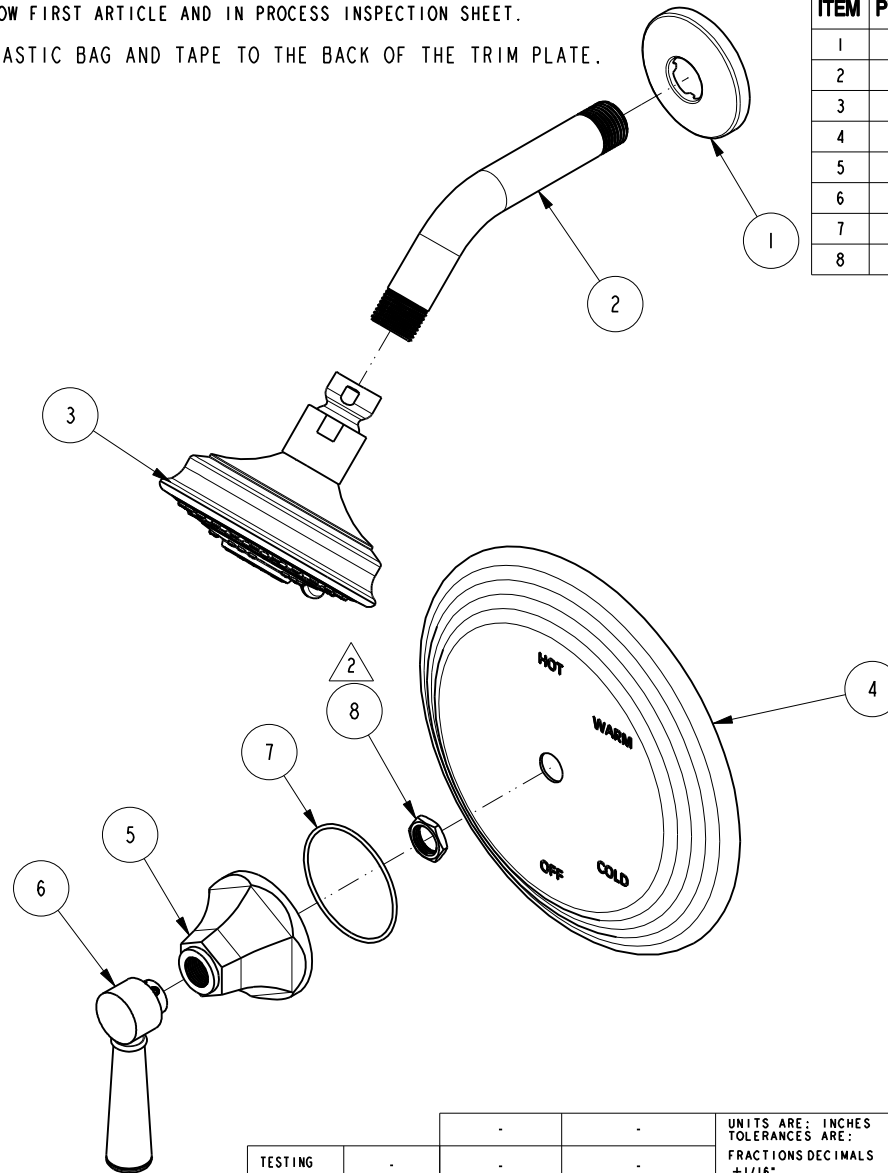

ZONE	REV	DESCRIPTION	DATE	APPROVED
-	H	EN-4441	04/18/22	N.S.
-	G	EN-4300e	04/28/21	R.S.
-	F	EN-3722	02/08/19	C.G.
-	E	EN-2802	09/09/14	-
-	D	EN-2266	04/08/13	-
-	C	EN-1745	08/22/11	-
-	B	EN-1183	03/23/09	-

COPYRIGHT 2005 BRASSTECH, INC. THESE DRAWINGS AND THE DESIGNS DEPICTED HEREIN ARE THE PROPRIETARY PROPERTY OF BRASSTECH. ANY USE OR REPRODUCTION IS SUBJECT TO THE EXPRESS APPROVAL OF BRASSTECH. UNAUTHORIZED USE IS STRICTLY PROHIBITED. ALL RIGHTS RESERVED.

TESTING	ASSEMBLY	PLATING	POLISHING	MACHINING	TOOLING FIXTURE #	APPLICATION
-	-	-	-	-	-	REMOVE ALL BURRS AND SHARP EDGES

UNITS ARE: INCHES [MM]	
TOLERANCES ARE:	
FRACTIONS	DECIMALS
±1/16"	.XX ±.06 [1,5]
.X ±.1 [2,5]	ANGLES ±°
(X.XXX) DENOTES CRITICAL DIMS.	
ALL THREADS ARE CRITICAL	
DRAWN	J.T.
CHECKED	N.S.
APPROVED	N.S.
DATE	04/18/22
DATE	04/18/22

**BRASSTECH** 2001 CARNEGIE AVE. SANTA ANA, CA 92705 (949) 417-5207  
INCORPORATED

**TRIM KIT - BP SHOWER SET**

DWG NO. **3-1204BP** REV **H**

SCALE **.300** REF. - SHEET **1** OF **2**

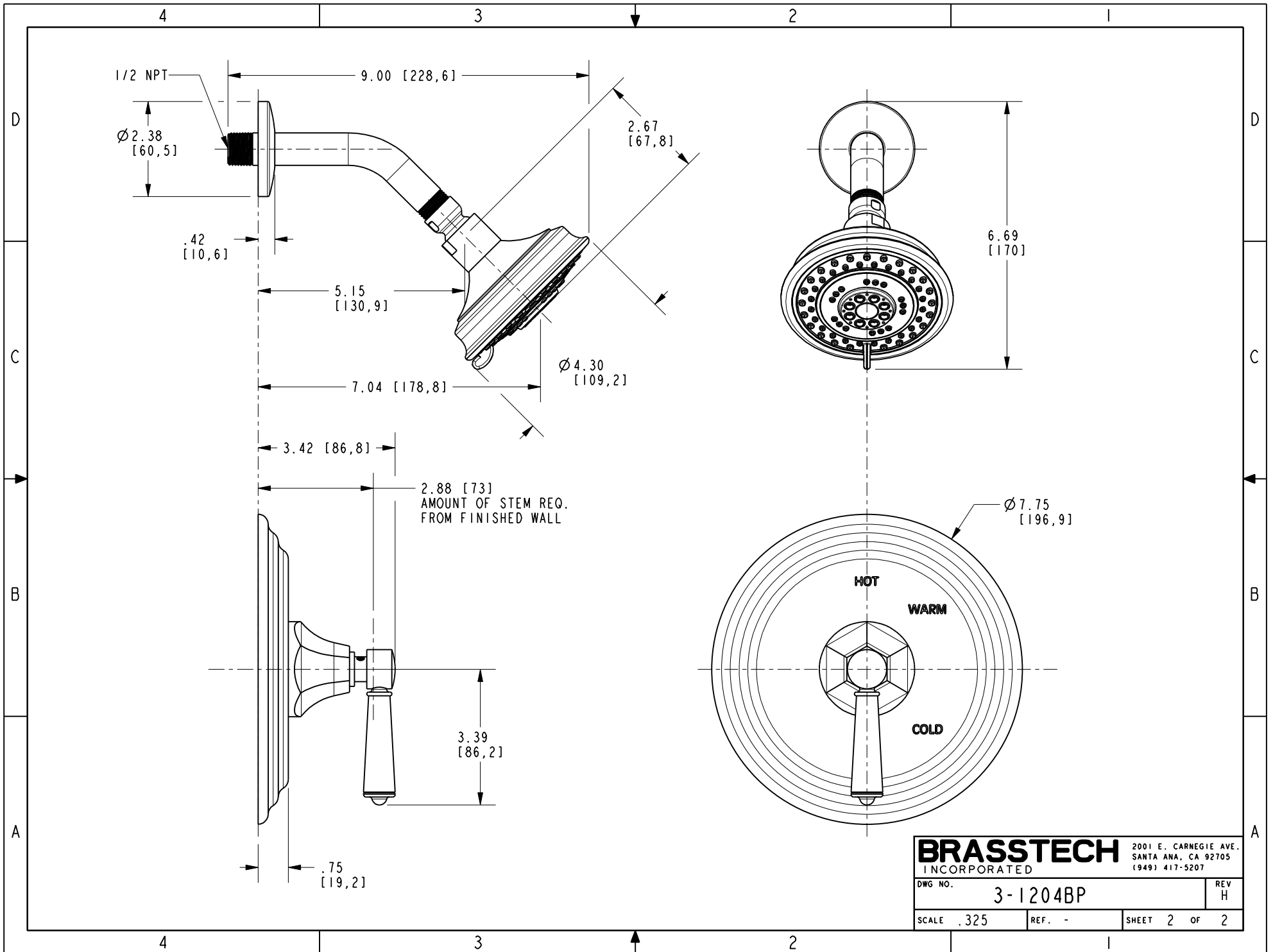

<b>BRASSTECH</b>		2001 E. CARNEGIE AVE. SANTA ANA, CA 92705 (949) 417-5207	
DWG NO.	3-1204BP		REV H
SCALE .325	REF. -	SHEET 2 OF 2	