

NOTES:

(N1) 1. FIT / FORM / FUNCTION SHALL FOLLOW PS-E.008.

BILL OF MATERIAL (CURRENT LEVEL)

ITEM	PT/ASSY	DESCRIPTION	TYPE	QTY.
1	5081SO	16" GRAB BAR BRAZE ASM	ASSEMBLY	1
2	20-287	GRAB BAR MOUNTING HARDWARE PACK	ASSEMBLY	2
3	40677	DECORATIVE RING	PART	2
4	92308	SCRW, M5 X 5 SKT HD CUP PT SS	PART	2

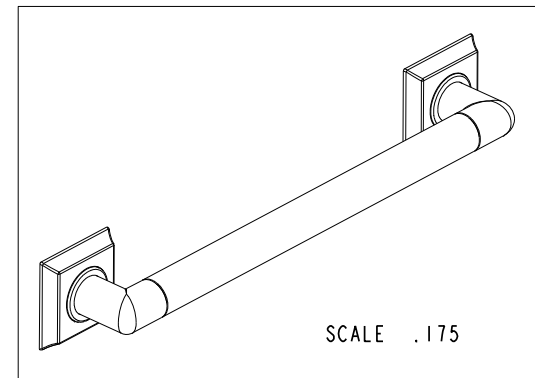
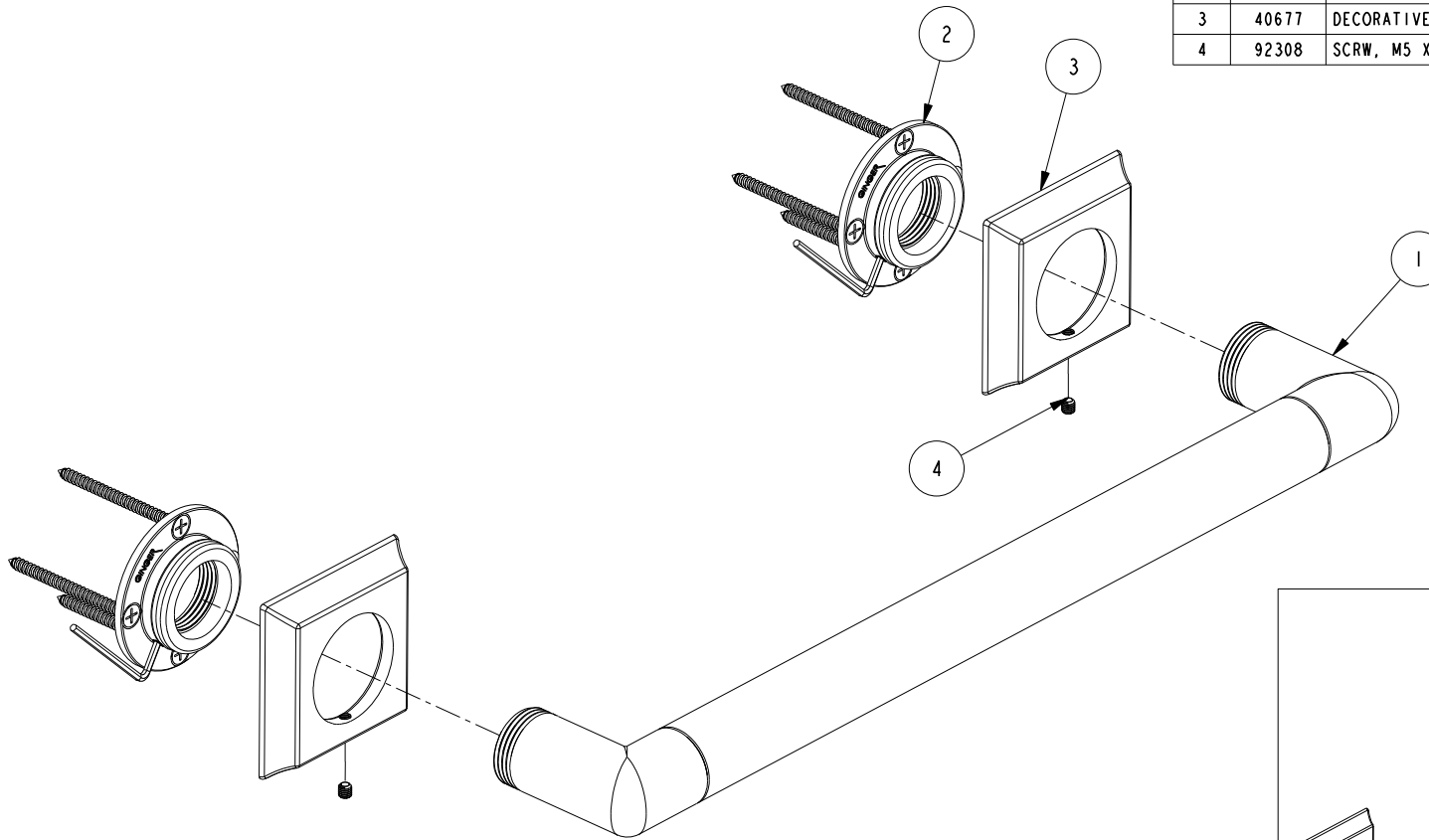

COPYRIGHT 2005 BRASSTECH, INC.
 THESE DRAWINGS AND THE DESIGNS
 DEPICTED HEREIN ARE THE PROPRIETARY
 PROPERTY OF BRASSTECH. ANY USE
 OR REPRODUCTION IS SUBJECT TO
 THE EXPRESS APPROVAL OF BRASSTECH.
 UNAUTHORIZED USE IS STRICTLY
 PROHIBITED. ALL RIGHTS RESERVED.

TESTING	-	-	-	UNITS ARE: INCHES [MM]
ASSEMBLY	-	-	-	TOLERANCES ARE:
PLATING	-	-	-	FRACTIONS DECIMALS ANGLES
POLISHING	-	-	-	±1/16" .X ±.1 [2.5] ±1°
MACHINING	-	NEXT ASSY	USED ON	.XX ±.06 [1.5]
TOOLING FIXTURE #				(X.XXX) DENOTES CRITICAL DIMS. ALL THREADS ARE CRITICAL
				DRAWN R.S. 04/17/17
				CHECKED J.M. 04/17/17
				APPROVED J.M. 04/17/17
				REMOVE ALL BURRS AND SHARP EDGES

BRASSTECH 2001 CARNEGIE AVE.
 INCORPORATED SANTA ANA, CA 92705
 (949) 417-5207

GRAB BAR 16"

DWG NO.	2570-3916	REV	-
SCALE	.350	REF.	-
SHEET	1	OF	2

EN-3279b	04/17/17	J.M.		
ZONE	REV	DESCRIPTION	DATE	APPROVED

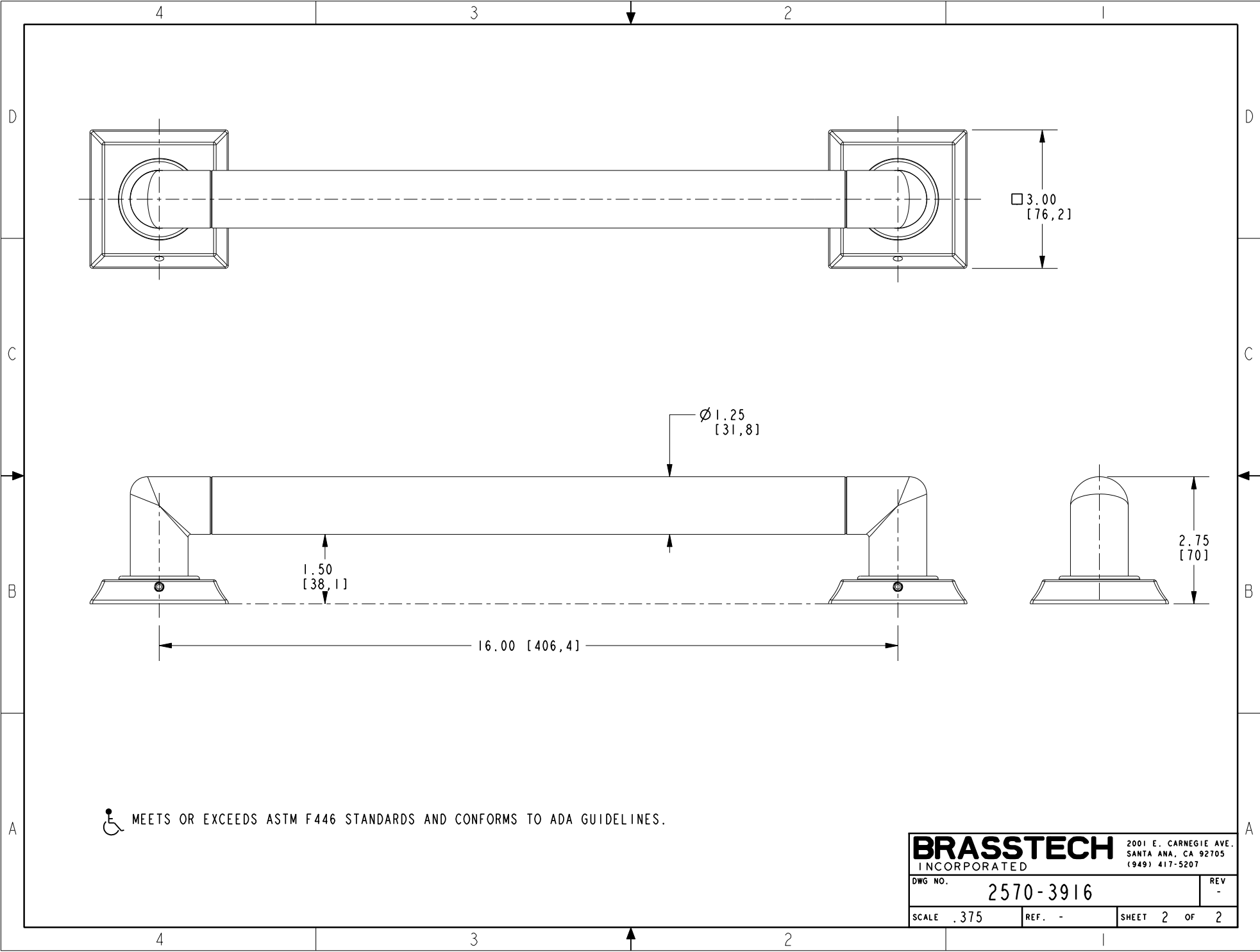

 MEETS OR EXCEEDS ASTM F446 STANDARDS AND CONFORMS TO ADA GUIDELINES.

BRASSTECH		2001 E. CARNEGIE AVE.	
INCORPORATED		SANTA ANA, CA 92705	
		(949) 417-5207	
DWG NO.	2570-3916	REV	-
SCALE	.375	REF.	-
		SHEET	2 OF 2