

NOTES:

1. FIT / FORM / FUNCTION SHALL FOLLOW PS-E.008.

BILL OF MATERIAL (CURRENT LEVEL)

ITEM	PT/ASSY	DESCRIPTION	TYPE	QTY.
1	40784	TOILET TISSUE HOLDER BACKPLATE	PART	1
2	7-760	BRAZED TISSUE HOLDER POST - LEFT	ASSEMBLY	1
3	7-761	BRAZED TISSUE HOLDER POST - RIGHT	ASSEMBLY	1
4	92031	SCRW, M6 X 1 X 6 SKT HD CUP PT W/ SELF LOC SS	PART	2
5	28XXG	MOUNTING BRACKET	PART	2
6	1-206	HARDWARE PACK	ASSEMBLY	2
7	2808T	TOILET TISSUE ROLLER ASSEMBLY	ASSEMBLY	1
8	10615	HEX KEY, 3MM ALLOY STEEL	PART	1

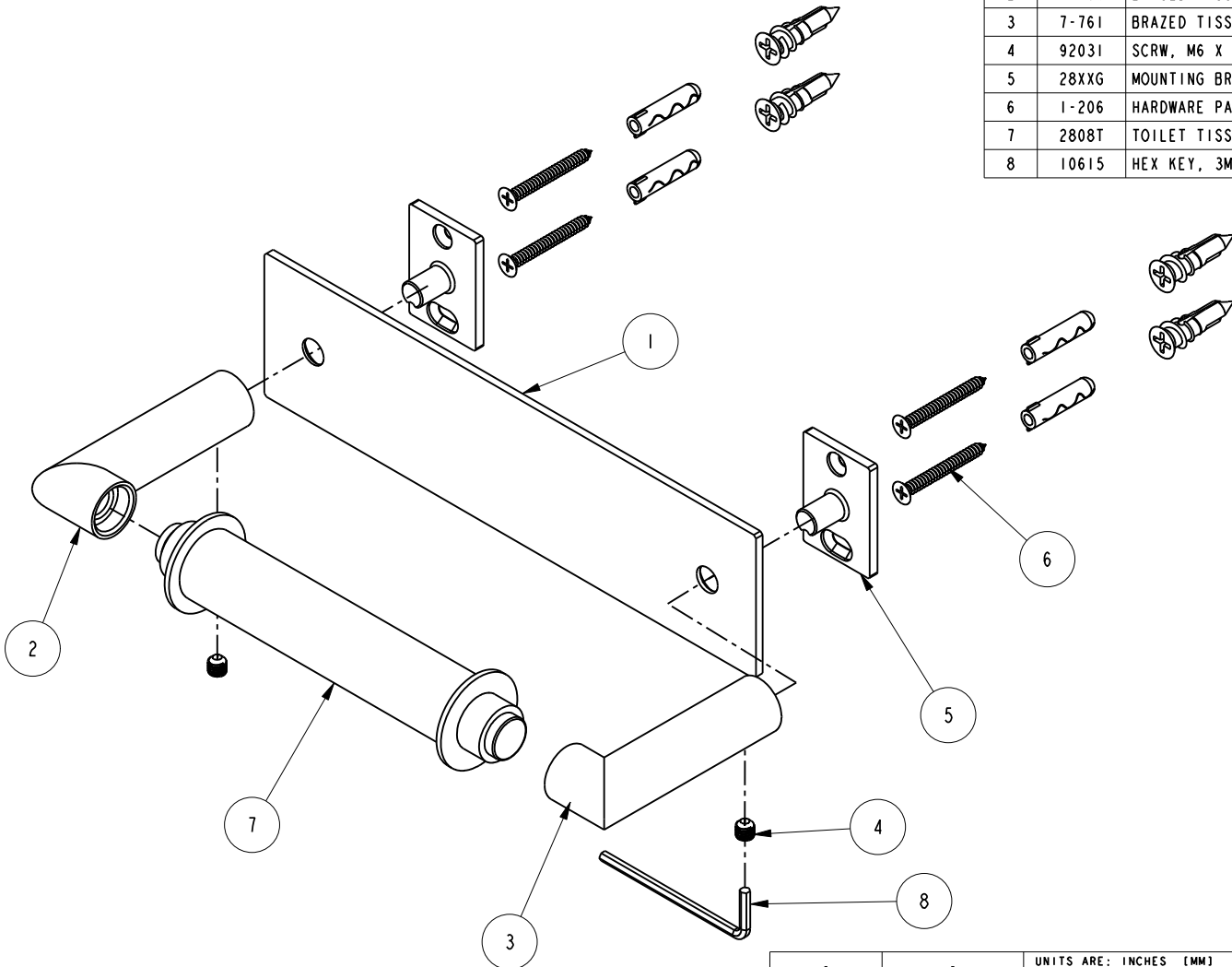

ZONE	REV	DESCRIPTION	DATE	APPROVED
-	B	EN-4069	01/23/20	J.M.
-	A	EN-4022	11/12/19	J.M.
-	-	EN-3912	08/02/19	J.M.

COPYRIGHT 2005 BRASSTECH, INC. THESE DRAWINGS AND THE DESIGNS DEPICTED HEREIN ARE THE PROPRIETARY PROPERTY OF BRASSTECH. ANY USE OR REPRODUCTION IS SUBJECT TO THE EXPRESS APPROVAL OF BRASSTECH. UNAUTHORIZED USE IS STRICTLY PROHIBITED. ALL RIGHTS RESERVED.

TESTING	ASSEMBLY	PLATING	POLISHING	MACHINING	TOOLING FIXTURE #
-	-	-	-	-	-
-	-	-	-	-	-
-	-	-	NEXT ASSY	USED ON	-
-	-	-	-	APPLICATION	-
-	-	-	-	REMOVE ALL BURRS AND SHARP EDGES	-

UNITS ARE: INCHES [MM]	TOLERANCES ARE:
FRACTIONS DECIMALS	ANGLES
±1/16"	.X ±.1 [2.5] ±1°
	.XX ±.06 [1.5]
(X.XXX) DENOTES CRITICAL DIMS. ALL THREADS ARE CRITICAL	
DRAWN	G.B. 08/02/19
CHECKED	J.M. 08/02/19
APPROVED	J.M. 08/02/19

**BRASSTECH** INCORPORATED  
 2001 CARNEGIE AVE. SANTA ANA, CA 92705 (949) 417-5207

**DOUBLE POST TP HOLDER**

DWG NO. **2540-1500** REV B

SCALE .450 REF. - SHEET 1 OF 2

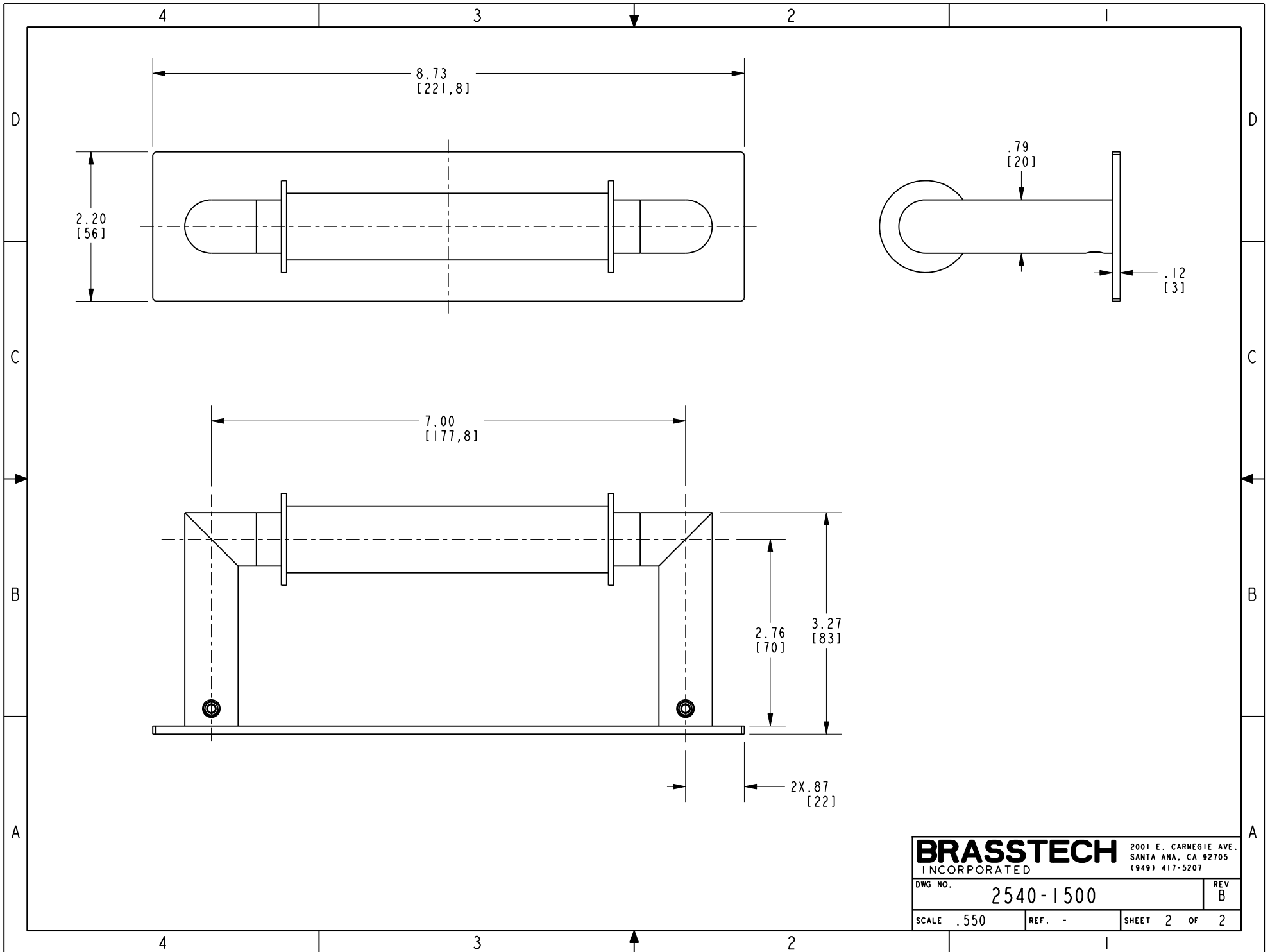

<b>BRASSTECH</b>		2001 E. CARNEGIE AVE.	
INCORPORATED		SANTA ANA, CA 92705	
DWG NO. 2540-1500		REV B	
SCALE .550	REF. -	SHEET 2 OF 2	