

4

3

2

NOTES:

(N1) 1. FIT / FORM / FUNCTION SHALL FOLLOW PS-E.008.

BILL OF MATERIAL (CURRENT LEVEL)

ITEM	PT/ASSY	DESCRIPTION	TYPE	QTY.
1	20-287	GRAB BAR MOUNTING HARDWARE PACK	ASSEMBLY	3
2	5086	42" GRAB BAR, ADAPTER AND POST ASSY	ASSEMBLY	1
3	40681	GRAB BAR TRIM RING	PART	3

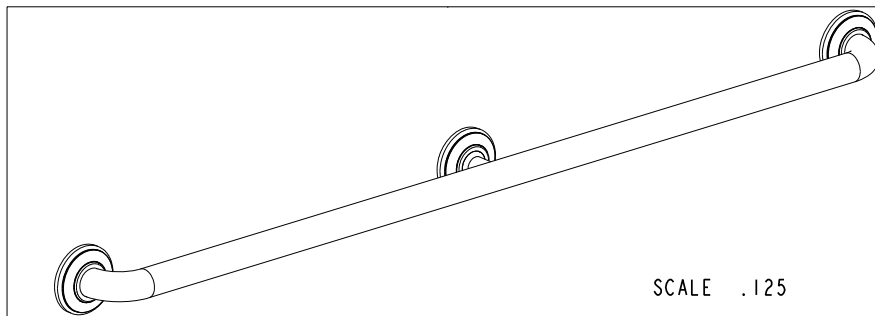
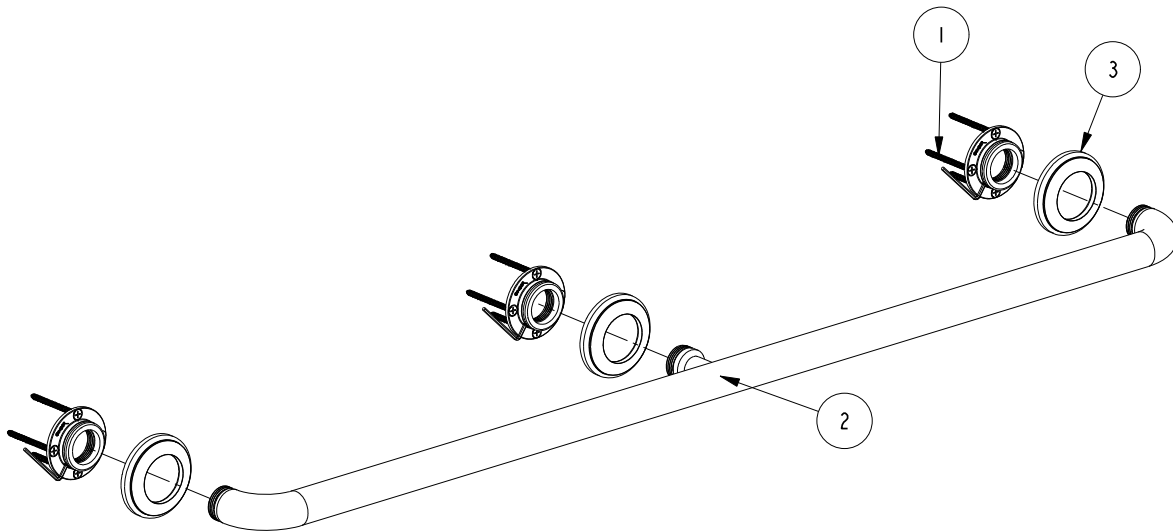

COPYRIGHT 2005 BRASSTECH, INC.
 THESE DRAWINGS AND THE DESIGNS
 DEPICTED HEREIN ARE THE PROPRIETARY
 PROPERTY OF BRASSTECH. ANY USE
 OR REPRODUCTION IS SUBJECT TO
 THE EXPRESS APPROVAL OF BRASSTECH.
 UNAUTHORIZED USE IS STRICTLY
 PROHIBITED. ALL RIGHTS RESERVED.

-	-	EN-3279b	07/13/17	J.M.
ZONE	REV	DESCRIPTION	DATE	APPROVED

TESTING	-	-	-
ASSEMBLY	-	-	-
PLATING	-	-	-
POLISHING	-	NEXT ASSY	USED ON
MACHINING	-	APPLICATION	
TOOLING	FIXTURE #	REMOVE ALL BURRS AND SHARP EDGES	

UNITS ARE: INCHES [MM]	
TOLERANCES ARE:	
FRACTIONS	DECIMALS
±1/16"	.X ±.1 [2.5]
	.XX ±.06 [1.5]
(X.XXX) DENOTES CRITICAL DIMS.	
ALL THREADS ARE CRITICAL	
DRAWN	R.S. 07/13/17
CHECKED	J.M. 07/13/17
APPROVED	J.M. 07/13/17

BRASSTECH 2001 CARNEGIE AVE.
 INCORPORATED SANTA ANA, CA 92705
 (949) 417-5207

42" CURVED GRAB BAR ASSEMBLY

DWG NO. **2440-3942** REV -

SCALE .150 REF. - SHEET 1 OF 2

4

3

2

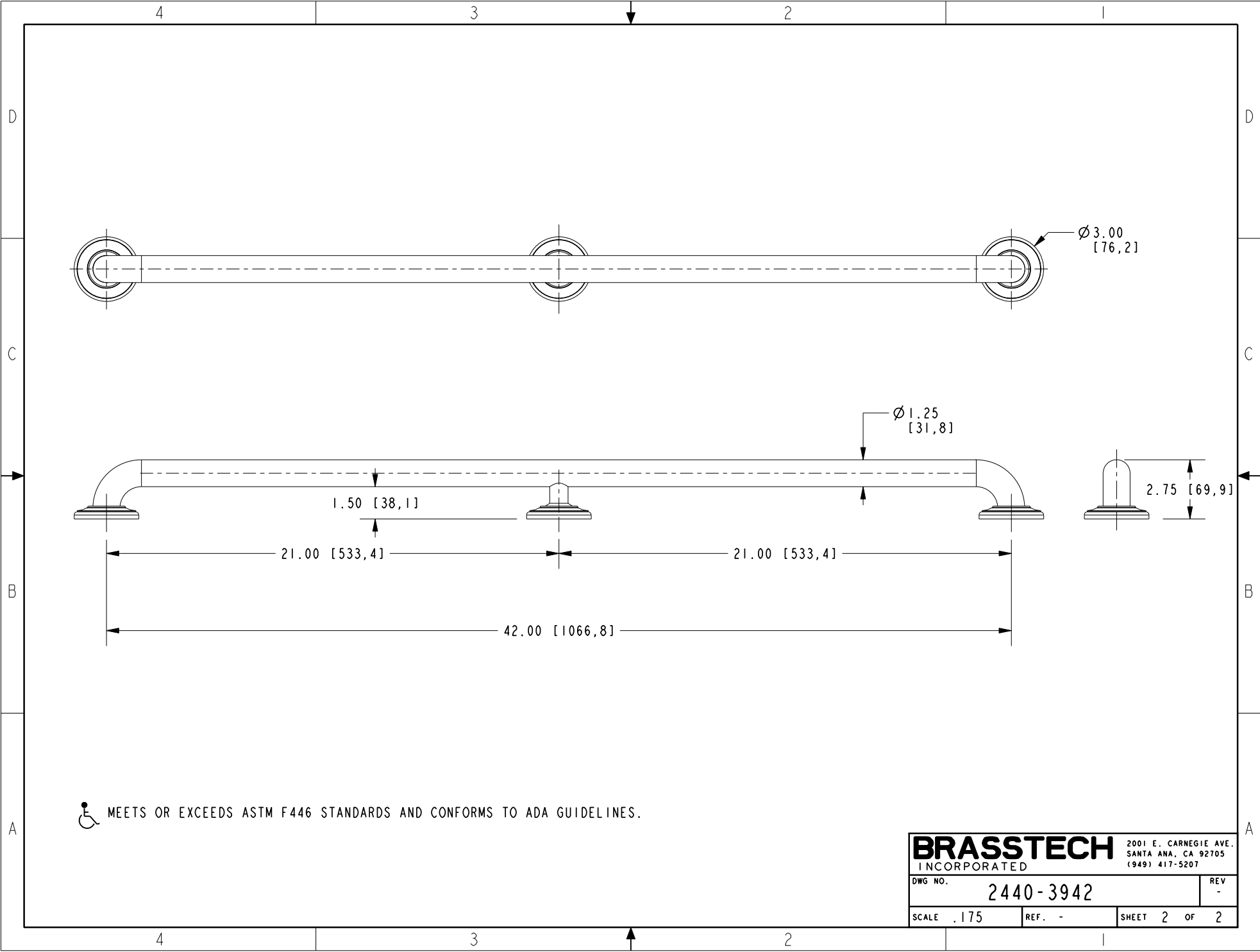

Ø 3.00
[76,2]

Ø 1.25
[31,8]

1.50 [38,1]

2.75 [69,9]

21.00 [533,4]

21.00 [533,4]

42.00 [1066,8]

 MEETS OR EXCEEDS ASTM F446 STANDARDS AND CONFORMS TO ADA GUIDELINES.

BRASSTECH		2001 E. CARNEGIE AVE. SANTA ANA, CA 92705 (949) 417-5207	
INCORPORATED			
DWG NO.	2440-3942	REV	-
SCALE	.175	REF.	-
		SHEET	2 OF 2