

NOTES:

(N1) 1. FIT / FORM / FUNCTION SHALL FOLLOW PS-E.008.

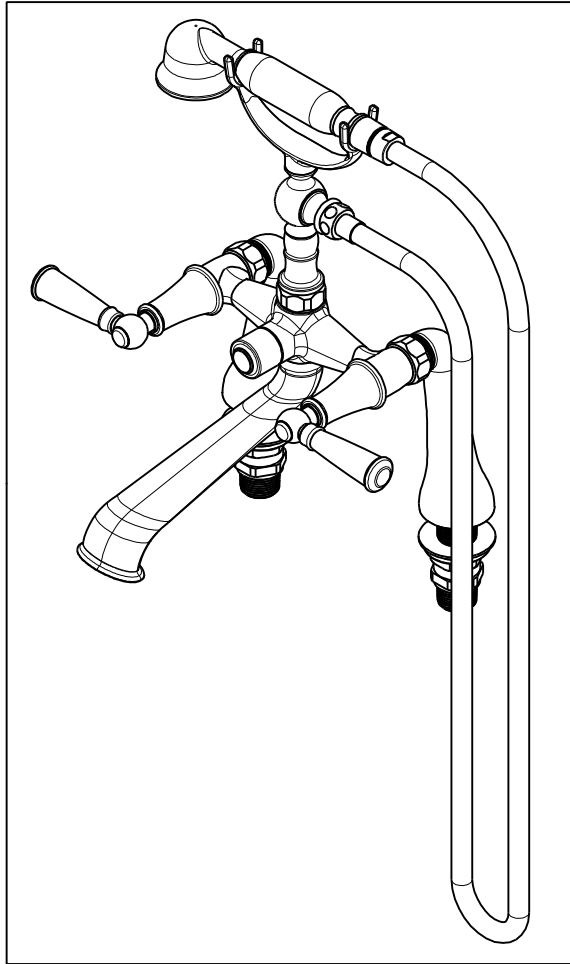

BILL OF MATERIAL (CURRENT LEVEL)

ITEM	PT/ASSY	DESCRIPTION	TYPE	QTY.
1	12894	BODY - FOR 933.934	PART	1
2	2-220	RISER ASM	ASSEMBLY	1
3	284_	59 IN. SPIRAL SHOWER HOSE	ASSEMBLY	1
4	281	HANDSHOWER ASM	ASSEMBLY	1
5	12585	SPOUT	PART	1
6	91028	O-RING, #2- 018, EPDM, 65-75 DURO, NSF 61	PART	1
7	10442	SEAT FOR CARTRIDGE	PART	2
8	91020	O-RING, #2-016, EPDM, 65-75 DURO, NSF 61	PART	2
9	10332	HEX NUT	PART	2
10	91039	WSHR, .625 ID X 1.00 OD X .125 THK, RUBBER	PART	2
11	10336	LEG - LEFT	PART	1
12	10335	LEG - RIGHT	PART	1
13	1-049	MOUNTING HARDWARE	ASSEMBLY	1
14	1-325	W/S CARTRIDGE FRICTION - COLD	PART	1
15	1-326	W/S CARTRIDGE FRICTION - HOT	PART	1
16	12066	HANDLE BONNET - TUB FILLER	PART	2
17	12062	ADAPTER - 20-T X 16-T	PART	2
18	2-948	LEVER HANDLE ASSY	ASSEMBLY	2
19	92538	SCRW, M4 X 25 SKT BUTTON FLANGE HD CAP BLACK-OXIDE	PART	2
20	10159	HEX KEY, 3/32 ALLOY STEEL	PART	1
21	20-260	DIVERTER ASM	ASSEMBLY	1
22	20-259	DIVERTER ASM	ASSEMBLY	1
23	13313	DIVERTER BUTTON	PART	1

EN-4123
C.GAYOSSO 03/04/2020

ZONE	REV	DESCRIPTION	DATE	APPROVED
-	C	EN-3565A	01/30/20	C.G.
-	B	EN-3150a	05/18/17	J.M.
-	A	EN-2818	11/20/14	A.N.
-	-	EN-2606	04/14/14	-

COPYRIGHT 2005 BRASSTECH, INC. THESE DRAWINGS AND THE DESIGNS DEPICTED HEREIN ARE THE PROPRIETARY PROPERTY OF BRASSTECH. ANY USE OR REPRODUCTION IS SUBJECT TO THE EXPRESS APPROVAL OF BRASSTECH. UNAUTHORIZED USE IS STRICTLY PROHIBITED. ALL RIGHTS RESERVED.

TESTING	-	-	-
ASSEMBLY	-	-	-
PLATING	-	-	-
POLISHING	-	NEXT ASSY	USED ON
MACHINING	-	APPLICATION	
TOOLING FIXTURE #		REMOVE ALL BURRS AND SHARP EDGES	

UNITS ARE: INCHES [MM]		
TOLERANCES ARE:		
FRACTIONS DECIMALS	ANGLES	
±1/16"	.X ±.1 [2.5]	±1°
	.XX ±.06 [1.5]	
(X.XXX) DENOTES CRITICAL DIMS. ALL THREADS ARE CRITICAL		
DRAWN	JINSON	01/30/20
CHECKED	C.G.	01/30/20
APPROVED	C.G.	01/30/20

BRASSTECH 2001 CARNEGIE AVE. SANTA ANA, CA 92705 (949) 417-5207
INCORPORATED

EXPOSED TUB/ HANDSHOWER, DECK MOUNT - LEVER HANDLE

DWG NO.	2400-4273	REV	D
SCALE	.200	REF.	-
SHEET	1	OF	3

- △ 2 APPLY LOCTITE 680.
- △ 3 TORQUE TO 15-20 FT-LB.
- △ 4 APPLY LOCTITE 242 IF SCREW DOES NOT HAVE NYLON PATCH.
- △ 5 TORQUE TO 11-14 FT-LB.

6. VISIBLE GAP BETWEEN THE SPOUT AND BODY IS ACCEPTABLE UP TO .070".

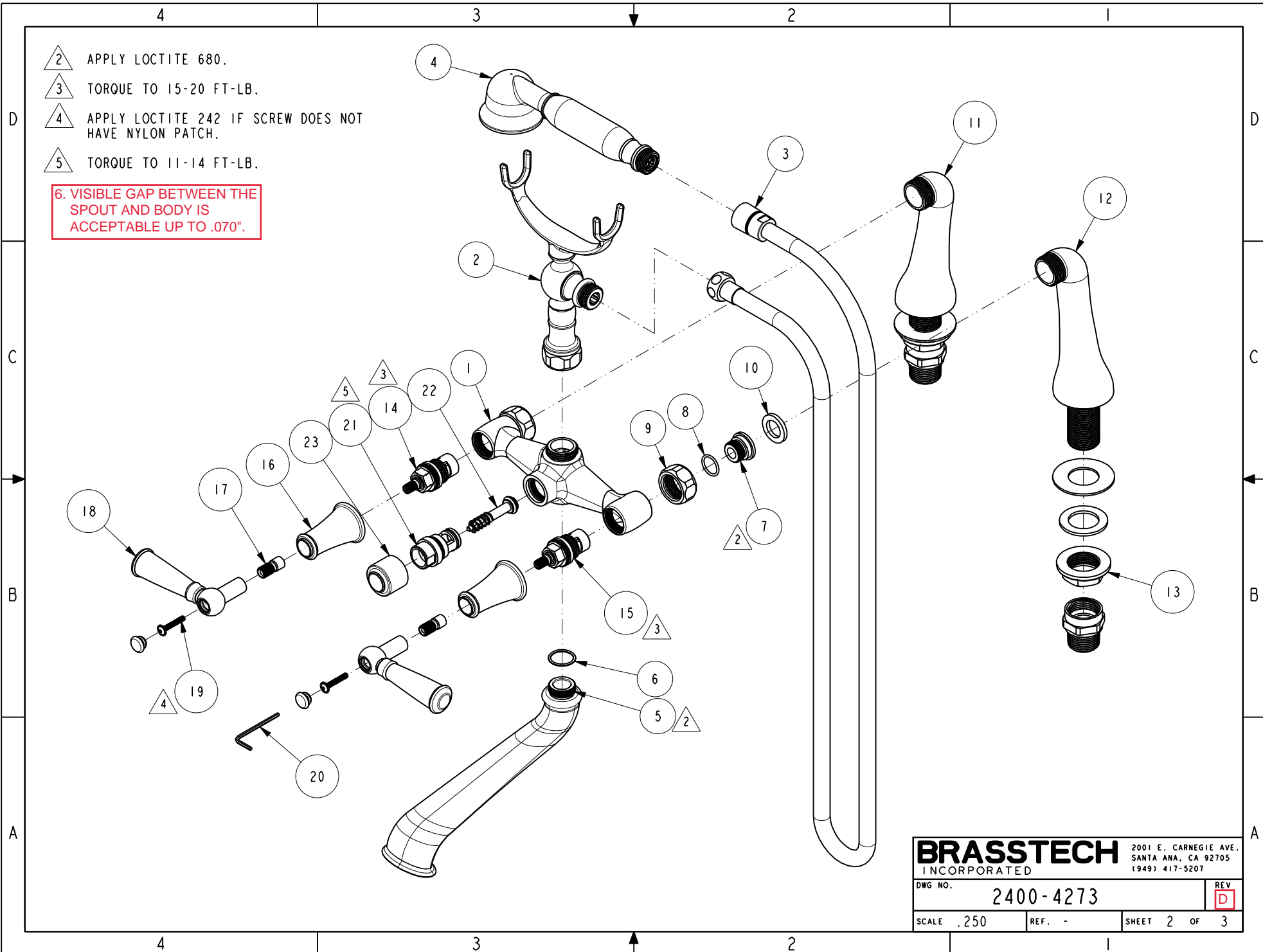

BRASSTECH		2001 E. CARNEGIE AVE. SANTA ANA, CA 92705 (949) 417-5207
DWG NO.	2400-4273	REV D
SCALE	REF.	SHEET 2 OF 3
.250	-	3

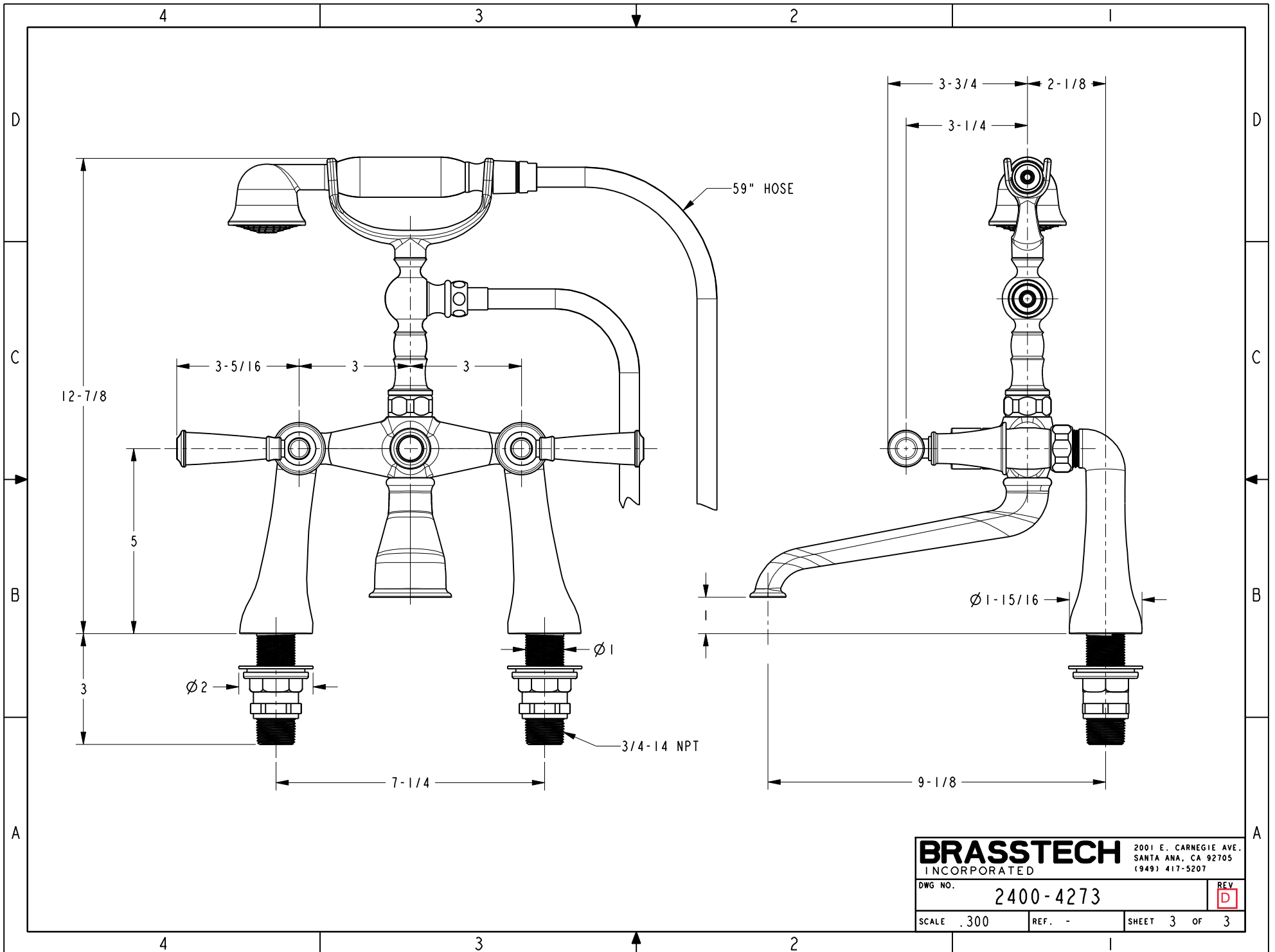

BRASSTECH		2001 E. CARNEGIE AVE. SANTA ANA, CA 92705 (949) 417-5207	
DWG NO.	2400-4273		REV D
SCALE	.300	REF.	-
SHEET 3		OF 3	