

NOTES:

- (N1) 1. FIT / FORM / FUNCTION SHALL FOLLOW PS-E.008.
- 2 APPLY ADHESIVE LOCTITE 680.
- 3 APPLY 3M SCOTH-WELD DP-100NS OR EQUIVALENT.
- 4 REMOVE METAL BURRS.
- 5 SCORE SURFACE.

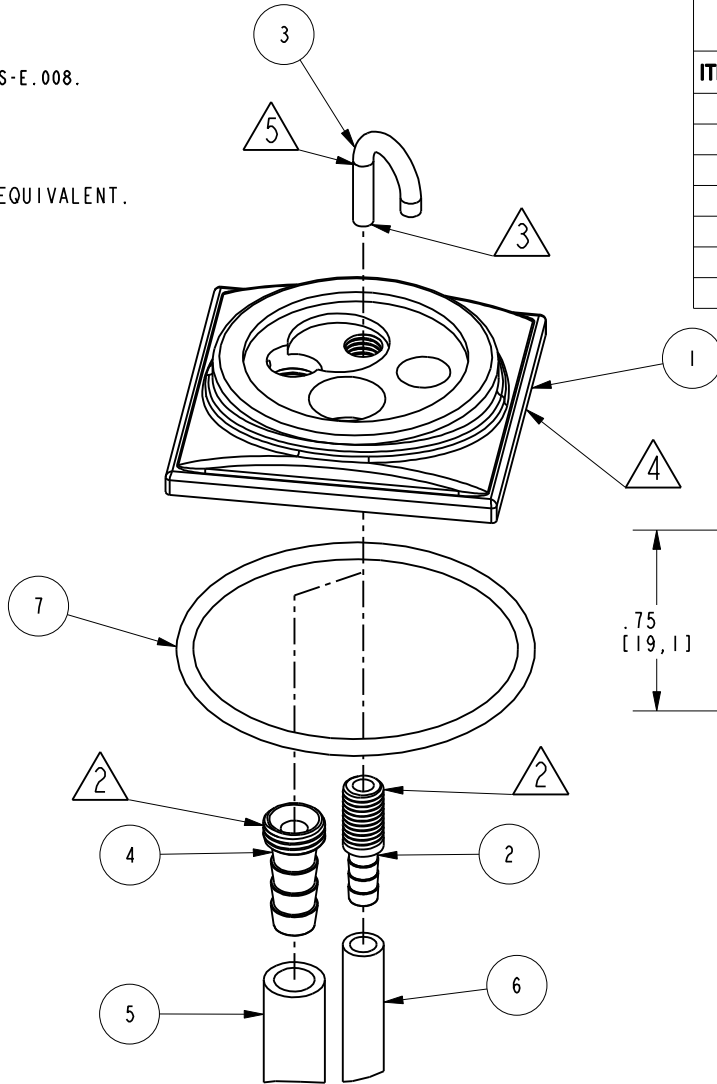
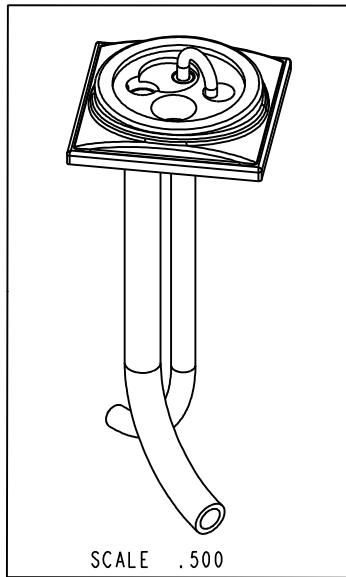

BILL OF MATERIAL (CURRENT LEVEL)

ITEM	PT/ASSY	DESCRIPTION	TYPE	QTY.
1	12739	ESCUTCHEON	PART	1
2	50772	1/4" BARBED TUBE FITTING	PART	1
3	50774	AIR GAP TUBE	PART	1
4	50789	3/8" BARBED TUBE FITTING	PART	1
5	91380	TUBE, BLACK 3/8 OD X 4 FT	PART	1
6	91381	TUBE, BLACK 1/4 OD X 4 FT	PART	1
7	91231	O-RING, #2-136, EPDM, 65-75 DURO	PART	1

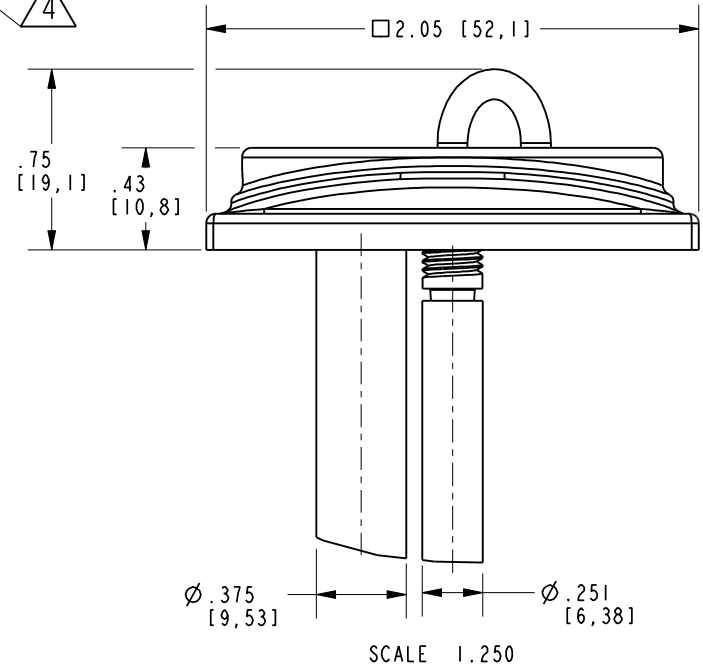

TESTING	-	-	-
ASSEMBLY	-	-	-
PLATING	-	3170-5623	3170-5623
POLISHING	-	NEXT ASSY	USED ON
MACHINING	-	APPLICATION	
TOOLING FIXTURE #	REMOVE ALL BURRS AND SHARP EDGES		

UNITS ARE: INCHES [MM]
 TOLERANCES ARE:
 FRACTIONS DECIMALS ANGLES
 $\pm 1/16"$ $.X \pm .1$ [2,5] $\pm 1"$
 $.XX \pm .06$ [1,3]

(X.XXX) DENOTES CRITICAL DIMS.
 ALL THREADS ARE CRITICAL

DRAWN AMARISH 04/25/17
 CHECKED RAVINDRA 04/25/17
 APPROVED J.M 04/25/17

BRASSTECH 2001 CARNEGIE AVE.
 INCORPORATED SANTA ANA, CA 92705
 (949) 417-5207

AIR GAP ASSEMBLY

DWG NO. 20-280 REV -
 SCALE .850 REF. - SHEET | OF |

COPYRIGHT 2005 BRASSTECH, INC.
 THESE DRAWINGS AND THE DESIGNS
 DEPICTED HEREIN ARE THE PROPRIETARY
 PROPERTY OF BRASSTECH. ANY USE
 OR REPRODUCTION IS SUBJECT TO
 THE EXPRESS APPROVAL OF BRASSTECH.
 UNAUTHORIZED USE IS STRICTLY
 PROHIBITED. ALL RIGHTS RESERVED.

EN-3076	04/25/17	J.M
ZONE	REV	DESCRIPTION
4		