

WIDE SPREAD KITCHEN SET
INSTALLATION INSTRUCTIONS
MODEL NO. 9911 & 9911L

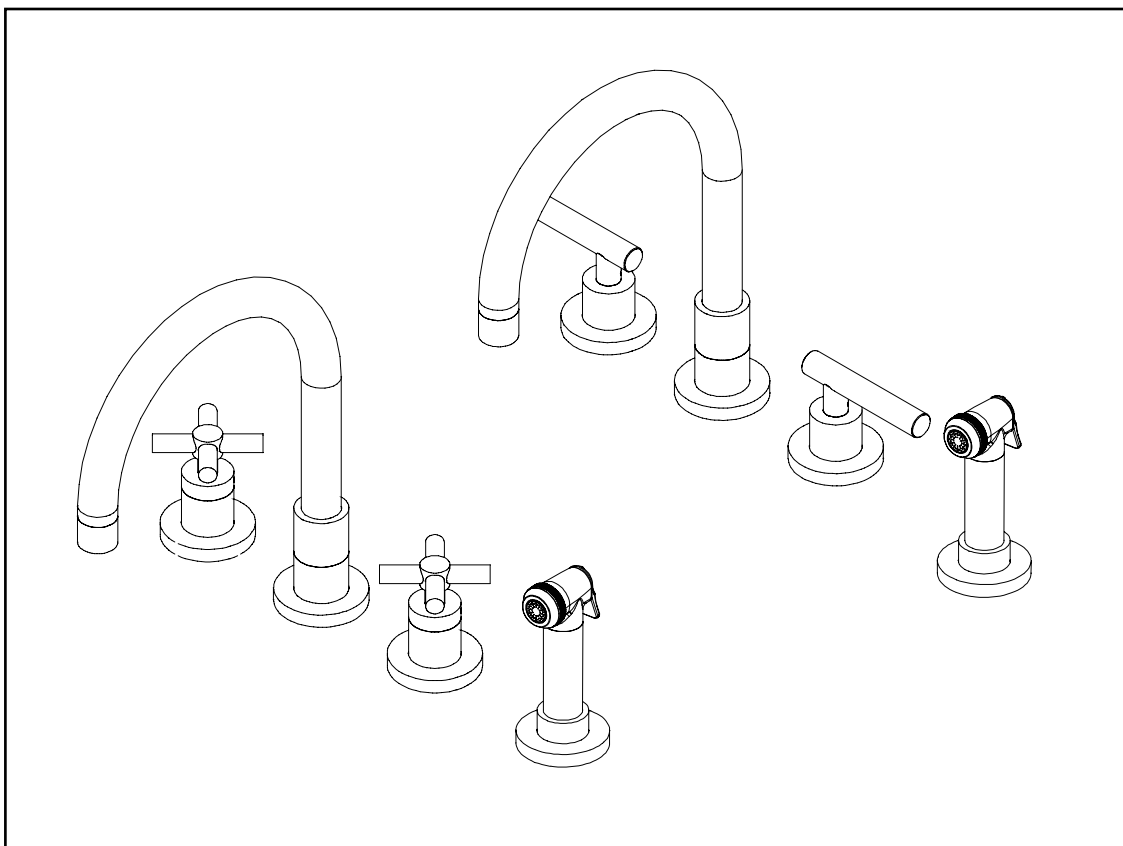

**Congratulations on the purchase
of your Newport Brass product,
an excellent choice, that will give you
years of quality service and enhance
the look and style of your home.**

Recommended Installation by a Professional Plumbing Contractor

Note: The use of petroleum base plumbers putty on our products will nullify the warranty. We recommend the use of clear silicone sealing materials. Recommended deck hole Ø1.25.

1. Thread flange NUT (5) onto the diverter SHANK (4). Install from underside through center hole of mounting surface. Place spout base RING (2) with WASHER (3) over SHANK (4). Thread SPOUT (1) onto end of SHANK (4). Secure into place with flange NUT (5). See Figure 1.
2. Place NUT (6) & WASHER (7) on valve BODY (8). Insert BODY (8), (blue cold and red hot), through hole in the mounting surface. Adjust and secure with additional WASHER (7) and NUT (6) so that the top of valve is 2" above mounting surface. Before tightening down flange NUT (6), check HANDLE (21, 21a) alignment by placing onto Valve (8). Any adjustments for rotational alignment must be made to the valve BODY (8), not to the cartridge. See Figure 1.
3. Insert vegetable spray HOSE (9) through BONNET (11) with O-RING (10), ESCUTCHEON (12) and mounting surface. From underside of mounting surface, insert HOSE (9) through SHANK (13), threading into BONNET (11). Insert Hose (9) through flange NUT (14), threading onto SHANK (13) to secure in place. Attach other end of vegetable spray HOSE (9) to base of diverter TEE (4). See Figure 2.
4. Connect large end of flexible HOSE (15) to side outlet of each valve BODY (8). Attach other end of HOSE (15) to either side of the TEE (4). (Hand-tighten and secure each connection with a wrench ¼ turn.) See Figure 3.
5. Connect hot/cold water supply to appropriate 1/2" NPSM valve BODY (8), utilizing one of the three following types of risers. Supply risers not included. See Figure 3.
 - a. 1/2" IPS flexible riser: discard rubber nosecone WASHER (16), friction WASHER (17) and coupling NUT (18).
 - b. 3/8" or 1/2" OD bullnose riser: utilize friction WASHER (17) and coupling NUT (18).
 - c. 1/2" copper riser: utilize rubber nosecone WASHER (16), friction WASHER (17) and coupling NUT (18).
6. Thread ESCUTCHEON (19) and BONNET (20) onto valve. Any adjustments for rotational alignment must be made to the valve body - not to the cartridge. (Note: Allow minimum spacing between HANDLE (21, 21a) and BONNET (20) to prevent damage to the surface finish.) Attach HANDLE (21, 21a) and secure into place with SETSCREW (22). See Figure 4.
7. Remove AERATOR (23) from SPOUT (1), turn on water supply, and flush both valves until water is clear. Check for leaks and make any final adjustments required. Re-attach AERATOR (23) to the SPOUT (1).

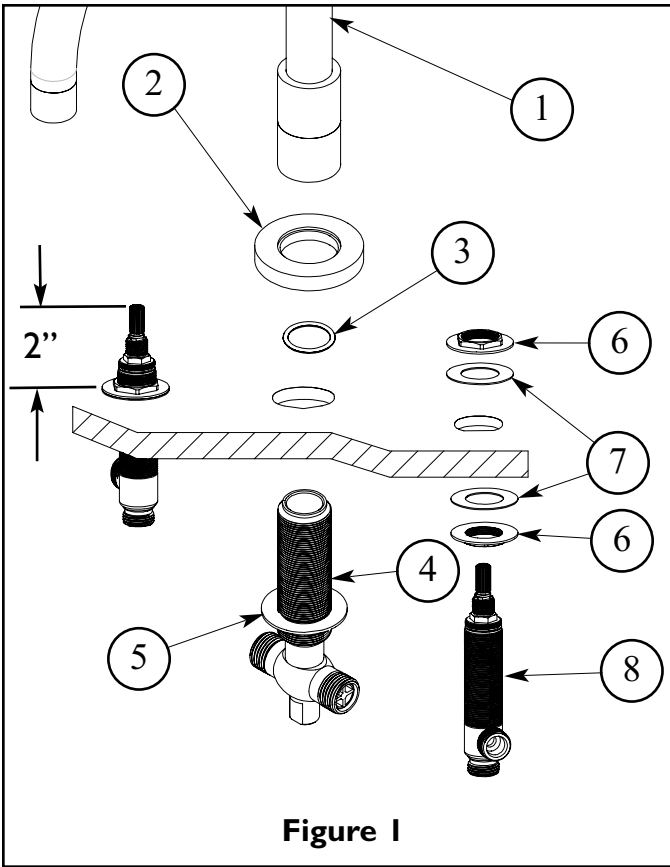

Figure 1

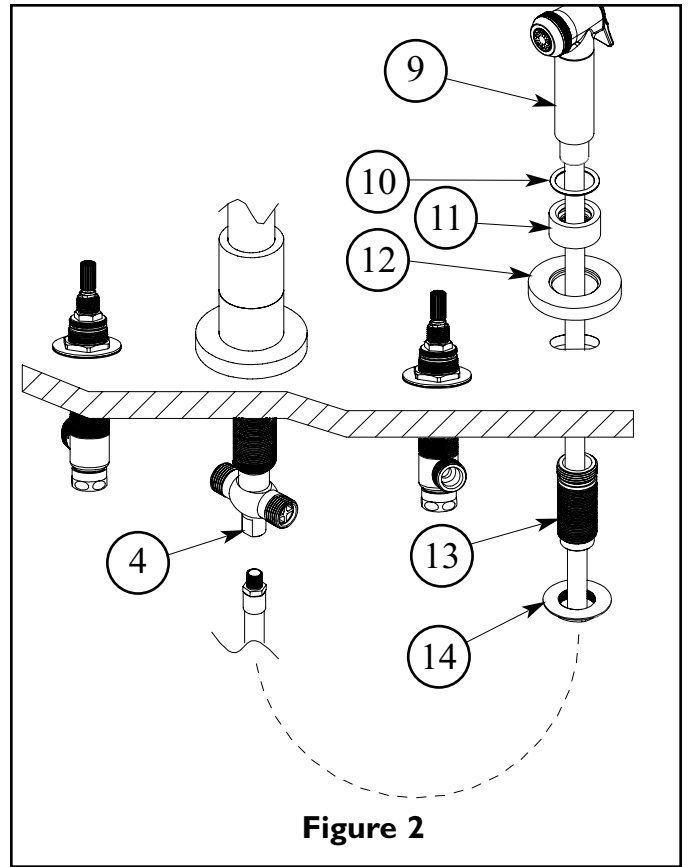

Figure 2

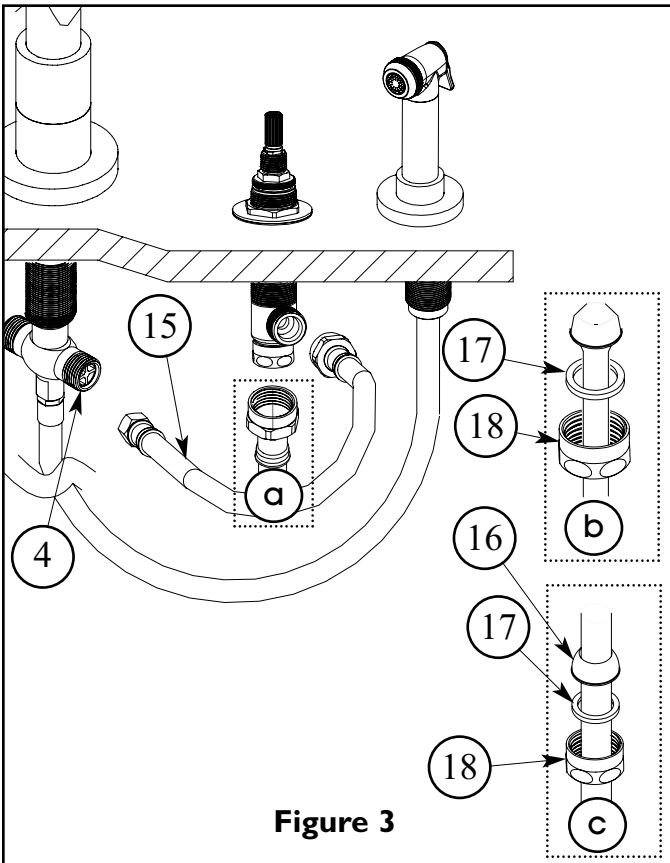

Figure 3

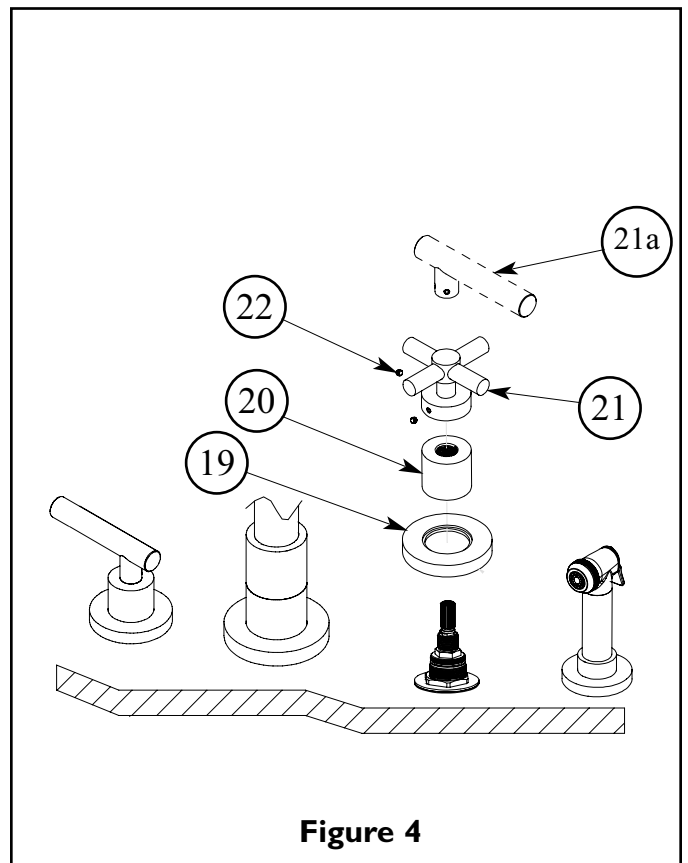

Figure 4

Newport Brass Product Care

Newport Brass faucets and bath fittings are made of solid brass and are of the finest quality. To maintain the finish on these items, please:

- Do not use any abrasive cleaners, detergents, brass or silver polish which will scratch the surface.
- Clean with a soft damp cloth.

Applying a coating of a non-abrasive liquid wax to the clean surface of the product will keep it looking beautiful. Brass ProTech, a product of Brasstech, Inc., can be used on all types of decorative painted and plated finishes.

Simply apply Brass ProTech with a soft cloth and let it dry. Then remove by rubbing gently with a soft dry cloth. Brass ProTech contains no harsh abrasives.

We highly recommend using Brass ProTech on items finished in Satin Nickel (15S), Polished Nickel (15), Polished Silver (25) and Satin Silver (25S). Do not allow soap scum or minerals in water to build up on the surface finish of your faucets or bath fittings (including toothpaste). These will gradually eat into any finish and diminish the beauty of your Newport Brass products.

Flush pipes prior to installation: Solder and other debris may damage ceramic discs. Cartridges are factory set at 14–16 lbs. torque.

Limited Warranty

Brasstech, Inc. (“Brasstech”) warrants to the original consumer residential purchaser (“Original Purchaser”) that if a Brasstech product (“Product”) is confirmed upon inspection to be non-conforming in materials or workmanship during the warranty periods described below, Brasstech will, at its option, either repair or replace the Product with a similar current model of the Product. If repair or replacement is not commercially practical or cannot be made in a timely manner, then Brasstech will provide a refund for the Product.

Warranty Periods and Coverage

Product Finishes

- PVD, Powder Coat Epoxy, including Oil Rubbed Bronze (10B) and Polished Chrome (26) finishes on Products other than Drains are warranted as long as the Original Purchaser owns their home.
- All other finishes are warranted for ten (10) years from date of purchase by the Original Purchaser, with the exception of uncoated or “living” finishes, which have no warranty*.

Drain Finishes

- Powder Coat Epoxy, Polished Chrome (26), Satin Chrome (26D), Oil Rubbed Bronze (10B), Forever Brass PVD (01), Satin Brass PVD (04) and Stainless Steel PVD (20) finishes on kitchen, bath or lavatory drains of all types (“Drains”) are warranted for one (1) year from date of purchase by the Original Purchaser.
- All other Drain finishes have no warranty.

Functionality

- All Product parts except valves are warranted for 10 years from date of purchase by the Original Purchaser.
- Ceramic disc valves for the lavatory faucet, tub/shower and roman tub are warranted for as long as the Original Purchaser owns the home.
- All other valves (balance pressure, thermostatic, etc.) are warranted for one (1) year from date of purchase by the Original Purchaser

Exclusions from Coverage

This Warranty does not cover labor charges or associated costs for, or damages occurring during the removal, transportation, return or installation of Products or replacement Products.

This Warranty does not cover damage or non-conformance due to misuse, abuse, hard water, improper storage, improper handling, improper maintenance**, improper installation*** or uses other than normal household usage****.

This Warranty is not transferable.

Limitations on Remedies

In no event will Brasstech be liable for incidental or consequential damages (such as labor charges), whether based on breach of express or implied warranty, breach of contract, negligence, strict liability or any other legal theory. Some states do not allow the exclusion or limitation of incidental or consequential damages, so, the above limitation or exclusion may not apply to you.

Any implied warranties, including the implied warranties of merchantability and fitness for a particular purpose, are limited to the duration of this written warranty. Some states do not allow limitations on how long an implied warranty may last, so the above limitation may not apply to you.

Warranty Service

To obtain service under this Warranty, please contact your Product dealer. If you are unable to locate your dealer, please call 949-417-5207 or access the Brasstech, Inc. website at www.brasstech.com. Proof of purchase, such as the original purchase order, is required to issue credit to the distributor.

State Remedies

This Warranty gives you specific legal rights, and you may have other rights which vary from state to state.

* **Uncoated and Living Finishes** Uncoated finishes such as Polished Brass Uncoated (03N) and weathered finishes such as Weathered Brass (03W) and Weathered Copper (08W) are intended to naturally weather and do change color over time. Living and uncoated finishes are not warranted.

** **Maintenance** Proper maintenance is required to preserve all finishes. Do not use any abrasive cleaners, alcohol, ammonia, detergents, or brass or silver polish on the Products. For complete care requirements and recommendations, please visit our website at www.brasstech.com.

*** **Proper Installation** Products must be installed in accordance with the manufacturer’s installation instructions supplied with the Products.

For example, pipes must be flushed before faucet installations, because solder and other debris may damage ceramic discs. You may also call 949-417-5207 for copies of the installation instructions. Many of our installation instructions are also available on our website, www.brasstech.com.

**** **Commercial Purchasers** Brasstech extends the above limited warranty to purchasers of Products for industrial, commercial and business use upon the same terms and conditions and exclusions applicable to residential purchasers, except that the finish and functionality warranty periods are reduced to a period of one (1) year from the date of purchase. ***Additionally, with respect to commercial purchasers, all implied warranties, including the implied warranties of merchantability and fitness for a particular purpose are excluded and disclaimed.***

(949) 417-5207

NWP-9911

Santa Ana, CA 92705

12/08/05

www.brasstech.com