

WALL MOUNT TUB FAUCET KIT

Installation Instructions Models I-500T

We Recommend Installation by a Professional Plumbing Contractor

Note: Use Teflon tape or equivalent to seal all threaded port joints.

Warning: To prevent severe damage to valve body, any solder/braze process must be performed a min. of 4" from ports. Remove cartridge from valve body prior to applying any heat/flame.

1. Turn off water to valve.
2. Install elbow into 1/2" NPT outlet port. Position elbow in the direction required for your application .
3. Check the horizontal and vertical level of valve BODY (1) by placing bubble level on STEMS (4, 5). Make any necessary adjustments. Secure valve BODY (1) to cross BRACE (2) using suitable SCREW (3), not included.
4. Solder/Braze hot and cold water inlets onto copper supply pipes.

Note : If cartridges are removed during installation, re-torque to factory specification of 14-16 ft-lbs.

5. Adjust stiffness of stem rotation by tightening or loosening TORQUE NUT. Check stiffness by placing lever handle in horizontal position onto cartridge stem. Handle should not rotate under its own weight.
(Note: Water supply to valve should still be off; water pressure may affect the stiffness of stem.)
6. Solder/Braze end device line to the elbow.

Note: Bath drop connecting to the spout requires a 1/2" NPT fitting at finished wall(not included).

7. Place temporary 3/4" or 1/2" NPT plug(based on spout thread size) into fitting of bath drop (not included).
8. Turn on water supply, pressurize system and check for leaks. Finished wall dimensions are shown in Figure 1A.
9. Install handle escutcheon/bonnet trim and mark the cartridge all-thread nipple where excess needs to be trimmed.
10. Remove handle escutcheon/bonnet trim and cut cartridge all-thread nipple 1/16" less than indicated mark to prevent exposure of nipple threads.

Note: Do not cut stem & all thread nipple until finished wall is complete and a dimensional check of handle and escutcheon/bonnet trim is done.
(Stem is grooved in 1/2" intervals).

11. Cut cartridge stem at least 1/2" past the end of the cut all-thread nipple. Final stem length may vary based on individual handle base configuration.
12. Apply clear silicone sealant to backside of escutcheons. Reinstall escutcheon/bonnet trim and handle.

13. Secure handle into place by tightening handle setscrew.

Note: To achieve desired handle rotational alignment, the Cartridge **MUST** be tightened in clockwise rotation only. **DO NOT** loosen the cartridge. Factory torque of 14 ft-lbs. minimum, must be maintained.

Figure 1

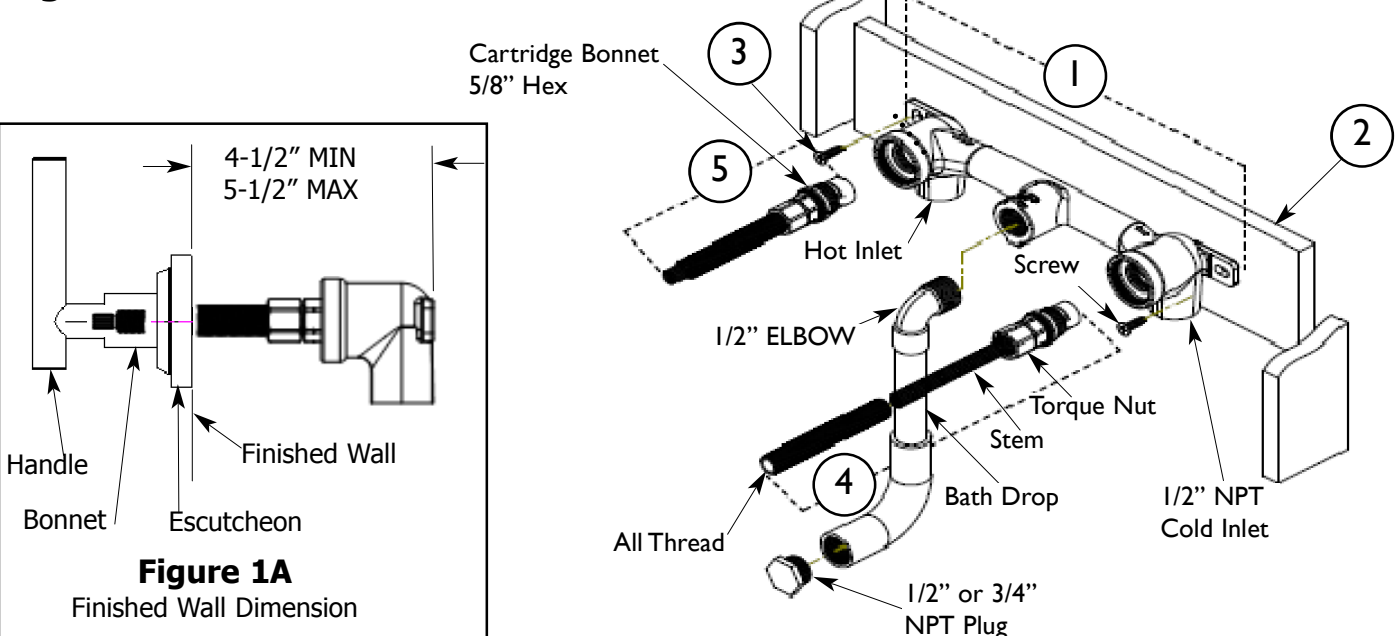

NEWPORT BRASS
Flawless Beauty. From Faucet to Finish.™