

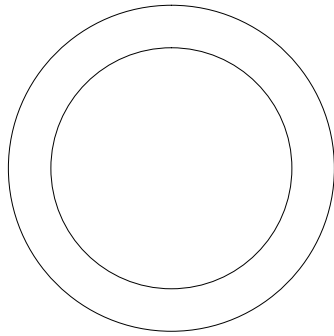

PRODUCT NAME: WAFER LED FLUSH MOUNT  
ITEM NUMBER: 57736  
57737

Please consult a qualified electrician for hanging fixture and wiring.  
**CAUTION:** Before starting the installation, disconnect the power by turning off the circuit breaker or by removing the fuse at the fuse box. Carefully unpack and identify all parts before assembly



This fixture is designed to work with standard Triac forward phase dimmer. Dimming levels will vary by dimmer.

Below is a list of recommended dimmers:

- Lutron MACL-153M
- Lutron DVL-153P
- Lutron SCL-153P
- Leviton IPL06-10Z
- Leviton 6674-POW

Due to inrush current wattage should not exceed 150 Watts of product for a 600 Watt dimmer.

36W AC LED

**CAUTION: 120V-277V INPUT,  
120V DIMMING ONLY.**

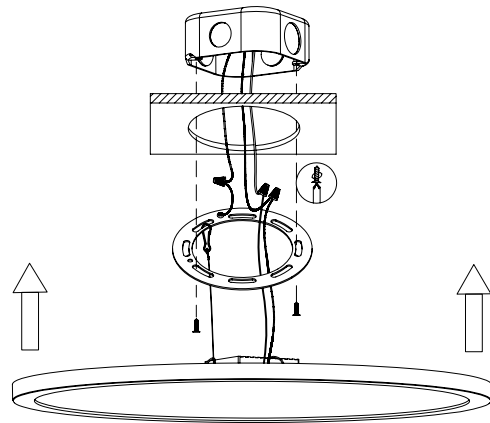

1. Prior to installation, install the mounting plate on the junction box with mounting screws (make sure of engraved letter "OUTWARD" side facing downward). Drive screws completely to the end of the junction box.
2. Connect supply wires to wires on fixture with wire nuts. Connect white to white, black to black and copper wire to copper wire as grounding connection.
3. Completing the installation by pushing the fixture into the mounting plate.