

Features

- KOHLER cast iron
- Acid-resistant enamel finish
- Self-rimming
- Single compartment
- 4-hole (-4), 3-hole (-3), or single-hole (-1)
- 25" (63.5 cm) x 22" (55.9 cm)

SELF-RIMMING KITCHEN SINK K-5964

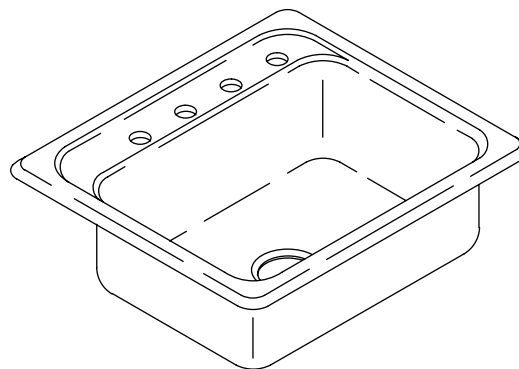

Codes/Standards Applicable

Specified model meets or exceeds the following:

- ASME A112.19.1M
- IAPMO/UPC
- CSA B45

Colors/Finishes

- 0: White
- Other: Refer to Price Book for additional colors/finishes

Accessories:

- CP: Polished Chrome
- NA: None applicable
- Other: Refer to Price Book for additional colors/finishes

Specified Model

Model	Description	Colors/Finishes	
K-5964-4	4-hole sink	<input type="checkbox"/> 0	<input type="checkbox"/> Other_____
K-5964-3	3-hole sink	<input type="checkbox"/> 0	<input type="checkbox"/> Other_____
K-5964-1	Single-hole sink	<input type="checkbox"/> 0	<input type="checkbox"/> Other_____

Recommended Accessories			
K-9000	P-Trap	<input type="checkbox"/> CP	

Optional Accessories			
K-6003	Bottom basin rack	<input type="checkbox"/> 0	<input type="checkbox"/> Other_____
K-6513	Hardwood cutting board	<input type="checkbox"/> NA	
K-8801	Duostrainer® sink strainer	<input type="checkbox"/> CP	<input type="checkbox"/> Other_____

Product Specification

The kitchen sink shall be made of cast iron with acid-resistant enamel finish. Sink shall be self-rimming with a single compartment. Sink shall be 4-hole (-4), 3-hole (-3), or single-hole (-1). Sink shall be 25" (63.5 cm) in length and 22" (55.9 cm) in width. Sink shall be Kohler Model K-5964-_____-_____.

MAYFIELD™

Technical Information

Fixture*:	
Basin area	22" (55.9 cm) x 15" (38.1 cm)
Water depth	7-3/4" (19.7 cm)
Drain hole	3-5/8" (9.2 cm) D.
Faucet holes	1-3/8" (3.5 cm) D.
* Approximate measurements for comparison only.	

Installation Notes

Install this product according to the installation guide.

Cutout is 23-3/4" (60.3 cm) by 20-3/4" (52.7 cm) with 1" (2.5 cm) radius corners.

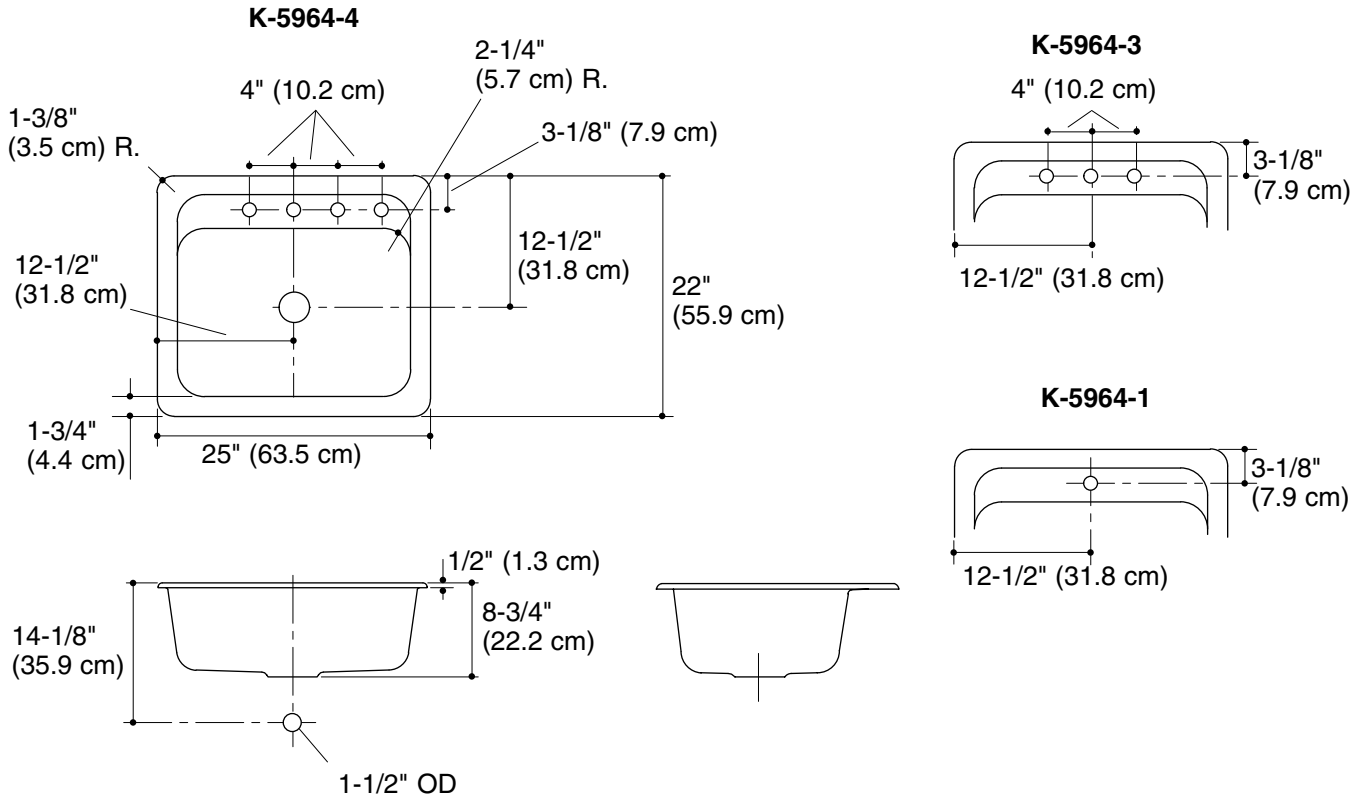

Product Diagram