

# Badger 5®

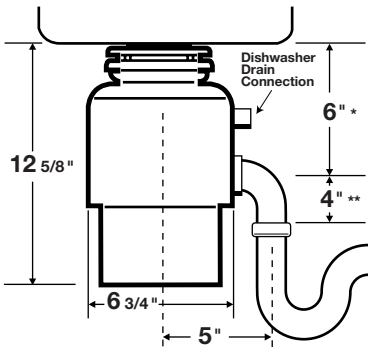

### Dimensions



\*Distance from bottom of sink to center line of disposer outlet. Add 1/2" when stainless steel sinks are used.

\*\*Length of tailpipe from center line of disposer outlet to end of tailpipe.

NOTE: Plumb waste line to prevent standing water in disposer motor housing.

### Job Specifications

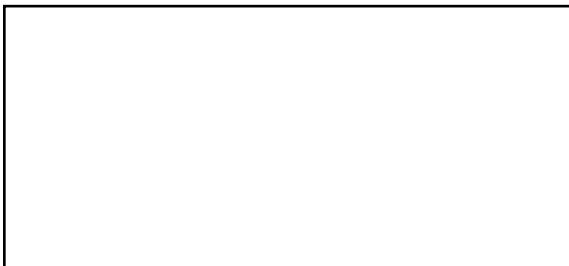

## Submittal Sheet Specifications

This popular model offers you these features and benefits:

- 1/2 Horsepower Heavy Duty Motor (Quiet Dura-Drive® Induction Motor)
- 2-Year *We Come To You*™ In-Home Parts And Labor Service Warranty
- Rugged Galvanized Steel Construction (For Disposer Durability)
- Space-Saving Compact Design

### Sample Specification

Food Waste Disposer(s) shall be In-Sink-Erator Badger 5, continuous feed, with 1/2 H.P. motor, galvanized steel grinding elements with two stainless steel 360° swivel lugs. Self-service wrench. Warranty - 2 year parts and in-home service.

\*The complete In-Sink-Erator warranty is included in the Care & Use Booklet, packed with each unit.

Type of Feed	Continuous
On/Off Control	Wall Switch
Motor	Single Phase
HP	1/2
Volts	120
HZ	60
RPM	1725
Amp. (Avg. Load)	6.9
Time Rating	Intermittent
Lubrication	Permanently Lubricated Upper & Lower Bearings
Shipping Weight (Approx.)	14 lbs. 11 oz.
Unit Finish	Waterborne Grey Enamel
Overall Height	12-5/8"
Grind Chamber Capacity	26 oz.
Motor Protection	Manual reset Overload
Average Water Usage	1/4 Gallon Per Person Per Day
Average Electrical Usage	1/2 KWH Per Month
Drain Connection	1-1/2" Cushioned Slip Joint
Dishwasher Drain Connection	Yes



**EMERSON™**  
Appliance Solutions

The Emerson logo is a trademark and a service mark of Emerson Electric Co. In-Sink-Erator is a division of Emerson Electric Co.