

| BILL OF MATERIAL (CURRENT LEVEL) | | | | |
|----------------------------------|---------|----------------------------------|----------|------|
| ITEM | PT/ASSY | DESCRIPTION | TYPE | QTY. |
| 1 | 1-206 | HARDWARE PACK | ASSEMBLY | 2 |
| 2 | 40567 | SHOWER ROD ROSETTE | PART | 2 |
| 3 | 91073 | O-RING, #2-120, EPDM, 65-75 DURO | PART | 2 |
| 4 | 0239MP | MOUNTING PLATE | PART | 2 |

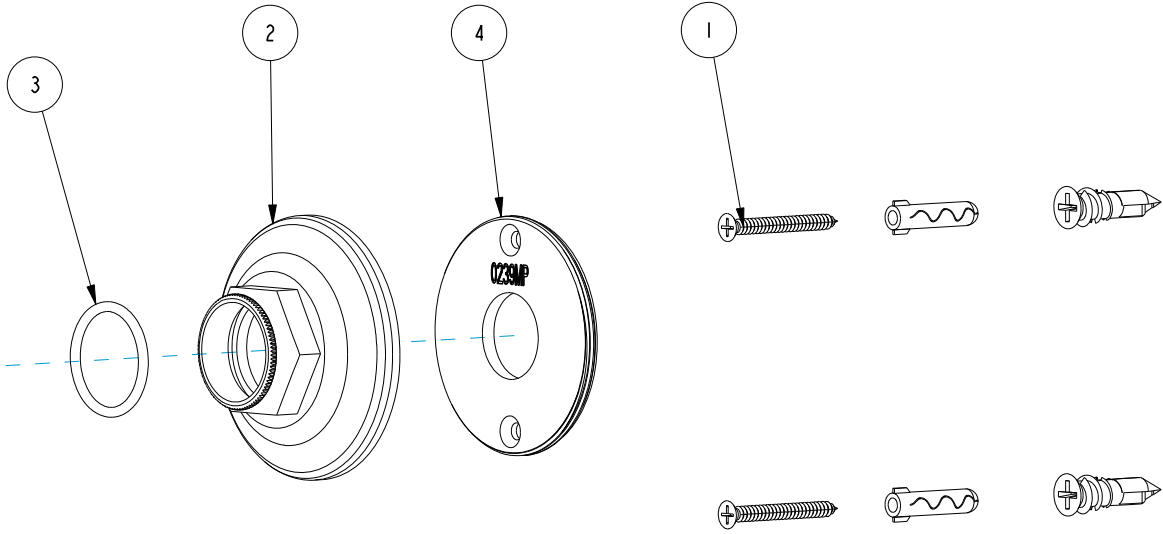

COPYRIGHT 2005 GINGER. THESE DRAWINGS AND THE DESIGNS DEPICTED HEREIN ARE THE PROPRIETARY PROPERTY OF GINGER. ANY USE OR REPRODUCTION IS SUBJECT TO THE EXPRESS APPROVAL OF GINGER. UNAUTHORIZED USE IS STRICTLY PROHIBITED. ALL RIGHTS RESERVED.

GINGER

2001 CARNEGIE AVE.
SANTA ANA CA 92705
(949) 417-5207

SHOWER ROD BRACKETS ONLY, PAIR

| | | | | |
|------------|--------|--------------|---------|---------------|
| ASSY. NO. | | A | EN-2717 | 04/04/14 |
| 4839B | | - | EN-2086 | 09/01/13 |
| SCALE .500 | REF. - | SHEET 1 OF 3 | REV | REV DESC DATE |

SPECIFICATION DWG

PN: 1139R/6
SOLD SEPERATELY

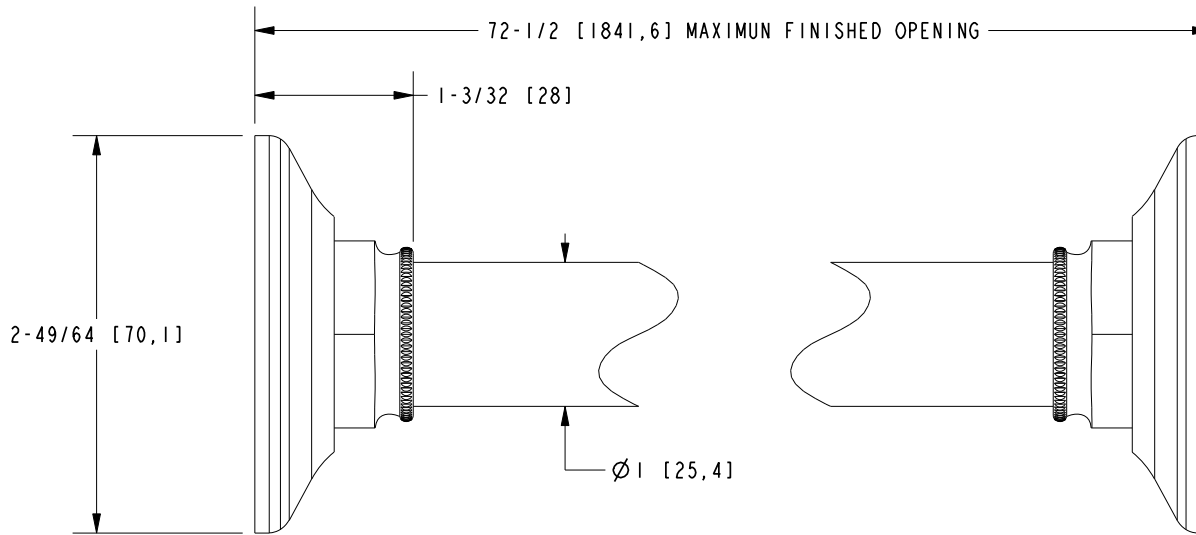
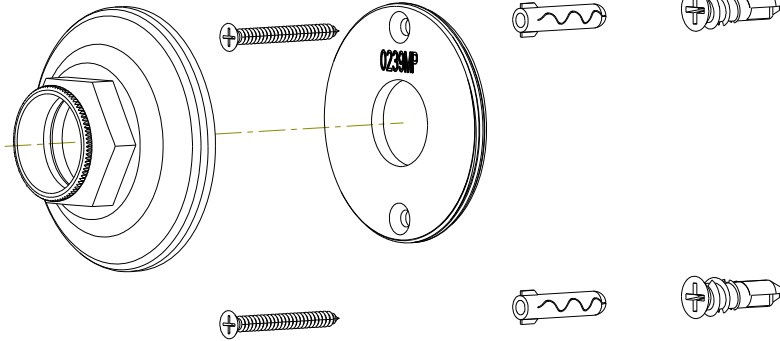

DIMENSIONS ARE IN INCHES AND AN APPROXIMATION OF A TYPICAL INSTALLATION

COPYRIGHT 2005 GINGER. THESE DRAWINGS AND THE DESIGNS DEPICTED HEREIN ARE THE PROPRIETARY PROPERTY OF GINGER. ANY USE OR REPRODUCTION IS SUBJECT TO THE EXPRESS APPROVAL OF GINGER. UNAUTHORIZED USE IS STRICTLY PROHIBITED. ALL RIGHTS RESERVED.

| | | | |
|---------------|-------|--|---|
| GINGER | | 2001 CARNEGIE AVE. SANTA ANA CA 92705 (949) 417-5207 | |
| DWG NO. | 4839B | REV | A |
| SCALE | .750 | REF. | - |
| SHEET 2 | | OF 3 | |

SPECIFICATION DWG

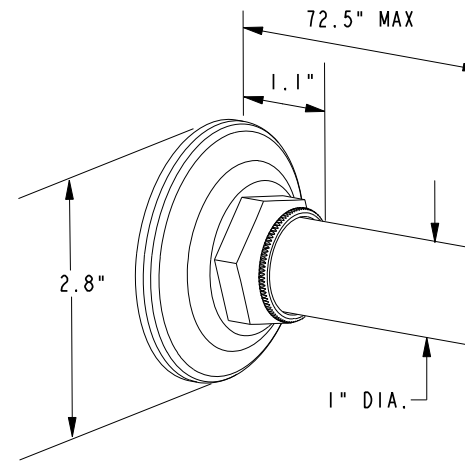

DIMENSIONS ARE IN INCHES AND AN APPROXIMATION OF A TYPICAL INSTALLATION

COPYRIGHT 2005 GINGER. THESE DRAWINGS AND THE DESIGNS DEPICTED HEREIN ARE THE PROPRIETARY PROPERTY OF GINGER. ANY USE OR REPRODUCTION IS SUBJECT TO THE EXPRESS APPROVAL OF GINGER. UNAUTHORIZED USE IS STRICTLY PROHIBITED. ALL RIGHTS RESERVED.

| | | | |
|---------------|-------|--|---|
| GINGER | | 2001 CARNEGIE AVE. SANTA ANA CA 92705 (949) 417-5207 | |
| DWG NO. | 4839B | REV | A |
| SCALE | .500 | REF. | - |
| SHEET 3 | | OF 3 | |