

NOTE:

1. BAG ITEMS 1 AND 3. ASSEMBLE ALL REMAINING ITEMS.

**BILL OF MATERIAL (CURRENT LEVEL)**

ITEM	PT/ASSY	DESCRIPTION	TYPE	QTY.
1	1-206	HARDWARE PACK	ASSEMBLY	1
2	92422	HEX KEY, 1/8" ALLOY STEEL (MMC# 7122A18)	PART	1
3	92437	MOUNTING BRACKET	PART	1
4	40418	OPEN TISSUE HOLDER POST	PART	1
5	92495	SCRW, 1/4-28 x 3/8" CUP POINT SET SS (MMC # 92311A558)	PART	1

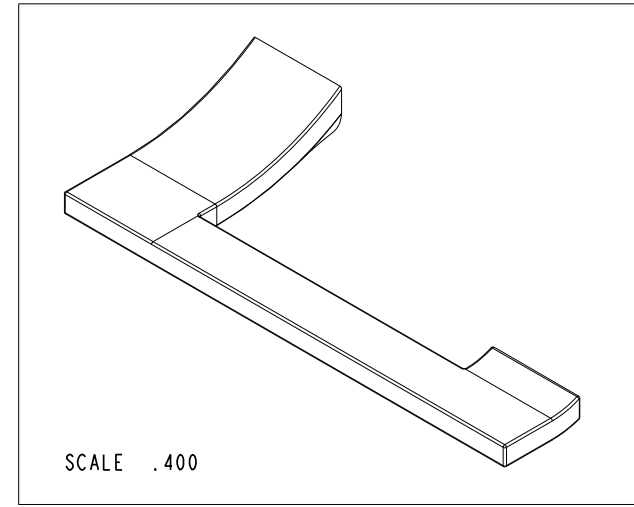
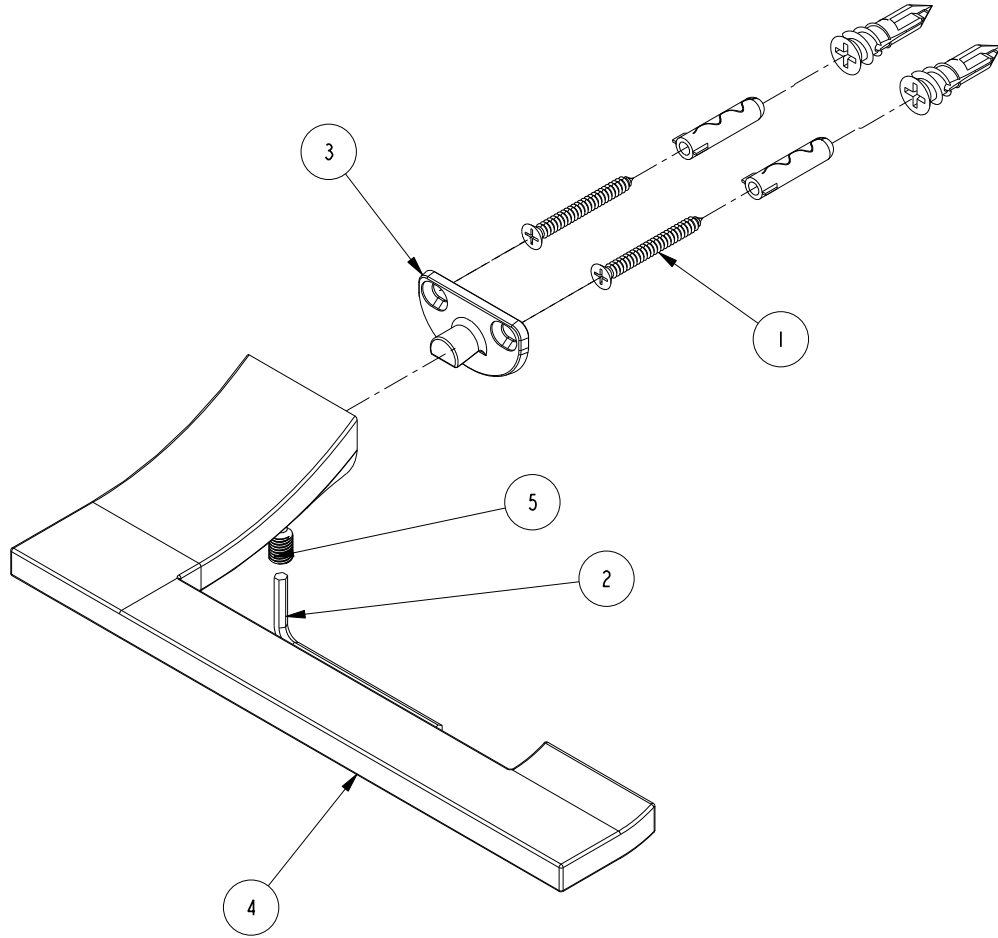

COPYRIGHT 2005 GINGER. THESE DRAWINGS AND THE DESIGNS DEPICTED HEREIN ARE THE PROPRIETARY PROPERTY OF GINGER. ANY USE OR REPRODUCTION IS SUBJECT TO THE EXPRESS APPROVAL OF GINGER. UNAUTHORIZED USE IS STRICTLY PROHIBITED. ALL RIGHTS RESERVED.

**GINGER**

2001 E. CARNEGIE AVE.  
SANTA ANNA CA 92705  
(949) 417-5207

TISSUE HOLDER

ASSY. NO. **4706**

SCALE .500

REF. -

SHEET 1 OF 2

B	EN-1718	04/01/11
A	EN-1701	02/17/11
-	EN-1294	11/09/10
REV	REV DESC	DATE

SPECIFICATION DWG

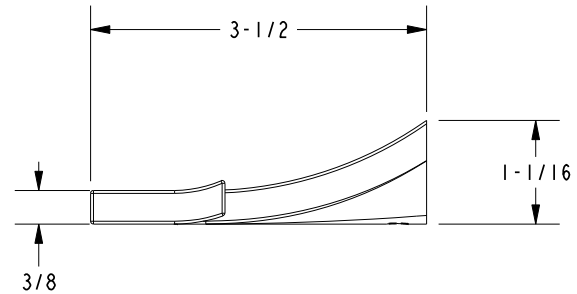
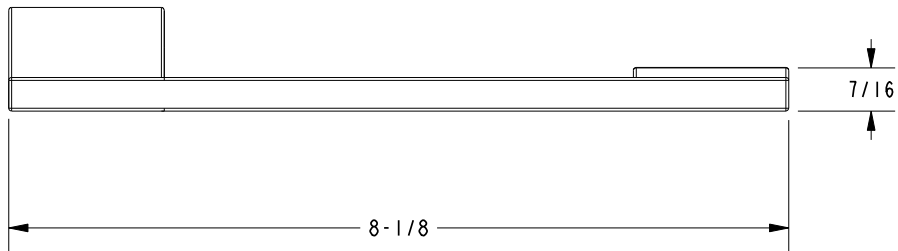
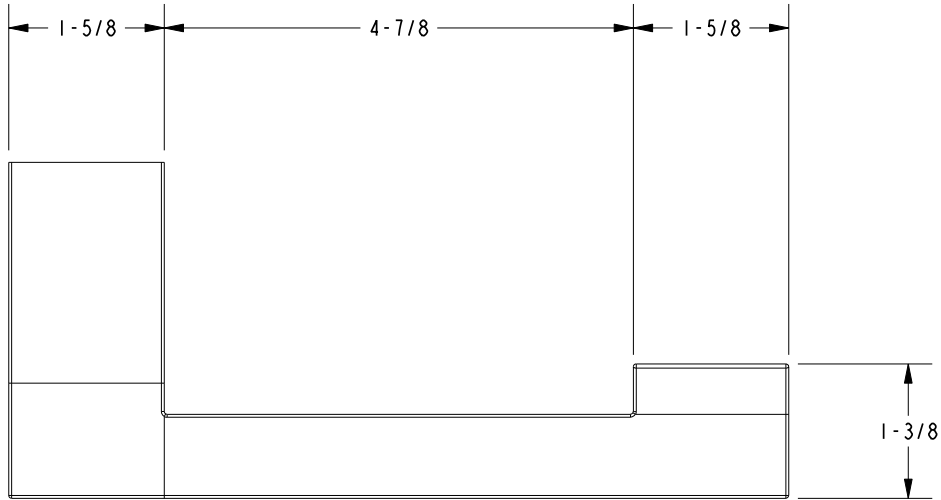

DIMENSIONS ARE IN INCHES AND AN APPROXIMATION OF A TYPICAL INSTALLATION

COPYRIGHT 2005 GINGER. THESE DRAWINGS AND THE DESIGNS DEPICTED HEREIN ARE THE PROPRIETARY PROPERTY OF GINGER. ANY USE OR REPRODUCTION IS SUBJECT TO THE EXPRESS APPROVAL OF GINGER. UNAUTHORIZED USE IS STRICTLY PROHIBITED. ALL RIGHTS RESERVED.

<b>GINGER</b>		2001 E. CARNEGIE AVE. SANTA ANNA CA 92705 (949) 417-5207	
DWG NO.	4706	REV	B
SCALE	.500	REF.	-
		SHEET	2 OF 2