

BILL OF MATERIAL

ITEM	PT/ASSY	DESCRIPTION	TYPE	QTY.	DWG.NO.
1	45XX	MOUNTING FLANGE	PART	2	45A-002
2	4500	ROSETTE	PART	2	45A-003
3	SM5-5S	M5 x5 STAINLESS STEEL SET SCREW	PART	2	-
4	8_1_5PFZ	NO.8 x 1-1/2" PHILLIPS FLAT HEAD	PART	4	-
5	GCA	NO. 8 -10 WALL ANCHOR PLASTIC	PART	4	-
6	SSPM	DRYWALL ANCHOR	PART	4	-
7	M2_5HK	2.5MM ALLOY STEEL HEX KEY	PART	1	-
8	4522P	DOUBLE TOWEL BAR POST	PART	2	45A-009
9	4534F	SHELF FINIAL	PART	2	45A-014
10	0234W	SHELF WASHER	PART	4	SIN-011
11	4534T_24TSCL	SHELF GLASS	PART	1	45A-015
12	0234S	TOP SCREW	PART	2	SIN-011

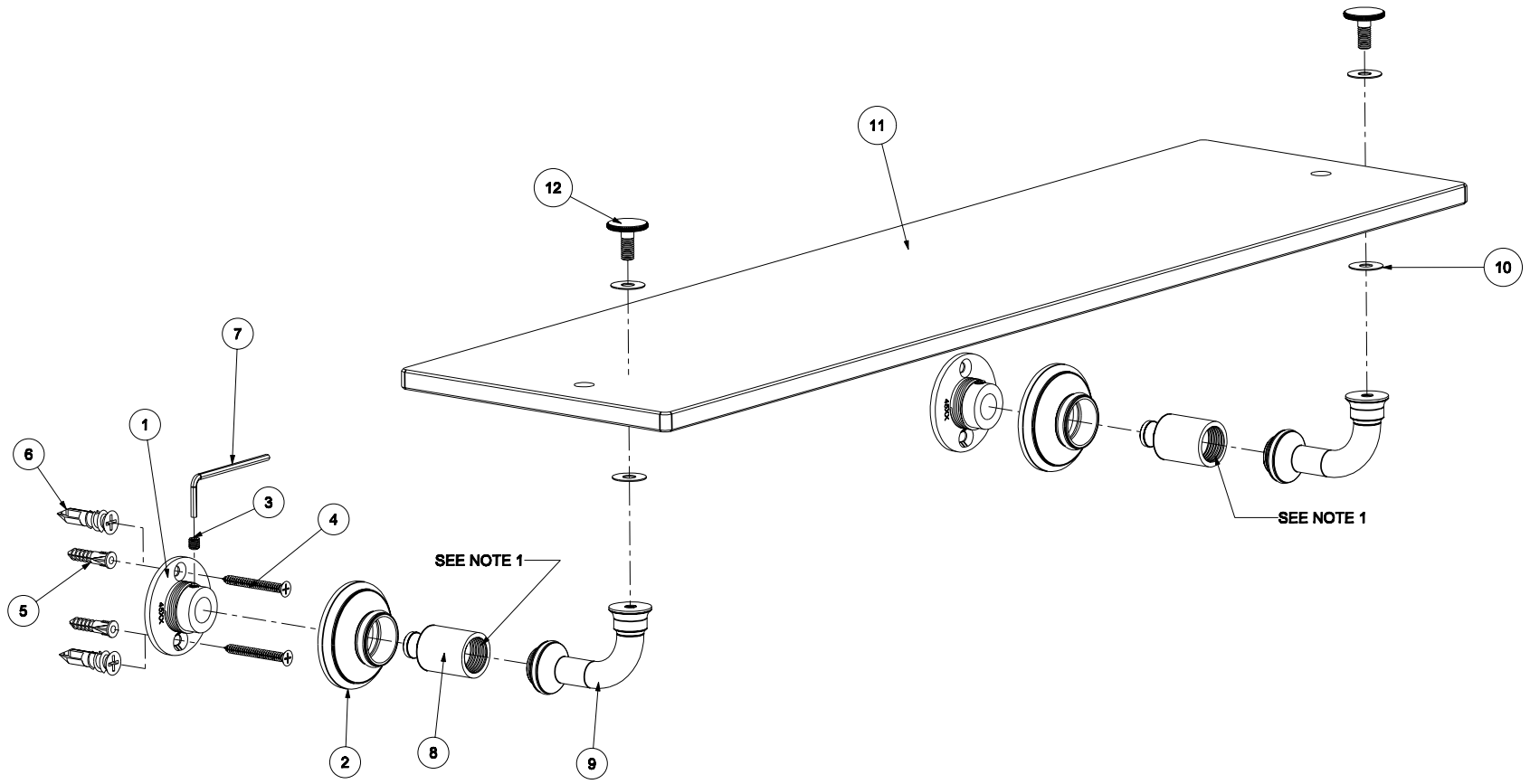

ASSEMBLY NOTES:
 1. APPLY PERMANENT THREAD LOCKER (LOCTITE 262).

FINISHES:AGD- ANTIQUE GOLD, AS- ANTIQUE SILVER , 10B- OIL RUBBED BRONZE,14- POLISHED NICKEL, 15- SATIN NICKEL, 26 POLISHED CHROME					GINGER
MATERIAL: STAINLESS MOUNTING HARDWARE, VARIOUS BRASSES					
PART NO.	4534T/24	24" TRADITIONAL SHELF			
DATE:	7.16.07	REV.DATE	REV.A	SCALE 5:16	COLUMNAR
					DWG.NO. 4534T-24

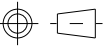
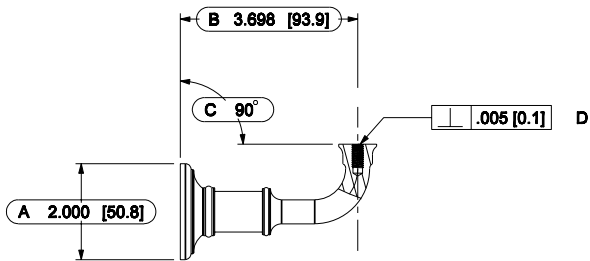
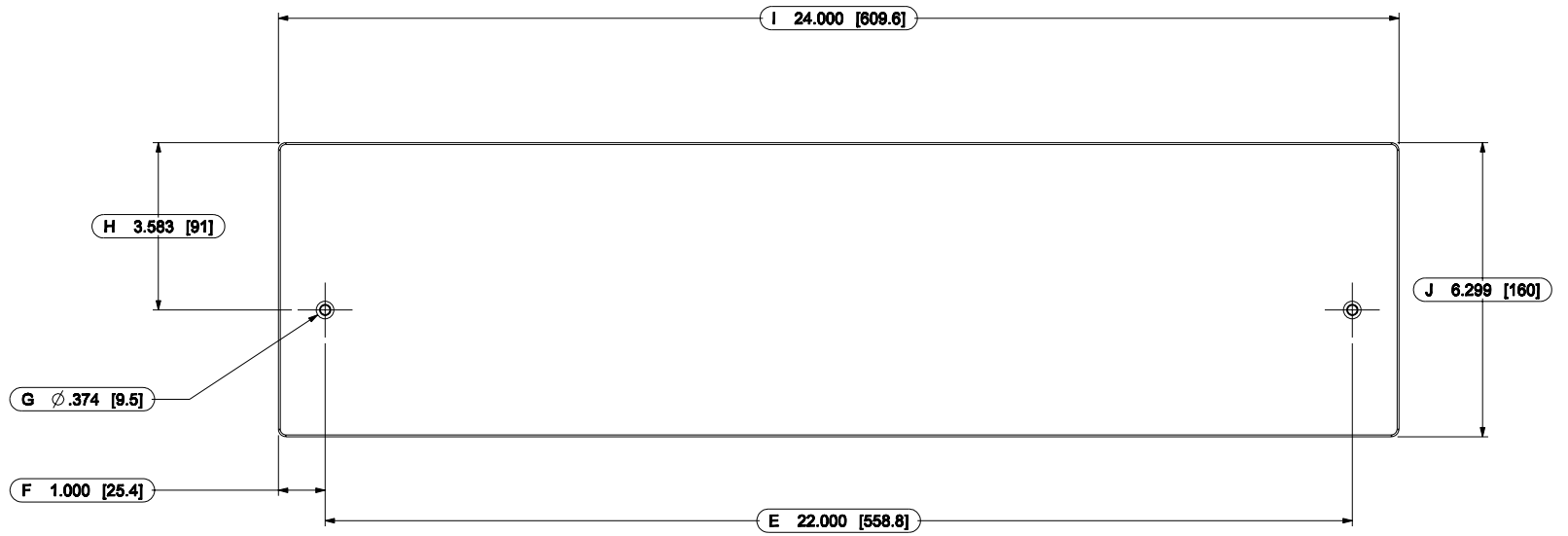

FINISHES:AGD- ANTIQUE GOLD, AS- ANTIQUE SILVER, 10B- OIL RUBBED BRONZE,14- POLISHED NICKEL, 15- SATIN NICKEL, 26 POLISHED CHROME					GINGER
MATERIAL: STAINLESS MOUNTING HARDWARE, VARIOUS BRASSES					
PART NO.	4534T/24	24" TRADITIONAL SHELF			DWG.NO.
DATE:7.16.07	REV.DATE	REV.A	SCALE 1:4	COLUMNAR	4534T-24