

**INSTALLATION
INSTRUCTIONS**

**TU722500
TU722501
TU722502
TU722507
TU722508**

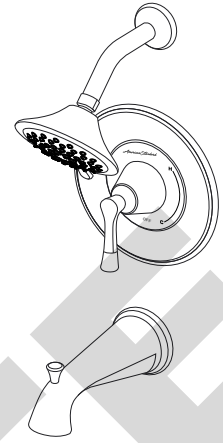

**Estate®
Pressure Balancing
Bath and Shower Trim Kit**

Thank you for selecting American Standard...
the benchmark of fine quality for over 100 years.

To ensure that your installation proceeds smoothly-please
read these instructions carefully before you begin.

For use with shower heads rated at 4.9 L/min (1.3 gpm) or higher.

RECOMMENDED TOOLS

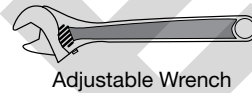
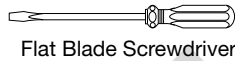
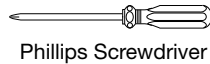

ROUGHING-IN DIMENSIONS

- To assure proper positioning in relation to wall.
Note roughing-in dimensions.

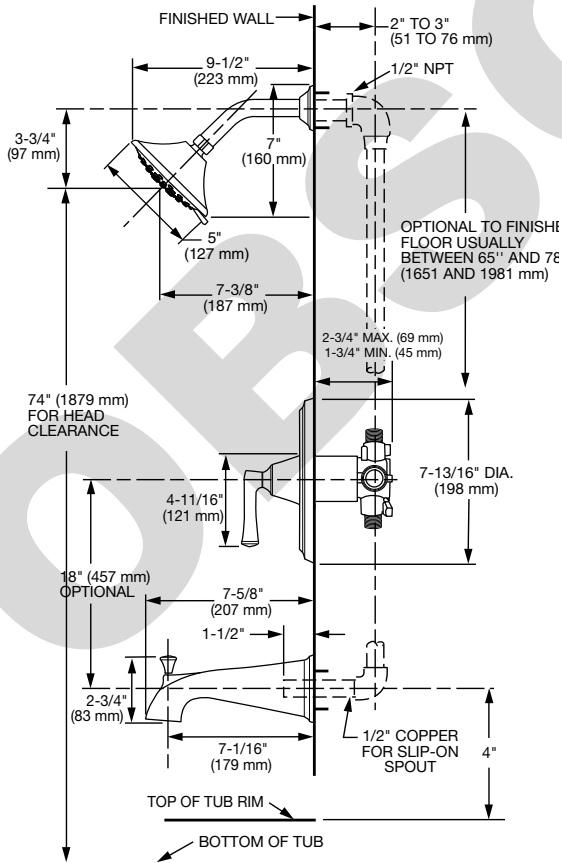

1 CARTRIDGE INSTALLATION

- Remove **PLASTER GUARD (6)**
(Keep it installed for thin wall Installation).
- Remove **BONNET NUT (1)** by unthreading it
Counter clockwise. Remove test **CAP (2)**.
- Remove **PROTECTIVE HOUSING (3)** from
CARTRIDGE (4). Install with "UP" text on top.
- Reinstall **BONNET NUT (1)** onto **VALVE BODY (5)**
and tighten firmly with 12 Nm or 9 lbs/ft.

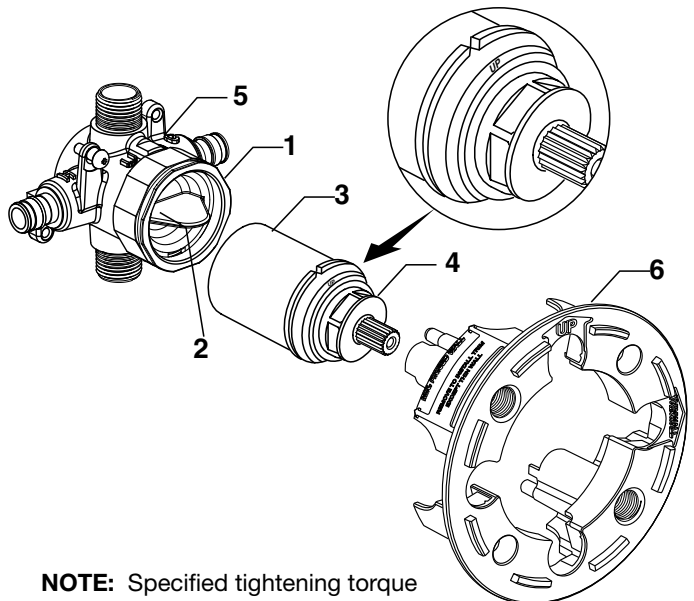

NOTE: Specified tightening torque
of **BONNET NUT (1)** is critical to
assure sealing function.

2 STANDARD WALL INSTALLATION

- **Figure 1.** Remove plaster guard from valve. Push CAP (1) over VALVE CARTRIDGE (2) until seated against stop.
- **Figure 2.** Push ESCUTCHEON (3) onto CAP (1) and attach to valve body with LONG SCREWS (4).

THIN WALL INSTALLATION

- **Figure 1a.** Push CAP (1) over VALVE CARTRIDGE (2) until seated against stop.
- **Figure 2a.** Push ESCUTCHEON (3) onto CAP (1) and attach to valve body with LONG SCREWS (4).

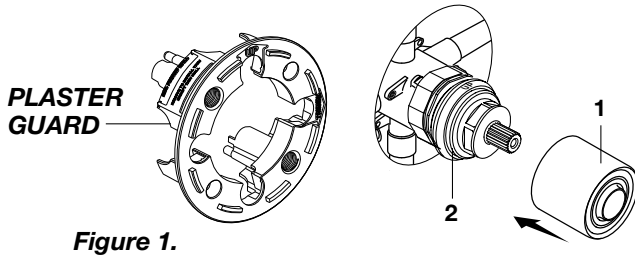

Figure 1.

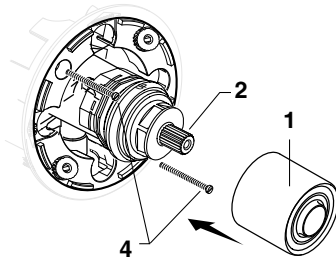

Figure 1a.

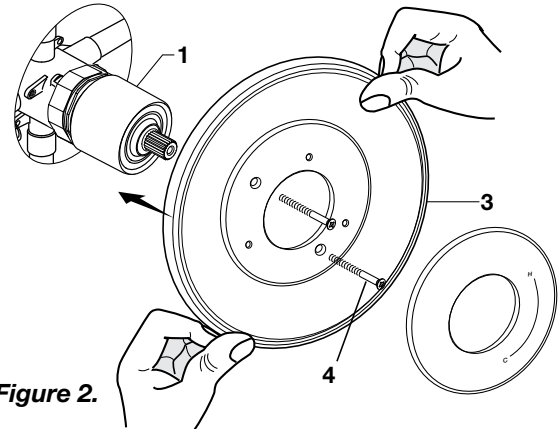

Figure 2.

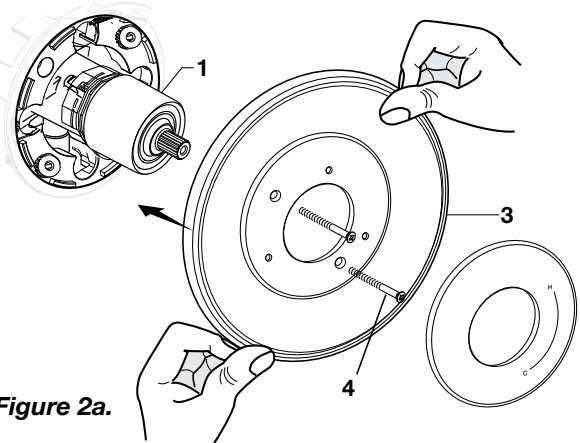
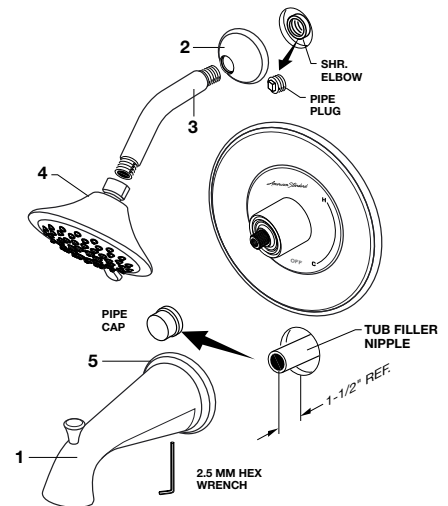

Figure 2a.

3 INSTALL TUB SPOUT, SHOWER HEAD, SHOWER ARM WITH FLANGE

CAUTION Protect finish on SHOWER HEAD and TUB SPOUT when installing.

- Remove pipe cap and plug from shower and tub rough piping.
- Slip DECORATIVE PLATE (5), then slip TUB SPOUT (1) onto tub nipple and tighten with 4mm Hex Wrench.
- **CAUTION: Protect finish on TUB SPOUT when installing.**
- Install SHOWER ESCUTCHEON (2) onto SHOWER ARM (3). Apply sealant or Teflon tape to threads on both ends of SHOWER ARM (3) and thread longer leg of SHOWER ARM (3) into shower elbow.
- Thread SHOWER HEAD (4) onto SHOWER ARM (3).
- **CAUTION: Protect finish on SHOWER HEAD and ARM when installing.**



4 HANDLE INSTALLATION

- Install HANDLE (1) by pushing it onto CARTRIDGE STEM (2) and tightening SET SCREW (3) from below with 2.5 mm Hex Wrench supplied.

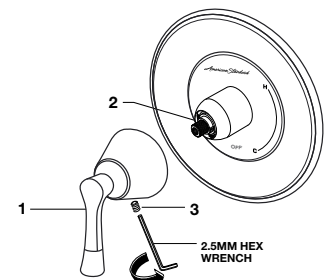

5 ADJUST HOT LIMIT STOP

- By restricting HANDLE rotation and limiting the amount of hot water allowed to mix with the cold, the HOT LIMIT SAFETY STOP (1) reduces risk of accidental scalding. To set the maximum hot water temperature of your faucet valve, adjust the setting on the HOT LIMIT SAFETY STOP (1).
- Turn CARTRIDGE STEM (2) to the OFF position (coldest setting) before making adjustment to HOT LIMIT STOP (1). Pull forward and rotate counterclockwise one number to limit hot water temperature. Use NUMBERS (5) on CARTRIDGE (4) on HOT LIMIT STOP (1) for indication.

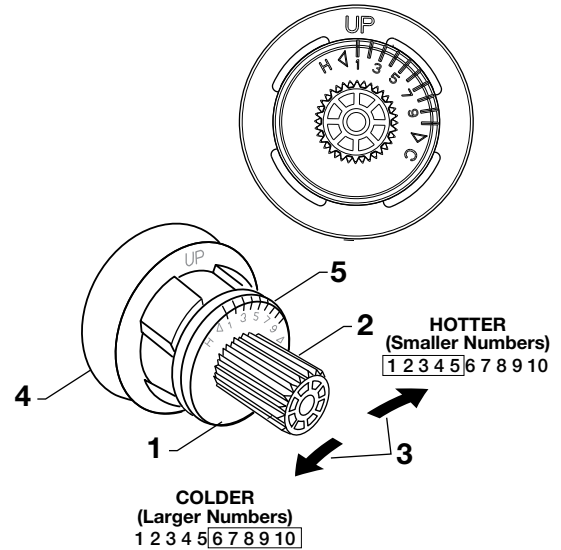

6 SERVICE

TO GAIN ACCESS TO VALVE FOR SERVICING

CAUTION Turn off hot and cold water supplies before beginning.

- Remove HANDLE (see step 3 and reverse).
- Remove ESCUTCHEON and CARTRIDGE CAP (see step 1 and reverse).

VALVE LEAKS WHEN SHUT OFF

- Remove CARTRIDGE, see STEP 1 and STEP 2 and REVERSE process.
- Clean SEALS on the side of CARTRIDGE. Clean inside sealing surface of VALVE BODY.
- Re-assemble CARTRIDGE. Install trim. Turn on water supply and check for leaks.

REPLACING CARTRIDGE

- To remove CARTRIDGE (1), install split WASHER (3) between the ridge on the cartridge and the bonnet nut. (only supplied with replacement cartridge). as shown.
- Proceed to unthread BONNET NUT (2) counter clockwise.
Note: CARTRIDGE (1) should be pulling out while unthreading BONNET NUT (2).
- Upon removal of the old Cartridge, install a new cartridge and secure it with BONNET NUT (Hand tighten).

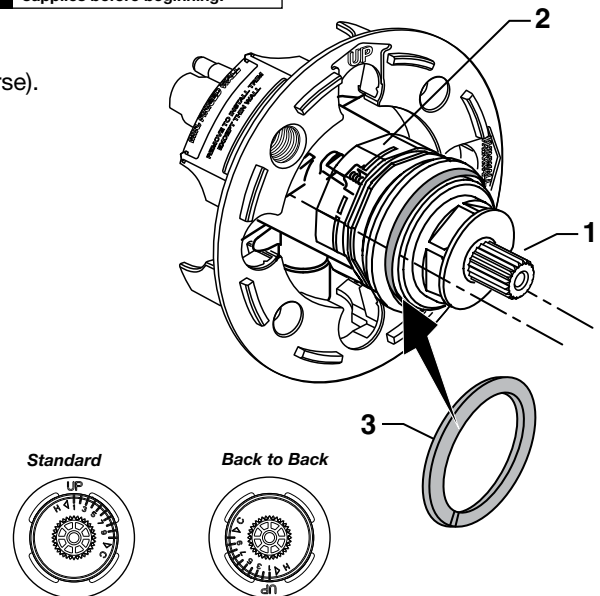

BACK TO BACK INSTALLATION

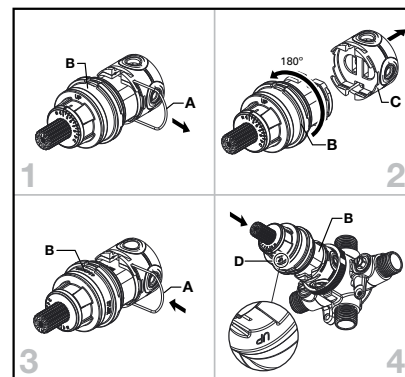

7 CARE INSTRUCTIONS:

DO: SIMPLY RINSE THE PRODUCT CLEAN WITH CLEAR WATER. DRY WITH A SOFT COTTON FLANNEL CLOTH.

DO NOT: DO NOT CLEAN THE PRODUCT WITH SOAPS, ACID, POLISH, ABRASIVES, HARSH CLEANERS, OR A CLOTH WITH A COARSE SURFACE.

American Standard

Estate® Pressure Balancing Bath and Shower Trim Kit

MODEL NUMBER

TU722500
TU722501
TU722502
TU722507
TU722508

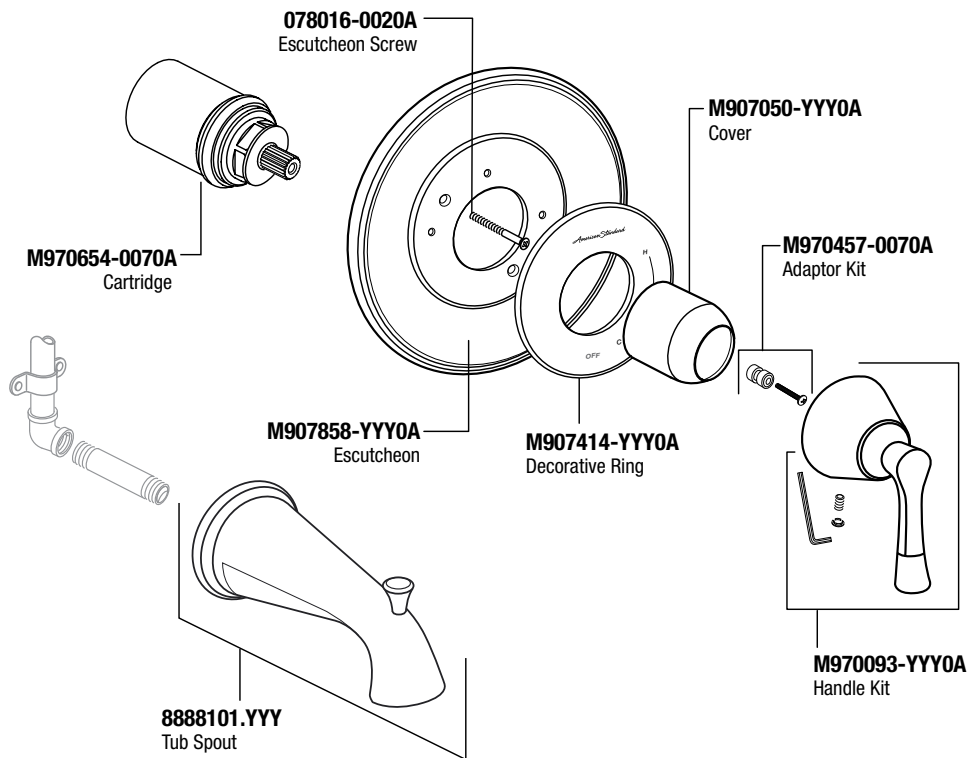
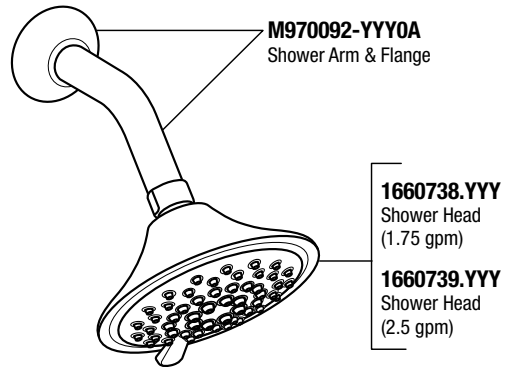

PURCHASE SEPARATELY

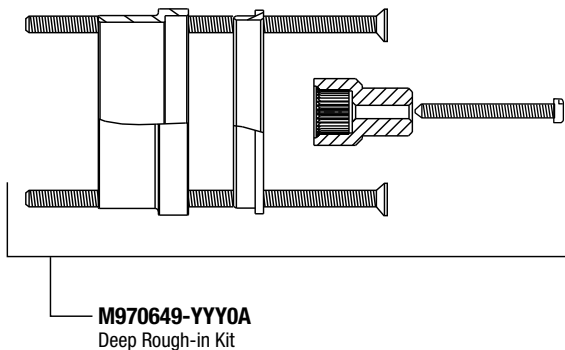

Replace the "YYY" with appropriate finish code

POLISHED CHROME	002
POLISHED NICKEL	013
LEGACY BRONZE	278
BRUSHED NICKEL	295

HOT LINE FOR HELP

For toll-free information and answers to your questions, call:
1 (800) 442-1902

Mon. - Fri. 8:00 a.m. to 8:00 p.m. EST

Saturday 10:00 a.m. to 4:00 p.m. EST

IN CANADA 1-800-387-0369

(TORONTO 1-905-306-1093)

Weekdays 8:00 a.m. to 7:00 p.m. EST

IN MEXICO 01-800-839-1200



PART OF **LIXIL**