

Installation Instructions

METERING Center Set Faucets

1340.225
1340.255
1340.265
1340.227
1340.267



1340.225
1340.227

1340.255
1340.267

1340.265

Thank you for selecting American-Standard...the benchmark of fine quality for over 100 years.

To ensure that your installation proceeds smoothly—please read these instructions carefully before you begin.

Certified to comply with ANSI A112.18.1

M968493 REV.1.2

Recommended Tools



Tubing Cutter



Channel Locks



Adjustable Wrench

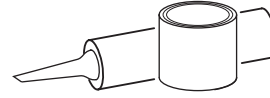

Plumbers' Putty or Caulking

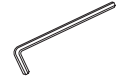

2.5mm Hex Wrench

1 INSTALL FAUCET

CAUTION

Turn off hot and cold water supplies before beginning.

- Apply a bead of PUTTY along the edge of the underside of the FAUCET (1).
- Insert faucet SHANKS through holes of SINK or MOUNTING SURFACE.
- Install GASKET (2), FRICTION WASHER (3), DEEP WASHER (4) and LOCK NUT (5) onto SHANKS (6).
- Tighten LOCK NUTS (5) firmly to secure FAUCET (1).

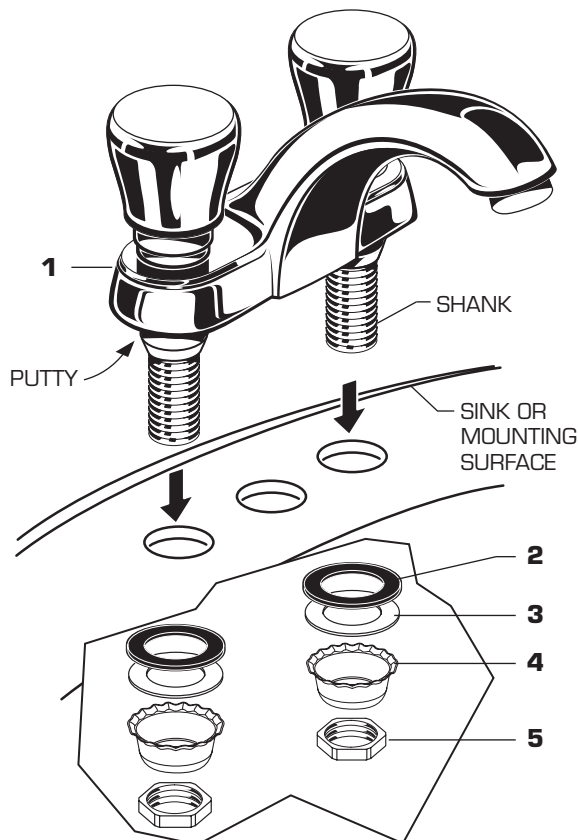

2 MAKE WATER SUPPLY CONNECTIONS

NOTE: FLEXIBLE SUPPLIES OR BULL-NOSE RISERS MUST BE PURCHASED SEPARATELY.

- Connect water supply to FAUCET (1) with 1/2" IPS FLEXIBLE SUPPLIES (1) or 3/8" O.D. BULL-NOSE RISERS (2).
- Use adjustable wrench to tighten connections. Do not over tighten. Be careful not to kink copper supply when bending. Use tubing cutter to cut to proper length.

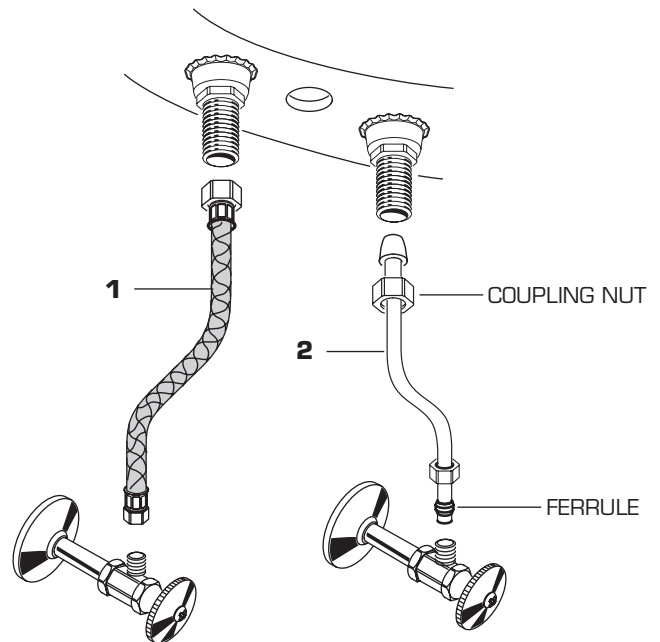

3 TEST INSTALLED FITTING

- Turn on water supplies and check connections for leaks. ➔
- Remove AERATOR (1) with KEY (2) supplied.
- Operate HOT and COLD HANDLES by pressing down on HANDLES. Both Hot and Cold handles are set for approximately 8 second operating cycles.
- Replace AERATOR (1).

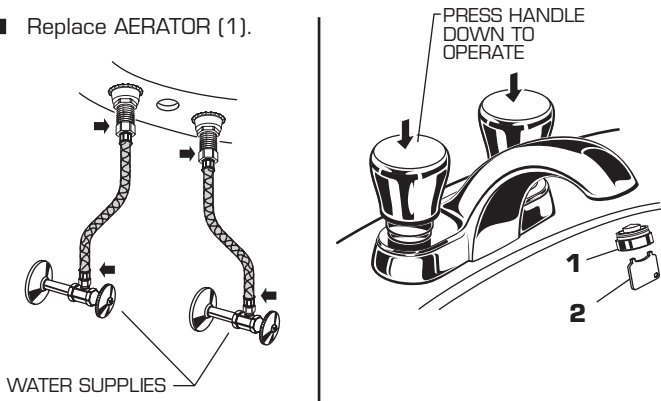

4 TO ADJUST CYCLE TIME

- Remove HANDLE (1) by removing INDEX BUTTON (2) and SET SCREW (3) with a 2.5mm hex wrench.
- Pull off HANDLE (1).
- To increase cycle time, turn the gray PLASTIC ADJUSTING NUT (4) **clockwise**.
- To decrease cycle time, turn the gray PLASTIC ADJUSTING NUT (4) **counter-clockwise**.
- Replace SET SCREW (3), INDEX BUTTON (2) and HANDLE (1). Test faucet for proper operation and cycle time.

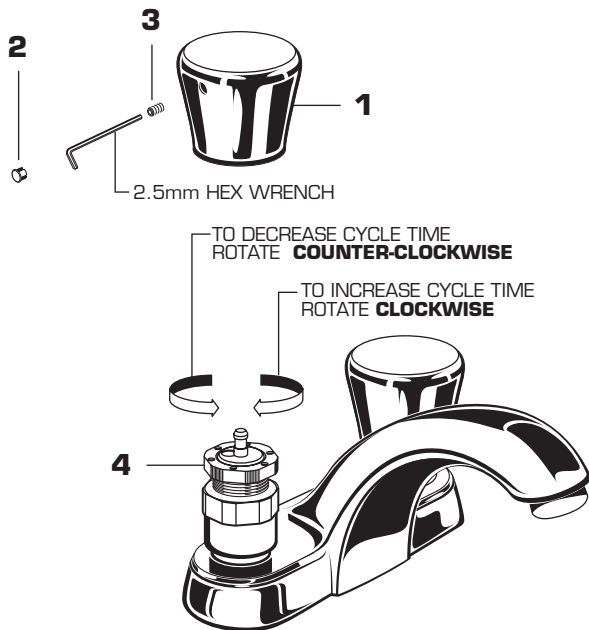

CARE INSTRUCTIONS:

DO: SIMPLY RINSE THE PRODUCT CLEAN WITH CLEAR WATER. DRY WITH A SOFT COTTON FLANNEL CLOTH.

DO NOT: CLEAN THE PRODUCT WITH SOAPS, ACID, POLISH, ABRASIVES, HARSH CLEANERS, OR A CLOTH WITH A COARSE SURFACE.

5 SERVICE

- Remove HANDLE (1). Refer to Step 4 for handle removal.
- Remove ACTUATOR ASSEMBLY (2).
- Remove WASHER (3). Pull out VALVE ASSEMBLY (4) and FILTER SCREEN (5).
- Inspect that VALVE ASSEMBLY (4), FILTER SCREEN (5) and VALVE SEAT (6) are clean and free from debris. VALVE ASSEMBLY (3) and FILTER SCREEN (5) can be cleaned with soap and water.
- Replace FILTER SCREEN (5) and VALVE ASSEMBLY (4). Place WASHER (3) on top of VALVE ASSEMBLY (4). Thread VALVE ACTUATOR (2) onto faucet. Torque VALVE ACTUATOR (2) to 12-15 ft. lbs (15-20 Nm).
- Replace HANDLE (1).

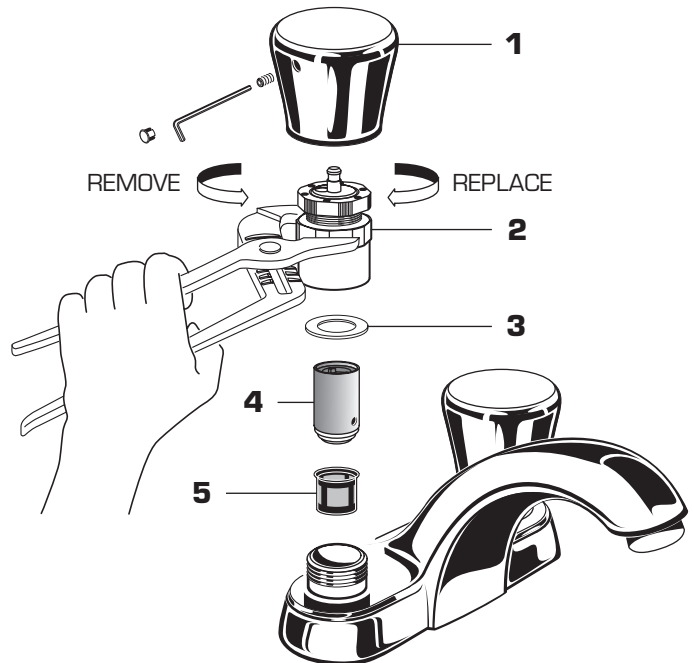

6 CONVERT RIGID SPOUT TO SWIVEL SPOUT (1340.255; 1340.265)

- Unthread SPOUT NUT (1) and remove SPOUT (2).
- Remove SPOUT CLIP (3) and O-RINGS (4).
- Replace RUBBER RING (5) with separate PLASTIC RING (6) supplied with faucet.
- Replace SPOUT CLIP (3) and O-RINGS (4).
- Reassemble SPOUT (2) TO BODY.

