

Installation

Installation

Instalación

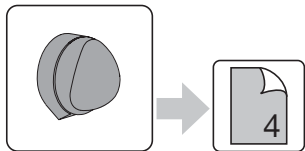
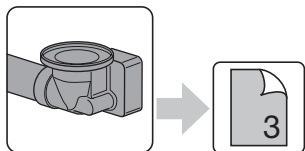
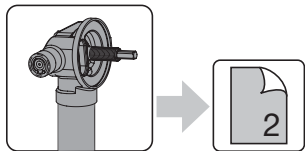
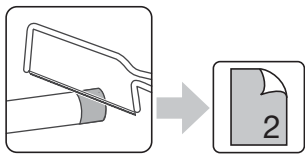
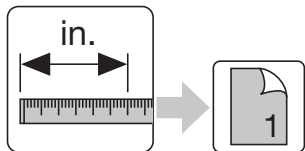
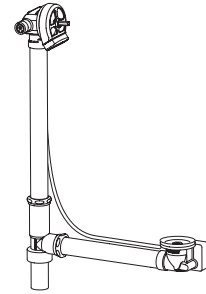

Do not submerged in concrete or other material.
Damage to unit may occur

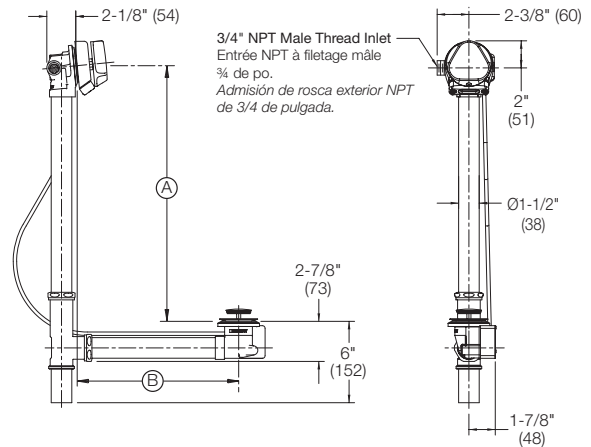

(B) Drain Shoe Length (inches/mm)
Longueur du coude de vidange (pouces/mm)
Longitud de la zapata de drenaje (pulgadas/mm)

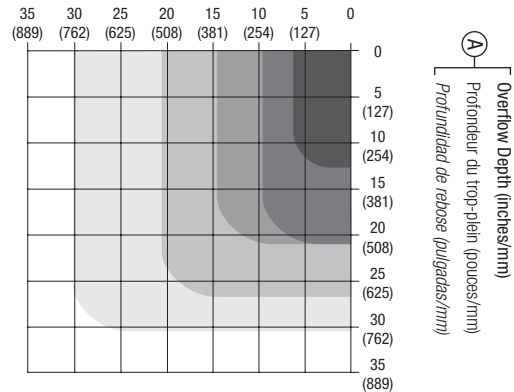

Standard Modular Unit Cable Lengths (inches/mm)

Longueurs du câble de l'unité modulaire standard (pouces/mm)

Longitudes estándar de cable de unidad modular (pulgadas/mm)

Key	Cable Length	A	B	Typical Tub Depth
Légende	Longueur du câble	Profondeur de bain habituelle		
Clave	Longitud del cable	Profundidad común de la tina		
■	17" (432)	12.75" (320)	6.25" (157)	12"-16" (301-402)
■	27" (678)	21.00" (527)	9.50" (238)	17"-24" (427-602)
■	33" (828)	21.00" (527)	14.50" (364)	17"-24" (427-602)
■	43" (1,079)	26.75" (671)	20.50" (515)	25"-29" (628-728)
■	59" (1,481)	30.50" (766)	30.00" (753)	30" (753)

Installation

Installation

Instalación

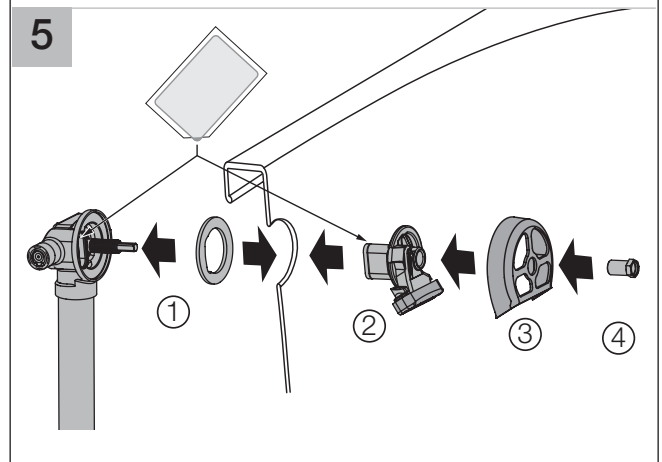
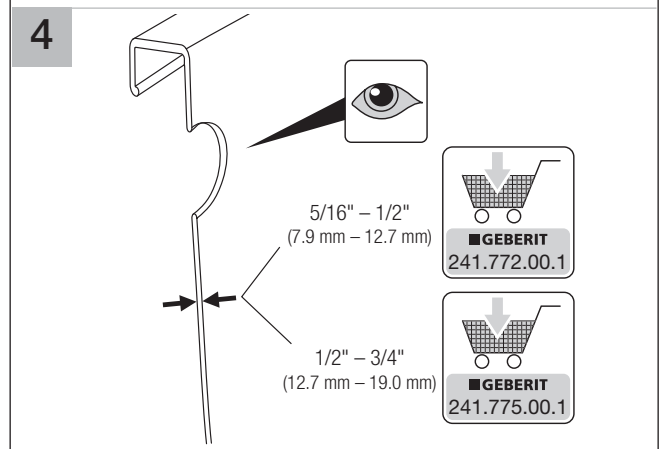
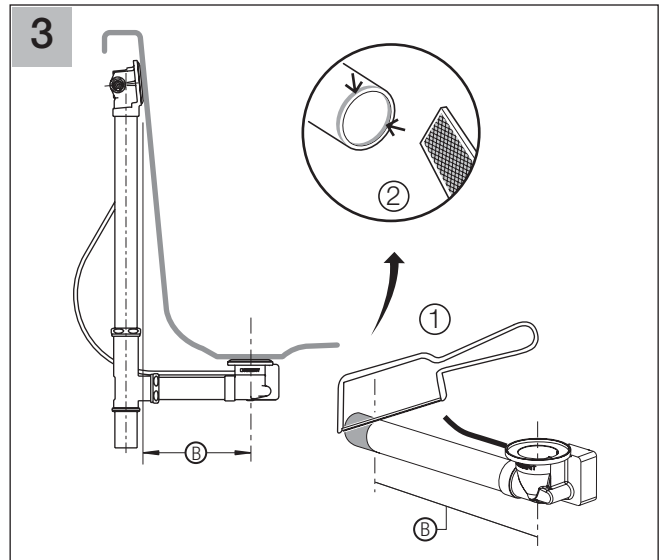
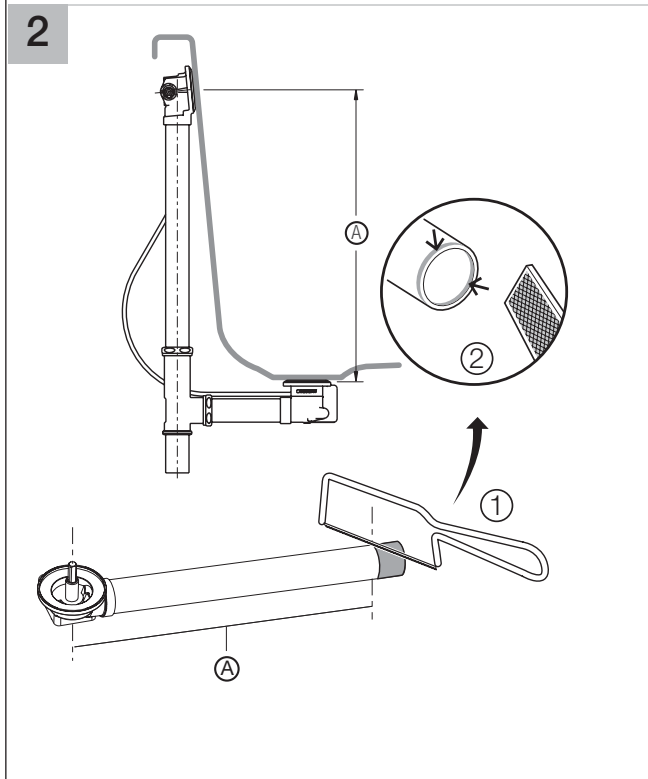
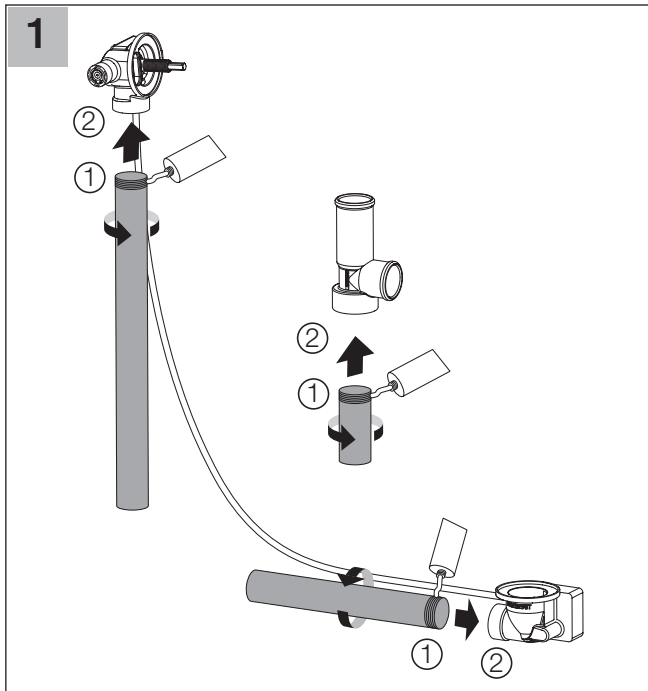

Installation

Installation

Instalación

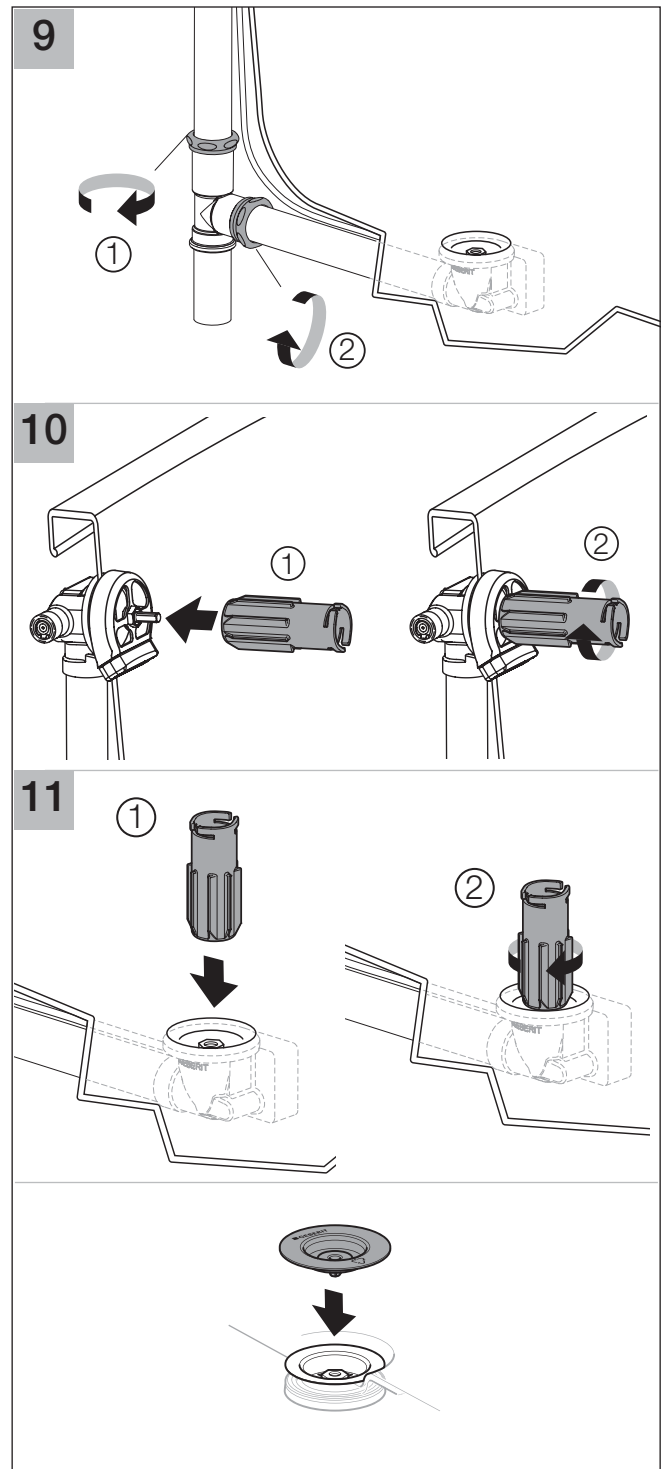
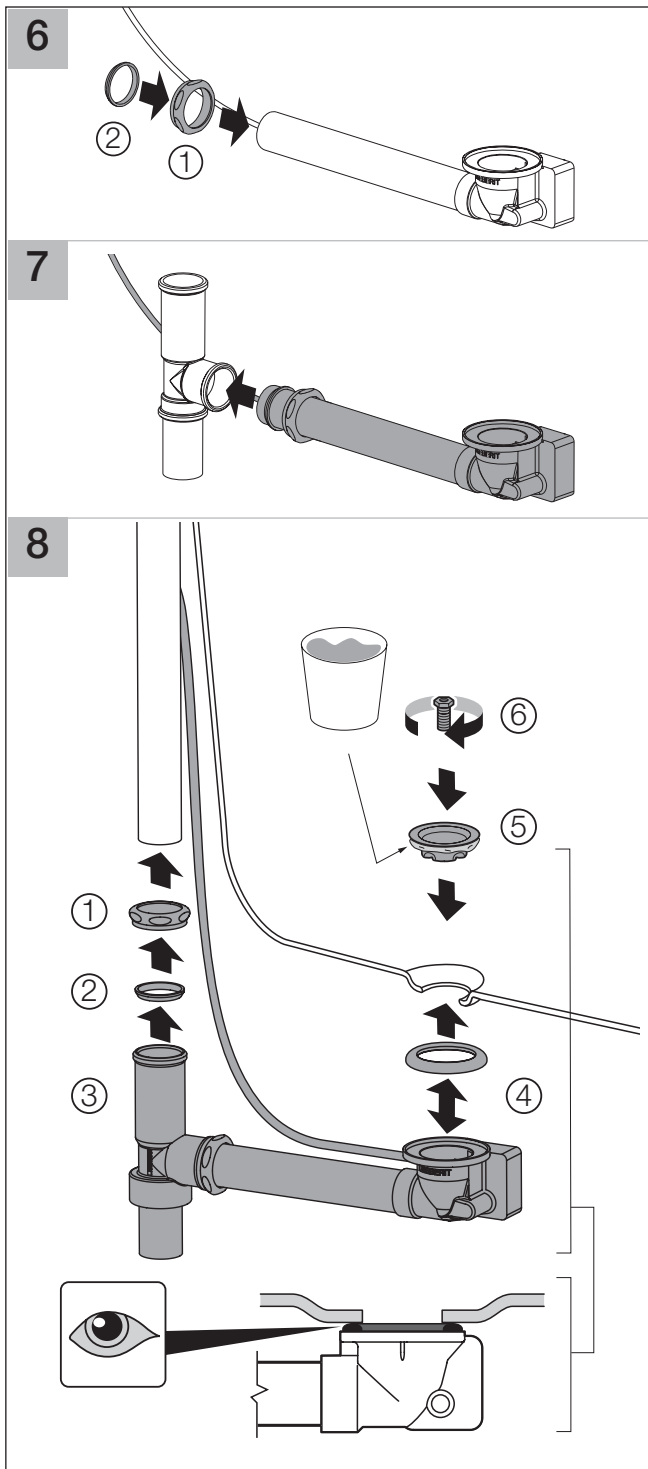

Installation

Installation

Instalación

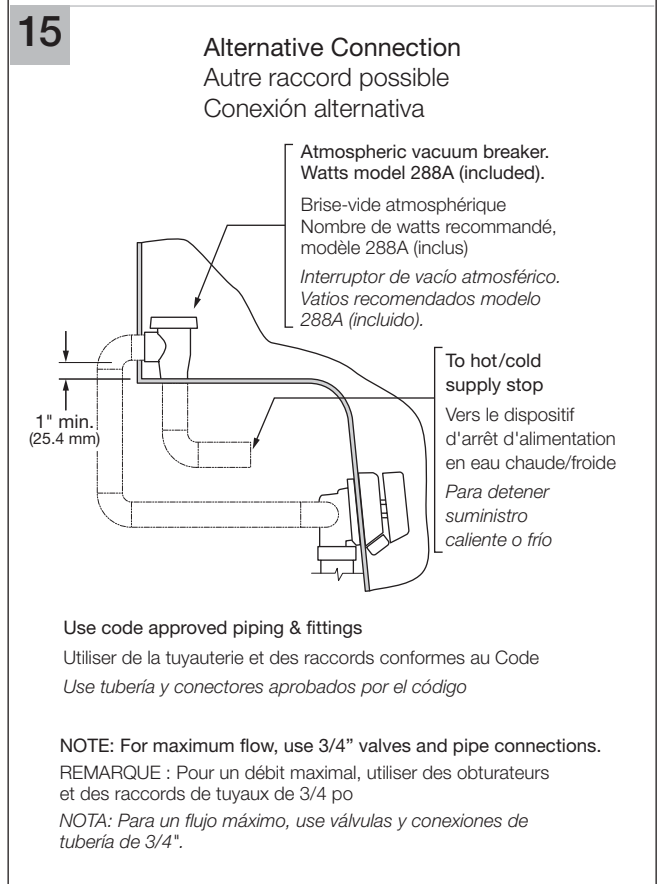
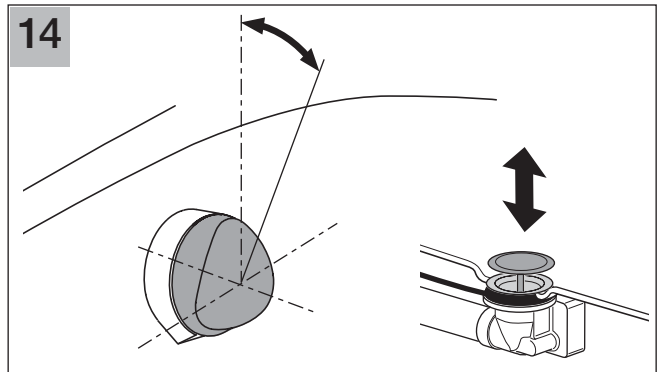
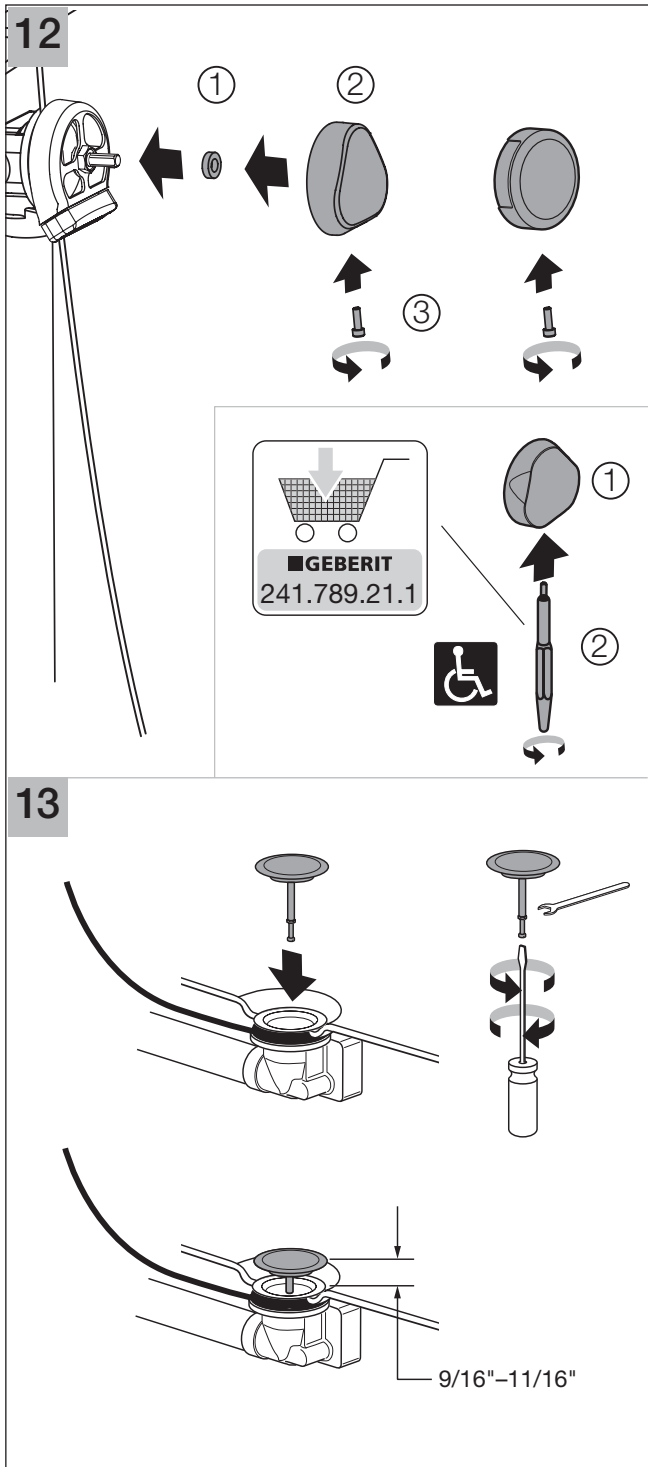

Geberit
2100 S. Clearwater Drive
Des Plaines, IL 60018
800/TECTRUE (800/832-8783)
www.geberit.us

GEB6038 0308